

Original operating guide
Assembly instructions

Twin screw pump FDS series



Архангельск (8182)63-90-72
Астана (7172)727-132
Астрахань (8512)99-46-04
Барнаул (3852)73-04-60
Белгород (4722)40-23-64
Брянск (4832)59-03-52
Владивосток (423)249-28-31
Волгоград (844)278-03-48
Вологда (8172)26-41-59
Воронеж (473)204-51-73
Екатеринбург (343)384-55-89
Иваново (4932)77-34-06

Ижевск (3412)26-03-58
Иркутск (395)279-98-46
Казань (843)206-01-48
Калининград (4012)72-03-81
Калуга (4842)92-23-67
Кемерово (3842)65-04-62
Киров (8332)68-02-04
Краснодар (861)203-40-90
Красноярск (391)204-63-61
Курск (4712)77-13-04
Липецк (4742)52-20-81
Киргизия (996)312-96-26-47

Магнитогорск (3519)55-03-13
Москва (495)268-04-70
Мурманск (8152)59-64-93
Набережные Челны (8552)20-53-41
Нижний Новгород (831)429-08-12
Новокузнецк (3843)20-46-81
Новосибирск (383)227-86-73
Омск (3812)21-46-40
Орел (4862)44-53-42
Оренбург (3532)37-68-04
Пенза (8412)22-31-16
Казахстан (772)734-952-31

Пермь (342)205-81-47
Ростов-на-Дону (863)308-18-15
Рязань (4912)46-61-64
Самара (846)206-03-16
Санкт-Петербург (812)309-46-40
Саратов (845)249-38-78
Севастополь (8692)22-31-93
Симферополь (3652)67-13-56
Смоленск (4812)29-41-54
Сочи (862)225-72-31
Ставрополь (8652)20-65-13
Таджикистан (992)427-82-92-69

Сургут (3462)77-98-35
Тверь (4822)63-31-35
Томск (3822)98-41-53
Тула (4872)74-02-29
Тюмень (3452)66-21-18
Ульяновск (8422)24-23-59
Уфа (347)229-48-12
Хабаровск (4212)92-98-04
Челябинск (351)202-03-61
Череповец (8202)49-02-64
Ярославль (4852)69-52-93

Table of contents

1	Introduction	5	6.3	Reduction of noise and vibrations	11
1.1	Foreword.....	5	6.4	Attach pump	11
1.2	Manufacturer	5	6.5	Align coupling	11
1.3	Delivery contents	5	6.6	Install pipelines	11
1.4	Pump without motor (optional)	5	6.7	Establish electrical connection	12
1.5	Documentation contents.....	5	6.8	Connect barrier or quench fluid (optional)..	12
1.6	Formatting conventions.....	5	6.9	Cleaning.....	13
2	Safety.....	6	7	Operation	13
2.1	Basic safety notices.....	6	7.1	Safety notices.....	13
2.2	Intended use	6	7.2	Commence operation.....	13
2.3	Foreseeable incorrect use.....	6	7.3	Observe operation	13
2.4	Pump-specific safety notices	6	7.4	End operation	14
2.5	Warning and notice signs	6	7.5	Remove the pump from operation.....	14
2.6	Noise emission	7	8	Cleaning during operation	14
2.7	Disposal	7	8.1	CIP method	14
3	Structure and function.....	7	8.2	SIP method	14
3.1	Basic structure	7	9	Faults	15
3.2	General remarks	8	9.1	Safety notices.....	15
3.3	Sizes	8	10	Maintenance	15
3.4	Add-ons	8	10.1	Safety notices.....	15
3.5	Type designation	8	10.2	Spare parts	15
4	Transport.....	9	10.3	Check the barrier and quench fluid (optional)	15
4.1	Safety notices	9	10.4	Check the oil level	15
4.2	Transport using forklift	9	10.5	Change oil	15
4.3	Transport by crane	9	10.6	Lubricate motor bearings.....	16
5	Storage	10	10.7	Replace shaft seal	16
5.1	Storage conditions for the pump.....	10	10.8	Dismantle pump head	16
5.2	Long-term warehousing	10	10.9	Mount pump head.....	17
5.3	Recommissioning	10	10.10	Replace shaft bearing	17
6	List	11	10.11	Check gap dimensions	17
6.1	Safety notices	11	11	Appendix 1	18
6.2	Installation site.....	11			

11.1	Technical specifications.....	18
11.2	Maintenance intervals.....	18
11.3	Fault table.....	19
11.5	EC Declaration of Conformity.....	21
11.6	EC Declaration of Incorporation	21
12	Appendix 2 – Assembly instructions (optional) for pump with bare shaft	22
12.1	Safety notice	22
12.2	Application.....	22
12.3	Nameplate.....	22
12.4	Transport without motor	22
12.5	Installation site.....	23
12.6	Mount pump	23

1 Introduction

1.1 Foreword

This operating guide describes all sizes, shapes and designs of the FDS twin screw pumps.

- ▶ Please refer to the nameplate on your pump and to the “*Order documents*” among the accompanying documents to see what shape, size, design and add-ons apply to your pump.

1.2 Manufacturer

FRISTAM Pumpen Schaumburg GmbH

Kurt-A.-Körber-Chaussee 55

21033 Hamburg

GERMANY

Tel.: +49 (0) 5721/ 98206 0

E-mail: info@fristam.de

1.3 Delivery contents

The delivery consists of:

- Pump with (gear) motor (= pump aggregate),
optional: Delivery without motor,
 - Pipe connection covers,
 - Documentation,
 - *Fristam* accessories if applicable,
 - optional: Assembly set.
- ▶ Check the delivery for completeness and any transport damages. In the event of any issues, inform *Fristam* immediately.

1.4 Pump without motor (optional)

The pump can be supplied without a motor as an option. In this case, read up through Chapter 3 “*Structure and function*” and then continue with Chapter 12 “*Appendix 2 – Assembly instructions (optional) for pump with bare shaft*”, Page 22.

1.5 Documentation contents

The documentation consists of:

- **this operating guide**
 - Appendix 1 with tables on maintenance, lubrication and tightening torques,
 - Appendix 2 with assembly instructions,

- **accompanying documents**

- order documents, (data sheet)
- supplier documentation (motor, coupling, etc.),
- documentation on Fristam accessories if applicable,
- certificates if applicable (material certificates, etc.),
- declaration of conformity or declaration of incorporation.

1.6 Formatting conventions

Lists are indicated by dashes:

- Part 1,
- Part 2.

Instructions that need to be worked through in a specific order are numbered consecutively:

1. Turn on unit.
2. Switch off unit.

Instructions that do not need to be worked through in a specific order use triangles as a convention:

- ▶ Action.
- ▶ Action.

1.6.1 Safety notices

⚠ DANGER

A safety notice with the signal word “Danger” alerts you to hazards to human beings that will inevitably result in death or serious injury.

⚠ WARNING

A safety notice with the signal word “Warning” alerts you to hazards to human beings that may result in death or serious injury.

⚠ CAUTION

A safety notice with the signal word “Caution” alerts you to hazards to human beings that may result in moderate or minor injury.

ATTENTION

A safety notice with the signal word “Attention” alerts you to the risk of property damage.

2 Safety

2.1 Basic safety notices

- ▶ Read this operating guide all the way through before using the pump and keep it available in the area where the pump is used.
- ▶ Observe the applicable national regulations in the operator country and in-house work and safety regulations.
- ▶ All works described here may only be carried out by qualified personnel exercising due care and caution.
- ▶ Risk of contamination: Observe statutory and in-house safety regulations when pumping hazardous pumped media.

2.2 Intended use

The standard version of the FDS twin screw pumps is designed for use in the food industry, in the pharmaceutical and biotechnology sectors, and for CIP process engineering.

FDS twin screw pumps are intended for pumped media having the maximum temperatures and pressures determined on the basis of the pump design and size. This information is listed on the order data sheet.

The pump's delivery rate is preset. The position of the suction and pressure port is indicated and is listed on the order data sheet. FDS twin screw pumps are able to generate negative pressure in the suction line.

Each pump is designed according to customer requirements. The sealing materials have been selected for the pumped medium in question.

The pump may only be operated under the conditions of use defined in the order. See "Order documents". If the operating conditions should differ, please contact *Fristam*.

2.3 Foreseeable incorrect use

The standard version of the FDS twin screw pumps may not be used in explosive atmospheres. Special Ex versions are available for such conditions.

Pumped media for which the pump is not designed may destroy the pump.

The presence of debris in the pumped medium may block and destroy the pump.

This operating guide describes standard *Fristam* pump aggregates. In the event of exceptions and the installation of extras, the operator is responsible for operation.

Conversions and modifications to the pump are only permitted after consulting with *Fristam*.

2.4 Pump-specific safety notices

Unacceptable pressure range

Personal injury and property damage caused by bursting and leaks in the pump.

- ▶ Comply with the pump's pressure range. See data sheet.

Unacceptable temperature range

Personal injury and property damage caused by bursting and leaks in the pump.

- ▶ Comply with the pump's temperature range. See order data sheet

Dry running

Property damage

- ▶ Dry running must be avoided, in principle. If the pump is equipped with a double-acting shaft seal, short-term dry running/"resting" is possible, provided that the seals are rinsed. If the pump is equipped with a single-acting shaft seal, even short-term dry running may cause damage.

Cold extinguishing water on heated pump

Property damage

- ▶ When extinguishing, do not focus the extinguishing stream directly on the pump.
- ▶ Let the pump cool off as slowly as possible.

Hot device surface

Skin burns from touching the pump.

- ▶ Check the temperature before touching the pump.
- ▶ Only touch the pump with heat-resistant protective gloves.

Noise emission when pump is running

Permanent hearing damage. The A-weighted sound pressure level of the pump may be higher than 80 dB (A).

- ▶ When in the vicinity of the running pump, always wear ear protection.
- ▶ Comply with local statutory regulations governing noise exposure.

2.5 Warning and notice signs

- ▶ Do not remove or alter the markings on the pump.
- ▶ Faithfully restore markings on the pump that have been damaged or lost immediately.

2.5.1 Hot surface



Fig. 1 Safety marking: "Hot surface"

This marking indicates that parts may become hot as a result of pump operation, or that hot pumped fluids may be pumped at this point. Check the temperature before touching the pump. The pump must only be touched while wearing suitable protective gloves.

2.5.2 Nameplate

		FDS 3 - 2		
Serial Number	123456789	Point I	Point II	CIP
Job-No.	123456789	Medium		
Year	2016	Q [m³/h]		
Pump Weight [kg]	110	T [°C]		
Pump	II 2G ck(b1) IIB T3	η [mPas]		
Aggregate	II 2G IIB T3	pi [barg]		
TÜV NORD CERT-Nr.	35182047	pd [barg]		
		P [kW]		
		n [1/min]		
 Fristam Pumpen Schaumburg GmbH Kurt-A.-Körber-Chaussee 55 D-21033 Hamburg		 Service		

Fig. 2 Nameplate

2.6 Noise emission

CAUTION

Noise emission when pump is running

Permanent hearing damage

- ▶ Comply with local statutory regulations governing noise exposure.
- ▶ When using pumps for which a sound pressure level of greater than 80 dB (A) is indicated, wear hearing protection.

2.7 Disposal

2.7.1 Disposal of transport packaging

- ▶ Take transport packaging to a recycling centre.

2.7.2 Disposal of lubricant

- ▶ Grease and greasy objects are to be disposed of in an environmentally friendly manner in accordance with applicable regulations.

2.7.3 Disposal of lubricating oil

- ▶ Oil and oily objects are to be disposed of in an environmentally friendly manner in accordance with applicable regulations.

2.7.4 Disposal of pump

1. Dispose of hazardous and toxic residues in an environmentally friendly manner and in accordance with applicable regulations.
2. Clean the pump carefully.
3. Disassemble pump into the individual components.
4. Dispose of pump parts in an environmentally friendly manner in accordance with applicable regulations.

2.7.5 Disposal of electrical and electronic waste

- ▶ Dispose of electrical and electronic waste in accordance with the applicable guidelines.

3 Structure and function

3.1 Basic structure

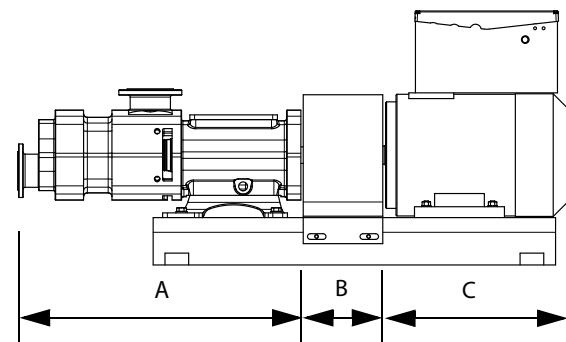

Fig. 3 Basic structure of the FDS pump aggregate

- | | |
|---|----------------------------|
| A | Pump with synchromesh gear |
| B | Coupling |
| C | Motor/gear motor |

3.1.1 Pump with synchromesh gear (A)

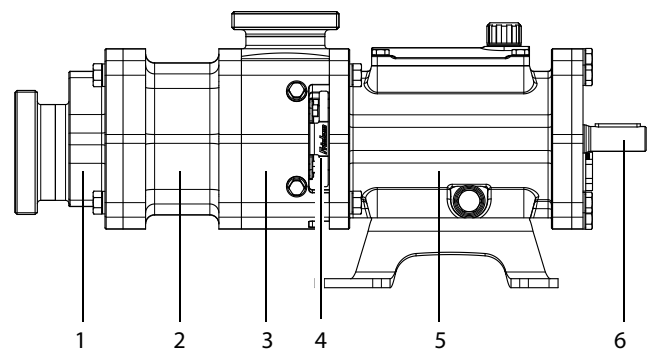

Fig. 4 Basic structure of an FDS positive displacement pump

- | | |
|---|--------------|
| 1 | Pump cover |
| 2 | Pump housing |

3	Intermediate flange
4	Leakage chamber of the shaft seal
5	Bearing bracket
6	Drive shaft

3.1.2 Coupling (B)

The coupling connects the shaft from the motor to the drive shaft (6) of the pump. The coupling transfers the drive torque of the (gear) motor to the pump.

3.1.3 Motor/gear motor (C)

The drive is an electric motor with fixed or variable speed. It is bolted to the base frame or foundation.

3.2 General remarks

The following versions are available as an option for all configurations:

- single or double shaft seal

One of two seal types can be selected: Single shaft seal or double shaft seal.

In the double shaft seal version, there are four additional ports for the barrier fluid on the intermediate flange. These ports are not depicted in the illustrations in this operating guide; see Chapter 6.8.1 “Connect pipelines”, Page 12.

- horizontal or vertical pump connection,
- heating jacket

The pump can be equipped with a heating jacket on the pump housing.

3.3 Sizes

FDS series
FDS 1
FDS 2
FDS 3
FDS 4
FDS 5

Table 1 Sizes

3.4 Add-ons

FDS twin screw pumps may be equipped with the following add-ons, among others:

- Lining

Stainless steel lining for the motor. The lining is attached to the base frame,

- Domed feet

Domed feet on which to install the pump. Domed feet are mounted on the base frame of the pump.

Additional add-ons are possible. Please contact *Fristam* if you have any questions.

3.5 Type designation

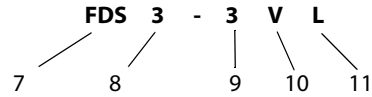

Fig. 5 Type designation example

7	Pump type
8	Size
9	Displacement device
10	Additional symbol 1
11	Additional symbol 2

(7) Type of pump

FDS Twin screw pump, self-priming

(8) Size

X Number of size

(9) Displacement device

X Number of the installed displacement device

(10) Additional symbol 1

V vertical

S lateral

– no symbol means standard

(11) Additional symbol 2

L extended

Note: If your pump is delivered without a motor (optional) begin by reading Chapter 12 “Appendix 2 – Assembly instructions (optional) for pump with bare shaft”, Page 22.

4 Transport

The pump may only be transported by trained personnel.

The pump aggregate may be transported by forklift or by crane.

4.1 Safety notices

Falling or unsecured components

Severe bruises.

- ▶ Always wear safety shoes during all transport work.

Incorrect transport position of the pump

Leakage of corrosive, toxic or contaminating fluids. Personal injury and property damage caused by contamination.

- ▶ Always transport pump in the installation position.

Open, unsealed pipe connections

Property damage caused by contaminants, impacts or moisture in the pump.

- ▶ Do not remove the pipe connection covers until immediately prior to connecting to the pipes.

4.2 Transport using forklift

⚠ WARNING

Unsecured components

Serious injuries, bruising of limbs, property damage.

- ▶ Secure the pump against toppling prior to transport. Secure onto the pallet using transport straps or bolt the pump onto the pallet.

Preparation

- ▶ Check whether the pump is adequately secured on the pallet. For instance using straps, see Fig. 6 "Transport by forklift", Page 9.
- ▶ Take into account the weight of the pump when selecting the means of transport. For information on the weight of the pump see the pump nameplate and refer to "Order documents" in the accompanying documents.

Procedure

1. Pick up the pallet using the forklift.
2. Slowly and smoothly transport the pallet to the destination and deposit there.

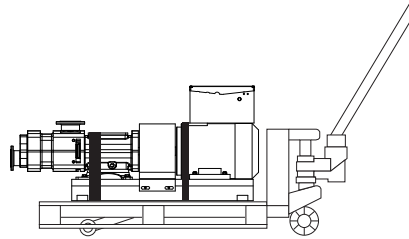

Fig. 6 Transport by forklift

4.3 Transport by crane

⚠ WARNING

Falling parts

Death by crushing, serious bruising of limbs, property damage.

- ▶ Use only appropriate means of transport and lifting tackle. For information on the weight of the pump see the pump nameplate and refer to "Order documents" in the accompanying documents.
- ▶ Do not transport the pump aggregate by the eyebolts on the motor or on the pump, as these eyebolts are not designed to bear the full weight of the pump aggregate.
- ▶ Do not leave the pump in the raised position longer than necessary.
- ▶ Make sure that there is no one in the area below the pump.

⚠ WARNING

Vibrating parts

Bruising and serious injury.

- ▶ Approach the pump smoothly with the crane and come to a smooth stop.
- ▶ Make sure that there is no one in the danger zone of the pump.

Aids

Lifting tackle: tested round slings in accordance with DIN EN1492-1 and 1492-2.

Preparation

- ▶ Remove transport safety devices.

Procedure

1. **Warning:** Damage to and tearing of the round sling. Death by crushing, serious bruising, property damage.
 - ▶ Do not let the round sling come into contact with sharp corners and edges.

Place the round sling around the gear motor, see Fig. 7 "Transport with round sling", Page 10.

2. Put the other end of the round sling around the pump housing, see Fig. 7 "Transport with round sling", Page 10.
3. Double shaft seal:

Attention: The round sling presses against the barrier water tubes. Damage to double shaft seal.

- ▶ Circumvent the barrier water tubes with the round sling.
- 4. Walk both slings to the crane hook, twist and place on the hook in such a way that the strap cannot slip off the crane hook.
- 5. Arrange the centre of gravity to make sure that the pump is lifted in the horizontal position.
- 6. Lift the pump.

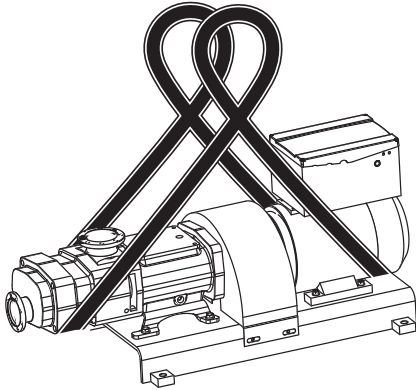

Fig. 7 Transport with round sling

5 Storage

5.1 Storage conditions for the pump

Store the pump as follows:

- dry, at low humidity,
- protected against frost and heat, preferably at 20°C to 25°C,
- ventilated,
- dust-free.
- ▶ All of the pump's moving parts must be turned every three months.

5.2 Long-term warehousing

The following must be kept in mind if the pump is being stored for more than six months:

- ▶ before placing the pump in storage, completely disassemble the shaft seals and store separately.
In this regard please refer to *Chapter 5.2.1 "Storage of elastomers", Page 10.*
- ▶ Fill gearbox with oil up to the upper edge of the gear wheel.

5.2.1 Storage of elastomers

Store elastomers as follows:

- storage temperature between +5°C and +20°C,
- relative humidity below 70%,
- no direct sunlight,
- deformation-free storage.

5.3 Recommissioning

- ▶ After warehousing, the seals, bearings and oil level must be checked before recommissioning.

6 List

6.1 Safety notices

Falling or unsecured components

Severe bruises.

- ▶ Always wear safety shoes during all installation work.

Incomplete, unstable mounting

Severe bruises, damage to property.

- ▶ Tighten screws with the specified tightening torque, see *Chapter 11.1.1 "Tightening torques", Page 18*.
- ▶ Use a torque wrench or impact wrench with adjustable torque.

Vibrations during domed foot installation

Damage to plant and pump.

- ▶ Use domed foot plate.

6.2 Installation site

The installation site for pumps with standard equipment must satisfy the following conditions:

- Non-explosive atmosphere.
- Dust-free environment.
- Ambient temperature: -20°C to $+40^{\circ}\text{C}$.
- Values for the humidity and salinity of ambient air are indicated in the motor supplier documentation in the accompanying documents.
- A foundation sufficiently dimensioned for the weight of the pump.
- Horizontal and flat installation surface. Strength of installation surface is sufficient for the mass of the pump.
- Refer to the motor supplier documentation for installation clearances.
- Adequate space for maintenance.
- Adequate ventilation for motor cooling.

6.3 Reduction of noise and vibrations

6.3.1 Primary measures

- Operate the pump in the optimal working range.
 - ▶ Operate the pump without cavitation (see *Chapter 6.6 "Install pipelines", Page 11*).
- Isolate suction and pressure line from vibrations.
 - ▶ Support the lines.
 - ▶ Align the lines.
 - ▶ Insert elements for vibration damping.

6.3.2 Secondary measures

- ▶ Implement structural measures such as:
 - Sound insulation cover,
 - Enclosure.

6.4 Attach pump

6.4.1 Pump with base frame

- ▶ Screw pump onto the foundation through the base frame.

6.4.2 Pump with base frame on domed feet (optional)

- ▶ Install the pump on the domed feet and align.

6.4.3 Chassis (optional)

1. Set up the pump at the installation site. Use the locks on the casters (if present) or fix the chassis using chocks.
2. Ground the chassis in order to dissipate electrostatic charges.
3. Lay the hose in such a way that it cannot be damaged.

6.5 Align coupling

1. Check centre offset and angular offset of the shafts.

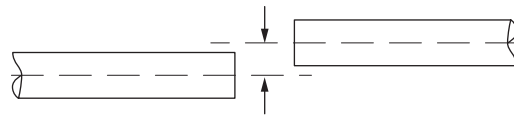

Fig. 8 Centre offset

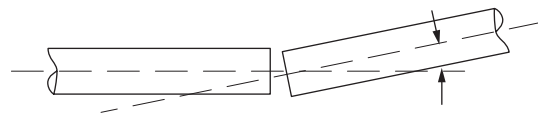

Fig. 9 Angular offset

2. Re-align or shim the shafts as needed. See the enclosed coupling supplier documentation for more precise information.

6.6 Install pipelines

Lay and connect pipelines as follows:

- ▶ Keep pipeline resistance as low as possible: Avoid the unnecessary installation of valves, bends and abrupt transitions.

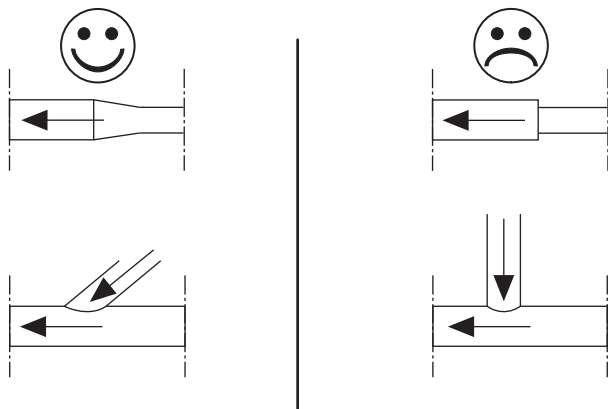

Fig. 10 Pipeline crossings

- ▶ Design the pipeline cross-section in such a way that no unnecessary pressure losses occur, or cavitation in the suction or inlet area.
- ▶ Marking: if possible, fit shut-off valves in the suction and pressure line. Pay attention to correct connection (suction side and pressure side). The housing is provided with corresponding markings.
- ▶ Design the suction lines to be as short as possible.
- ▶ Lay the suction lines horizontally or continuously sloping in the direction of the pump aggregate. Make sure there are no air cushions or sinks in the pipelines.

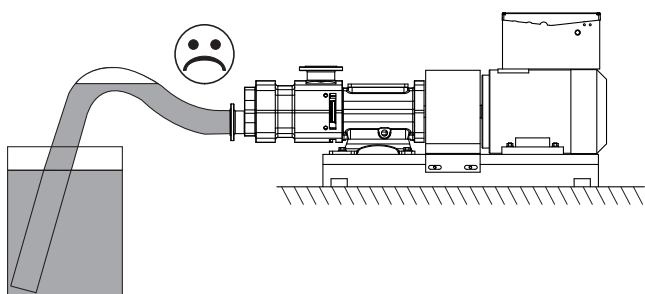

Fig. 11 Air cushions in the pipeline

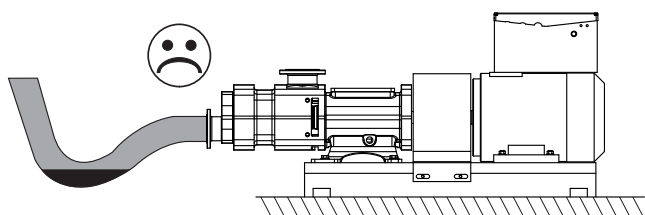

Fig. 12 Sinks in the pipeline

- ▶ Design pipe connections as a function of: pressure, temperature and nature of the pumped medium.
- ▶ Lay and connect the pipelines in such a way that no warping occurs on the pump.
- ▶ Affix pipelines to ceilings, walls or ground using pipe clamps.
- ▶ Align the pipelines flush with the pump connections using an angle.

6.7 Establish electrical connection

⚠ WARNING

Electrostatic charge

Electric shock.

- ▶ Ground pipelines and the pump so that electrostatic charges can be dissipated.

The electrical connection may only be carried out by a qualified electrician.

Procedure

1. Observe the connection values on the motor nameplate. The specified voltage must not be exceeded.
2. Only connect the motor to fused electrical circuits in order to prevent excessive current consumption.
3. Connect the motor in accordance with the wiring diagram in the motor terminal box.
4. Protect cable penetrations against the ingress of moisture.
5. Turn the motor on for 2 to 3 seconds. During this time, check the direction of rotation of the motor fan impeller.
6. If the direction of rotation is wrong, reverse the polarity as needed.

6.8 Connect barrier or quench fluid (optional)

For versions with a double shaft seal, the seal chamber of the shaft seal must be rinsed with barrier fluid or quench fluid.

- ▶ Use a suitable medium as barrier fluid or quench fluid.
- ▶ See Appendix - Data sheet

6.8.1 Connect pipelines

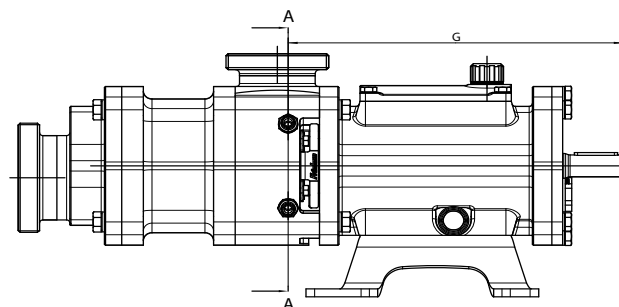

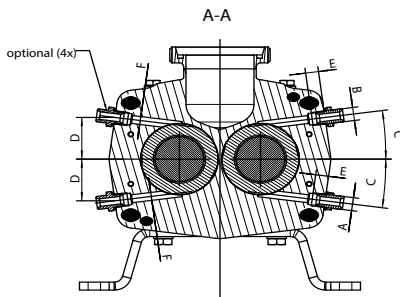

	Inlet A	Outlet B	C	D	E	F	G
FDS 1							
FDS 2	G¼" (m/f)	G¼" (m/f)	7.5°	42	12	Ø8	310
FDS 3	G¼" (m/f)	G¼" (m/f)	7.5°	50.5	12	Ø10	375.5
FDS 4							

Table 2

1. Fit the feed line **below** the shaft seal.
2. Fit the drain line **above** the shaft seal.

6.9 Cleaning

Only use cleaning agents that meet the technical hygiene standards for the respective pumped medium.

1. Before closing the pump, make sure that there are no foreign substances inside the pump and pipelines.
2. Close the pump.
3. Connect the pipelines.
4. Prior to first use, clean the pump and pipeline system completely.

7 Operation

7.1 Safety notices

Closed valve in the pressure line

Serious personal injury and property damage caused by a bursting of the system due to very high pressure build-up.

- ▶ Both before switching on and during operation, make sure that all of the pressure line's valves are open.
- ▶ Provide a bypass or other approved safety devices for pressure peaks, as this is a positive displacement pump.

Closed valve in the suction line

Damage to the shaft seal due to dry running of the pump.

- ▶ Both before switching on and during operation, make sure that all of the suction line's valves are open.

No pumped medium inside the pump

Dry running of the pump. Damage to the shaft seal.

- ▶ For single shaft seal pumps, make sure that there is always pumped medium inside the pump both prior to and during operation.

7.2 Commence operation

ATTENTION

Double shaft seal: Loss of barrier fluid

Damage to the shaft seal.

- ▶ During operation, make sure that:
 - Barrier fluid with sufficient pressure is flowing through the double shaft seal (see information on the enclosed "Data sheet"),
 - The temperature of the barrier fluid is maintained at $T < 70^{\circ}\text{C}$.

1. Open the valve in the suction line.
2. Open the valve in the pressure line.
3. Fill the pump and suction line with pumped medium to the upper edge of the pump. Allow any air pockets that may be present to escape.
4. Only for pumps with barrier or quench fluid:
 - Verify the necessary barrier pressure. For maximum barrier pressure, please refer to the "Data sheet" in the enclosed documents.
5. Switch on the motor.

7.3 Observe operation

While the pump is running, observe the following safety notices:

ATTENTION

Debris in the pumped medium

Blocking of displacement device and shearing of the shaft.

- ▶ Eliminate debris in the pumped medium.
 - Provide a current limiting device on the gear motor.

ATTENTION

Sudden closing of the valves in the pressure line

Damage to the system possible through excess pressure.

- ▶ During operation do not close the valve in the pressure line suddenly or for an extended period of time.

ATTENTION

Sudden cooling of the pump

Stress cracks in the pump.

- Do not abruptly cool the pump.

ATTENTION

Cavitation and dry running of the pump

Damage to the shaft seal.

- During operation, make sure that the suction side valves are open.

7.4 End operation

1. Switch off the motor.
2. Close the valve in the suction line in order to prevent dry running of the pump.
3. Close valve in the pressure line.

7.5 Remove the pump from operation

1. Switch off the motor.
2. Close the valve in the suction line.
3. Close valve in the pressure line.
4. Disconnect the pump from the power source.
5. Drain the pump.
6. Clean the pump as described in *Chapter 6.9 "Cleaning", Page 13.*
7. Dry the pump.
8. Protect the interior of the pump against moisture, for instance using silica gel.
9. Fit caps over the pipe connections in order to prevent dirt and debris from entering.
10. For additional steps please refer to *Chapter 5 "Storage", Page 10.*

8 Cleaning during operation

8.1 CIP method

The FDS twin screw pumps are suitable for the CIP (Cleaning In Place) method. Observe the following indicative values during the CIP process:

Example cleaning process

1. Pre-rinse with water.
2. Caustic flushing with sodium hydroxide (NaOH, see *Table 3 "CIP cleaning", Page 14.*)
3. Perform an intermediate water rinse.
4. Acid flushing with nitric acid (HNO₃, see *Table 3 "CIP cleaning", Page 14.*)
5. Final rinse with water.

The differential pressure of the pump should be 2 to 3 bar, so that adequate flow rates are achieved in the pump.

Medium	Process temperature [°C]
NaOH (approx. 1% to 2%)	80 to 85
HNO ₃ (approx. 1%)	60 to 65

Table 3 CIP cleaning

Please contact *Fristam* if the values should deviate.

8.2 SIP method

ATTENTION

Dry running of the pump with steam

Damage to the shaft seal.

- ▶ When steam is flowing through the pipes, make sure that the pump is switched off.
- ▶ Slow rotation with the shaft is possible if the pump has a double shaft seal (<300 1/min)

FDS twin screw pumps are only suitable for the SIP (Sterilisation In Place) method in consultation with *Fristam*.

Suitability depends on the choice of elastomers.

The maximum process temperature is 145°C.

Temperatures in ATEX may differ; please refer to the ATEX operating instructions "Temperature configuration limit".

9 Faults

Please refer to *Chapter 11.3 "Fault table", Page 19* with regard to faults, possible causes and remedies.

9.1 Safety notices

Hot device surface

Skin burns from touching the pump. The pump may become very hot when conveying hot pumped media.

- ▶ Before undertaking work on pump, allow the pump to cool off completely.
- ▶ Check the temperature before touching.
- ▶ Only touch the pump with heat-resistant protective gloves.

10 Maintenance

Please refer to *Chapter 11.2 "Maintenance intervals", Page 18* regarding maintenance intervals.

10.1 Safety notices

Rotating parts

Personal injury and property damage.

- ▶ Before working on the pump, **always** switch off the pump's motor and secure against reactivation.

Falling or unsecured components

Severe bruises.

- ▶ Always wear safety shoes during all maintenance work.

Uncontrolled escape of liquids

Personal injury and property damage caused by chemical burns, poisoning or contamination.

Before performing maintenance and cleaning work on the pump:

- ▶ Close the suction and discharge valves upstream and downstream of the pump.
- ▶ Double shaft seal: Shut the barrier or quench fluid line.
- ▶ Completely drain the pump housing before opening the pump.

Sudden cooling of the pump

Stress cracks in the pump.

- ▶ Do not abruptly cool the pump.

Using hard screwdriving tools

Scratching of milled surfaces.

- ▶ Use a copper insert for socket wrenches on milled surfaces.

10.2 Spare parts

Using spare parts not approved by *Fristam* may result in serious personal injury and property damage. Please contact *Fristam* for any questions regarding approved spare parts.

Fristam maintains a record of all pumps delivered. The following information is required when ordering spare parts:

1. Serial number of the pump: refer to the nameplate or the rim on the pump.
2. For designations of spare parts and materials, please refer to "Order documents" in the accompanying documents.

10.3 Check the barrier and quench fluid (optional)

For pumps that have been equipped for "barrier fluid" or "quench fluid", the quench fluid pressure must be checked. For maintenance intervals refer to *Table 5 on page 18*.

- ▶ Check the barrier fluid pressure and compare to the specified value.

For the specified value please refer to the "Data sheet" in the "Order documents". The "Order documents" are enclosed with this operating guide.

A hot pumped medium and operation of the pump cause the barrier fluid to become heated.

- ▶ Make sure that the temperature of the barrier fluid is maintained at $T < 70^{\circ}\text{C}$ during operation.

10.4 Check the oil level

This check is performed via an oil level gauge (14) located on the back of the closing cap.

For maintenance intervals refer to *Table 5 on page 18*.

10.5 Change oil

Change the oil regularly on the FDS twin screw pumps. For maintenance intervals refer to *Table 5 on page 18*.

Maintenance intervals

In general, change the oil once each year or every 4000 operating hours.

In extreme operating conditions, such as high humidity, an aggressive environment, high temperature fluctuations, etc., we recommend changing the oil every 2000 operating hours.

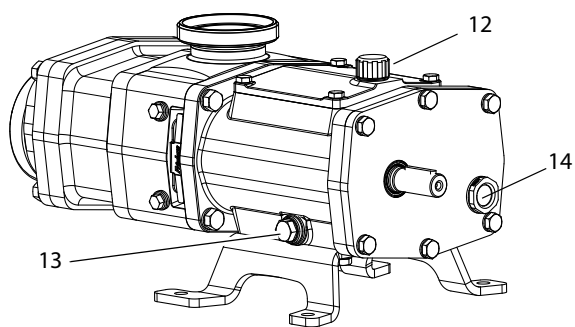

Fig. 13 Oil level and oil change

12	Bleed screw
13	Locking screw
14	Oil level gauge

Procedure

1. Switch on the engine and let it run until the normal operating temperature is reached.
2. Switch off the motor and secure it against reactivation.
3. Place an appropriately sized oil pan below the locking screw (13).
4. **Caution!** Risk of burns from hot oil.
 - ▶ Wear heat- and oil-resistant protective gloves.
 Loosen the bleed screw (12).
5. Loosen and remove the locking screw (13).
6. Drain the oil completely and dispose of it in accordance with local regulations.
7. Clean the bleed screw and seals.
8. Fit the locking screw and bleed screw with the appropriate seals.
9. Add new oil, in so doing checking the oil level using the oil level gauge (14).

10.6 Lubricate motor bearings

- ▶ Lubricate the motor bearings in accordance with the gear motor manufacturer’s specifications. Please refer to “Supplier documentation” in the accompanying documents.

10.7 Replace shaft seal

Replace the shaft seal if:

- Pumped medium, barrier fluid or quench fluid is leaking out of the pump on the atmospheric side,
- Barrier fluid or quenching fluid is leaking into the pumped medium.

Procedure at a glance

1. Dismantle the pump housing, see Chapter 10.8 “Dismantle pump head”, Page 16.

2. Replace shaft seal, see Chapter 10.9.2 “Installation of the shaft seal”, Page 17.
 - ▶ Pre-mount the pump housing.
 - ▶ Install the shaft seal.
3. Mount the pump housing.
4. Mount the displacement device.
5. Close the pump cover.

The exact procedure is described in the following chapters.

10.8 Dismantle pump head

10.8.1 Dismantle pump housing and feed screws

Preparation

1. Before dismantling, refer to the enclosed “data sheet” to determine which type of shaft seal the pump has.
2. Switch off the motor and secure it against reactivation.
3. Close valve in the pressure line.
4. Close the valve in the suction line.
5. Double shaft seal: Shut the barrier or quench fluid line.
6. Drain the pump completely.
7. Loosen the suction and pressure connections.

Procedure

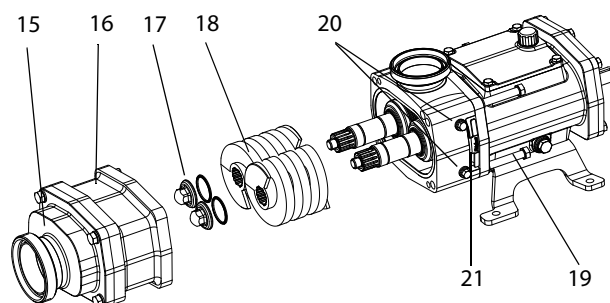

Fig. 14 Dismantle the pump housing with cover and the feed screws

1. Loosen the screws (19) for the pump housing attachment.
2. Remove the pump housing (16) with cover (15) .
3. **Warning:** Rotating machine parts. Severe bruises inflicted on hand.
 - ▶ Block the feed screws (18) with an aluminium or plastic wedge.
 Screw off the feed screw attachment (17) with the associated sealing rings (clockwise thread).
4. Remove the feed screws (18) from the drive shaft and the driven shaft.

10.8.2 Dismantle the shaft seal

The pump may be supplied with a single or double-acting shaft seal (see data sheet).

1. Loosen the fastening screws (20) for the fixing plate (21).
2. Pull out the fixing plates.
3. Remove rotating units from the shafts.
4. Pull stationary units out of the intermediate flange.

10.9 Mount pump head

Pump assembly is dependent on the specific size and shape of the pump, and on the given shaft seal. The type of shaft seal provided is indicated on the "Data sheet".

ATTENTION

Wrong elastomers

Pump leakage.

- ▶ Make sure that the elastomers are suited to the nature of the pumped medium. Refer to the "Data sheet".

Preparation

- ▶ Clean all pump parts. Check for damage and accuracy of fit.
- ▶ Rework or replace pump parts as needed.
- ▶ Reassemble carefully under clean conditions. The seals can easily be damaged.
- ▶ In order to reduce friction, wet the secondary seals and sliding surfaces with water, alcohol or silicone grease.
- ▶ Clean the sealing surfaces of the mechanical seals with grease-loosening cleaning agent, for instance "OKS 2610 Universalreiniger". After that, do not allow the sealing surfaces to come into contact with oil or grease, and do not touch them with your fingers.

Tip: The bonding compound "Euro Lock A64.80" is suitable for gluing bearings and bushings in place.

Tip: The bonding compound "Euro Lock A24.10" is suitable for gluing grub screws in place.

10.9.1 Observe markings

The feed screws must not be mixed up under any circumstances. They are assigned to the drive shaft or driven shaft, and each have been marked with punches.

- ▶ Note the markings before installing feed screws:
 - one frontal punch for the drive shaft,
 - two frontal punches for driven shaft.

10.9.2 Installation of the shaft seal

1. Reinsert the shaft seal into the intermediate flange in accordance with the sectional drawing (anti-torsion groove exactly lateral).
2. Reinsert the fixing plates (let them snap into place) and fix using the screws.
3. Slide rotating parts onto the shafts.

10.9.3 Mount the pump housing and feed screws

1. **Attention:** Feed screws are assigned either to the drive shaft or the driven shaft. See Chapter 10.9.1 "Observe markings", Page 17.
2. Push feed screws onto the shafts.
3. **Warning:** Rotating machine parts. Severe bruises inflicted on hand.
 - ▶ Block the feed screws with an aluminium or plastic wedge.
4. Tighten the feed screw using the specified tightening torque. Please refer to Table 4 "Tightening torques for feed screw", Page 17.

Size	Thread	Tightening torque [Nm] ± 15%
FDS1	M12	60
FDS2	M16	120
FDS3	M20	160
FDS4	M24	200
FDS5	M24	240

Table 4 Tightening torques for feed screw

5. Place the housing with cover onto the pump and tighten the screws.

10.9.4 Close the pump

1. Provide the pump cover with an O-seal.
2. Slide the pump cover onto the pump housing.
3. Screw the pump cover onto the pump housing with nuts and washers.

10.10 Replace shaft bearing

- ▶ Contact Fristam.

10.11 Check gap dimensions

Contact Fristam.

11 Appendix 1

11.1 Technical specifications

11.1.1 Tightening torques

Tightening torque for screws and nuts $\pm 15\%$

Material: Steel, grade 8.8

Thread	M6	M8	M10	M12	M16	M20	M24
Tightening torque [Nm]	7	18	35	60	148	254	-

Material: Steel, grade 10.9

Thread	M6	M8	M10	M12	M16	M20	M24
Tightening torque [Nm]	11	26	51	89	218	361	-

Material: Stainless steel, class 70

Thread	M6	M8	M10	M12	M16	M20	M24
Tightening torque [Nm]	7	18	36	63	143	262	424

Material: Stainless steel, grade 80

Thread	M6	M8	M10	M12	M16	M20	M24
Tightening torque [Nm]	10	24	48	84	191	351	568

11.2 Maintenance intervals

Interval	Shape	Maintenance activity	Chapter
Daily	All	Check the oil level	See Chapter 10.4 "Check the oil level", Page 15
Daily	"Barrier and quench fluid" option	Check barrier or quench fluid	See Chapter 10.3 "Check the barrier and quench fluid (optional)", Page 15
2000 h	All, in extreme operating conditions	Oil change	See Chapter 10.5 "Change oil", Page 15
4000 h	All, in normal conditions	Oil change	See Chapter 10.5 "Change oil", Page 15
As needed	All	Replace shaft seal	See Chapter 10.7 "Replace shaft seal", Page 16
As needed	All	Replace coupling/coupling spider	
As needed	All	Change engine	
According to manufacturer instructions	All	Lubricate the motor bearing; for further motor maintenance intervals refer to the motor supplier documentation.	See Chapter 10.6 "Lubricate motor bearings", Page 16

Table 5 Maintenance intervals

11.3 Fault table

Issue	Possible cause	Remedy
Pump does not pump or pumps irregularly	Pump interior not filled completely with fluid; discharge valve closed	Fill the pump interior with fluid; Open the discharge valve
	Blocked or clogged suction line	Open or clean the suction line
	Pump with geodetic suction head ¹ : Liquid drops during standstill and housing runs idle	Install foot valve in the suction line
	Suction line leaky; seal on the pump cover is leaky and draws air	Seal the suction line; replace the cover seal
	Air pocket in the suction line	Lay the suction line with continuously rising elevation and with few diversions
	Pump is blocked; debris in pump	Clean the inside of the pump; visual inspection; consult <i>Fristam</i>
	Viscosity of the pumped medium is too high; not able to flow, too viscous	Consult <i>Fristam</i>
	Coupling penetrated due to previous overloading	Consult <i>Fristam</i>
Delivery rate too great	Oversized pump	Consult <i>Fristam</i>
	Speed too high	Decrease speed
Delivery rate too low, pump head too low	Pump selected is too small; motor speed too low due to incorrect frequency	Consult <i>Fristam</i> ; Connect in accordance with the motor nameplate
	Suction line leaky and draws air	Fix leaks
	Viscosity of the pumped medium is too high (too viscous);	possible conversion to integrate a heating system; consult <i>Fristam</i>
	Wear on the displacement device; gap dimension too large	Repair/replacement
	Incorrect direction of rotation	Carry out pipe and electrical connections properly
Metallic noise	Debris inside the pump	Dismantle, assess, repair as needed
	Mechanical start-up of the feed screws; Feed screw nut is loose	Dismantle, rework, Correct slackness setting, tighten with tightening torque, replace
	Excessive wear on bearings and gears wheels due to overloading or insufficient lubrication	Dismantle, assess, repair Regular maintenance; lubricant service
	Speed too high	Use motor with frequency converter; Consult <i>Fristam</i>
	Pump running dry; shaft seal running dry	Supply pumped medium immediately; supply barrier water immediately
Flow noise	Operation in load range	Adjust operating point of the configuration
	Flow losses in the suction line too great	Increase the size of nominal widths, Rule out throttling
	Cavitation	Check condition for NPSH calculation; see <i>Chapter 6.6 "Install pipelines", Page 11</i> ; Consult <i>Fristam</i>
Vibrations	Dead weight and hydraulic forces of the pipelines are putting strain on the pump.	Support the pipelines in such a way that the pump is not subjected to strain; integrate vibration dampers as needed; make sure pressure shocks do not reach the pump
	Incorrect alignment of coupling	Align the coupling in accordance with the coupling manufacturer's specifications
Excessive heating of the pump shaft bearing and drive gear	Bearing damage	Dismantle, replace bearing
	Lack of lubricant	Replace lubricant; Regular maintenance, see <i>Table 5 on page 18</i> , or replenish
	Incorrect alignment of coupling	Align the coupling in accordance with the coupling manufacturer's specifications

Table 6 Fault table

Issue	Possible cause	Remedy
Motor current consumption too high	Resistance in the pressure line too high; (delivery rate too low)	Increase nominal width of the pressure line; reduce
	Viscosity and/or density of the pumped medium too high	Consult <i>Fristam</i>
	Massive damage to the pump shaft bearing or to the gear motor	Dismantle and assess; Consult <i>Fristam</i>
Leak on the shaft seal	Mechanical damage or wear on the shaft seal	Replace mechanical seal and radial shaft seal, including all secondary seals; consider material changeover; consult <i>Fristam</i>
	Dry running of the shaft seal; suction head too high; pumped medium temperature too high	Reduce the geodetic suction head ¹ ; use a double shaft seal; consult <i>Fristam</i>
	Barrier or rinse water pressure too high	Adjust using throttle valve and pressure gauge
	Materials of the shaft seal not chemically resistant to the pumped medium; media temperature too high	Consult <i>Fristam</i> ; Change over to cooling or double shaft seal
	Barrier or rinse water pressure too low; barrier water tubes are clogged; shaft seal is encrusted or damaged;	Adjust barrier water inflow and outflow; clean the barrier water tubes; replace the shaft seal
	Barrier water contaminated or too hot	Use drinking quality water at a maximum of 70°C

Table 6 Fault table

¹The "geodetic head" is the vertical distance between the surface of the suction-side fluid level and the centre of the pump-pipe connections.

11.4 Numerical code

The numerical code refers to the enclosed "sectional drawings". The part numbers correspond to DIN 24250.

Item	Designation
101	Pump housing
113	Intermediate flange
160	Cover
161	Gear housing cover
182	Pump base
213	Drive shaft
223	Driven shaft
232	Feed screw right
233	Feed screw left
320	Angular contact ball bearing
325	Needle roller bearing
350	Bearing housing
360	Bearing cap

Item	Designation
365	Closing cap
410	Profile seal
411	Sealing ring
412	O-seal
421	Radial seal
433	Mechanical seal
490	Mechanical seal fixing plate
515	Clamping ring
540	Gear wheel bushing
552	Conical spring washer
554	Washer
562	Cylindrical pin
642	Oil level gauge

Item	Designation
872	Gear wheel
901	Hex bolt
902	Stud screw
903	Locking screw
913	Bleed screw
914	Allen screw
922	Feed screw nut
923	Bearing nut
930	Safety catch
931	Locking plate
932	Lock ring
940	Feather key

11.5 EC Declaration of Conformity

The manufacturer:FRISTAM Pumpen Schaumburg GmbH
Kurt-A.-Körber-Chaussee 55
21033 Hamburg
GERMANY

Business premises in Stadthagen:

Business premises in Stadthagen:
Gubener Str. 1
31655 Stadthagen
GERMANY

hereby declares that the following product (pump with motor):

- Twin screw pump type: FDS
- Serial number: see cover page of the operating guide

complies with all relevant provisions of the **Machinery Directive (2006/42/EC)**.

In addition, the machine complies with all provisions of the **Directives on Electrical Equipment (2014/35/EU), Electromagnetic Compatibility (2014/30/EU)**, Regulation (EC) No. 1935/2004 and FDA.

The following harmonised standards were applied:

- DIN EN 809:2012-10: Pumps and pump aggregates for liquids General safety requirements
- DIN EN ISO 12100:2011-03: Safety of machinery - General principles for design, risk assessment and risk reduction.

Authorised document representative: Torben Hahn

Tel.: +49(0) 5721 / 98206-11

Address: see address of the manufacturer

Stadthagen, 16/06/2016



Torben Hahn / Head of Design and Development

11.6 EC Declaration of Incorporation

The manufacturer:FRISTAM Pumpen Schaumburg GmbH
Kurt-A.-Körber-Chaussee 55
21033 Hamburg
GERMANY

Business premises in Stadthagen:

Business premises in Stadthagen:
Gubener Str. 1
31655 Stadthagen
GERMANY

hereby declares that the following product (pump without motor):

- Twin screw pump type: FDS
- Serial number: see cover page of the operating guide

is an incomplete machine in accordance with **Machinery Directive (2006/42/EC) Annex II B**.

The relevant fundamental safety and health protection requirements in accordance with Annex I of the aforementioned Directive have been applied and complied with.

In addition, the incomplete machine complies with all provisions of Regulation (EC) No. 1935/2004 and FDA.

The incomplete machine may only be put into operation once it has been determined that the machine into which the incomplete machine will be incorporated is in compliance with the provisions of the Machinery Directive (2006/42/EC).

The following harmonised standards were applied:

- DIN EN 809:2012-10: Pumps and pump aggregates for liquids General safety requirements
- DIN EN ISO 12100:2011-03: Safety of machinery - General principles for design, risk assessment and risk reduction

The manufacturer undertakes to electronically transmit the special documentation accompanying the incomplete machine to national authorities on request.

The specialist technical documentation associated with the machine was prepared in accordance with Annex VII Part B.

Authorised document representative: Torben Hahn

Tel.: +49(0) 5721 / 98206-11

Address: see address of the manufacturer

Stadthagen, 16/06/2016



Torben Hahn / Head of Design and Development

12 Appendix 2 – Assembly instructions (optional) for pump with bare shaft

12.1 Safety notice

These assembly instructions are intended exclusively for qualified personnel.

12.2 Application

These assembly instructions are valid for pumps supplied without a motor (optional). Initially, the pump is an incomplete machine.

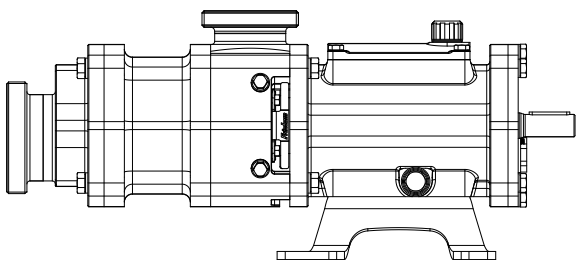

Fig. 15 Incomplete machine: Pump without motor, coupling and base frame

The following information from the “original operating guide” for complete machines is not valid in this case:

- Chapter 11.5 “EC declaration of conformity”, page 21,
- Chapter 2.5.2 “Nameplate”, Page 7.

12.3 Nameplate

Fristam PUMPEN SCHAUMBURG	
Serial Number	123456789
Job-No.	123456789
Year	2016
Pump Weight [kg]	110
Pump	CE Ex II 2G ck(b1) IIB T3
Aggregate	CE Ex II 2G IIB T3
TÜV NORD CERT-Nr.	35182047
Fristam Pumpen Schaumburg GmbH Kurt-A.-Körper-Chaussee 55 D-21033 Hamburg	

FDS 3 - 2			
	Point I	Point II	CIP
Medium			
Q [m³/h]			
T [°C]			
η [mPas]			
pi [barg]			
pd [barg]			
P [kW]			
n [1/min]			
Service			

12.4 Transport without motor

Transport may only be carried out by trained personnel.

The pump may be transported by forklift or by crane.

Always transport pump in the installation position.

12.4.1 Safety notices

Falling or unsecured components

Severe bruises.

- ▶ Always wear safety shoes during all transport work.

Incorrect transport position of the pump

Leakage of corrosive, toxic or contaminating fluids. Personal injury and property damage caused by contamination.

- ▶ Always transport pump in the installation position.

Open, unsealed pipe connections

Property damage caused by contaminants, impacts or moisture in the pump.

- ▶ Do not remove the pipe connection covers until immediately prior to connecting to the pipes.

12.4.2 Transport by forklifts

WARNING

Unsecured components

Death by crushing, bruising of limbs, property damage.

- ▶ Secure the pump against toppling prior to transport. Secure onto the pallet using transport straps or bolt the pump onto the pallet.

Preparation

- ▶ Check whether the pump is adequately secured on the pallet. For instance using straps Fig. 16 “Transport using lift truck”, Page 23.

Procedure

1. Pick up the pallet using the forklift.
2. Carefully transport the pallet to the destination and deposit there.

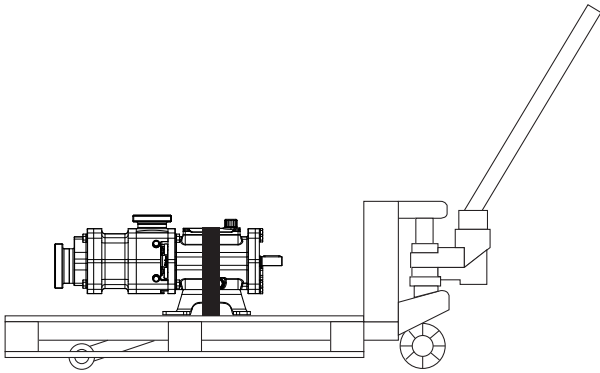

Fig. 16 Transport using lift truck

12.4.3 Transport by crane

⚠ WARNING

Falling parts

Death by crushing, bruising of limbs, property damage.

- ▶ Use only appropriate means of transport and lifting tackle designed to handle the full weight of the pump.

For information on the weight of the pump see the pump nameplate and refer to "Order documents" in the accompanying documents.

- ▶ Do not leave the pump in the raised position longer than necessary.
- ▶ Make sure that there is no one in the area below the pump.

⚠ WARNING

Vibrating parts

Bruising and serious injury.

- ▶ Approach the pump smoothly with the crane and come to a smooth stop.
- ▶ Make sure that there is no one in the danger zone of the pump.

Aids

- Lifting tackle: tested round slings in accordance with DIN EN1492-1 and 1492-2.

Preparation

- ▶ Remove transport safety devices.

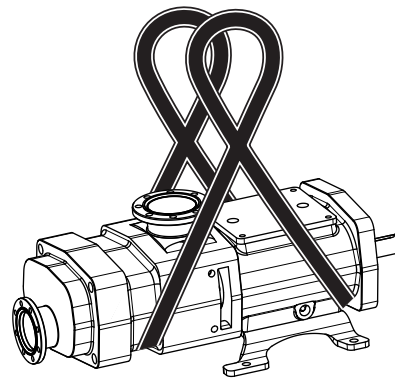

Fig. 17 Transport with round sling

Procedure

1. **Warning:** Damage to and tearing of the round sling. Death by crushing, serious bruising, property damage.

- ▶ Do not let the round sling come into contact with sharp corners and edges.

Wrap the round sling around the housing and drive shaft, see Fig. 17 "Transport with round sling", Page 23

2. Double shaft seal:

Attention: The round sling presses against the barrier water tubes. Damage to double shaft seal.

- ▶ Circumvent the barrier water tubes with the round sling.

3. Lay the slings crosswise over the hook in such a way that the strap cannot slip off the hook.
4. Arrange the centre of gravity to make sure that the pump is lifted in the horizontal position.
5. Lift the pump.

12.5 Installation site

Please refer to operating guide Chapter 6.2 "Installation site", Page 11 for general installation site conditions.

12.6 Mount pump

Prerequisite (supplied by customer)

- Fitting (gear) motor,
- Adequately dimensioned coupling, (flexible coupling, e.g. KTR)
- Shared footprint for gear motor and pump, so that the pump shaft and gear motor shaft can be aligned with one another.

ATTENTION

Incorrectly arranged motor and coupling

Destruction of pump and coupling

- Only use motors and couplings suited to the characteristic curves of the pump. Contact *Fristam* with any questions.

Note: Refer to the coupling supplier's documentation for coupling adjustment dimensions.

Procedure

1. Mount the coupling parts on the drive shaft and the gear shaft.
2. Place the pump on the base frame or foundation so that the drive shaft and gear shaft can be connected to the coupling.
3. Lightly tighten the screw connection on the pump base.
4. Check the centre and angular offset of the drive shaft and gear shaft.
5. Keep the deviations of the angular offset and shaft offset as low as possible. Realign as necessary, or shim components.
6. Bolt the pump and gearbox onto the base frame or foundation.
7. Fasten the coupling in accordance with the coupling manufacturer's specifications.
8. Establish a non-contact guard (coupling guard) in accordance with Machinery Directive 2006/42/EC Chapter 1.4 "Required characteristics of guards and protective devices".
9. The pump is now mounted. Only put the pump into operation if the provisions of the entire machine correspond to the EC Machinery Directive.

Note: Continue with *Chapter 4 "Transport", Page 9*.

Архангельск (8182)63-90-72
Астана (7172)727-132
Астрахань (8512)99-46-04
Барнаул (3852)73-04-60
Белгород (4722)40-23-64
Брянск (4832)59-03-52
Владивосток (423)249-28-31
Волгоград (844)278-03-48
Вологда (8172)26-41-59
Воронеж (473)204-51-73
Екатеринбург (343)384-55-89
Иваново (4932)77-34-06

Ижевск (3412)26-03-58
Иркутск (395)279-98-46
Казань (843)206-01-48
Калининград (4012)72-03-81
Калуга (4842)92-23-67
Кемерово (3842)65-04-62
Киров (8332)68-02-04
Краснодар (861)203-40-90
Красноярск (391)204-63-61
Курск (4712)77-13-04
Липецк (4742)52-20-81
Киргизия (996)312-96-26-47

Магнитогорск (3519)55-03-13
Москва (495)268-04-70
Мурманск (8152)59-64-93
Набережные Челны (8552)20-53-41
Нижний Новгород (831)429-08-12
Новокузнецк (3843)20-46-81
Новосибирск (383)227-86-73
Омск (3812)21-46-40
Орел (4862)44-53-42
Оренбург (3532)37-68-04
Пенза (8412)22-31-16
Казахстан (772)734-952-31

Пермь (342)205-81-47
Ростов-на-Дону (863)308-18-15
Рязань (4912)46-61-64
Самара (846)206-03-16
Санкт-Петербург (812)309-46-40
Саратов (845)249-38-78
Сеvastополь (8692)22-31-93
Симферополь (3652)67-13-56
Смоленск (4812)29-41-54
Сочи (862)225-72-31
Ставрополь (8652)20-65-13
Таджикистан (992)427-82-92-69

Сургут (3462)77-98-35
Тверь (4822)63-31-35
Томск (3822)98-41-53
Тула (4872)74-02-29
Тюмень (3452)66-21-18
Ульяновск (8422)24-23-59
Уфа (347)229-48-12
Хабаровск (4212)92-98-04
Челябинск (351)202-03-61
Череповец (8202)49-02-64
Ярославль (4852)69-52-93

<https://fristam.nt-rt.ru/> || fmg@nt-rt.ru