

Original Instructions
Assembly Instructions

Positive Displacement Pump FKL Series

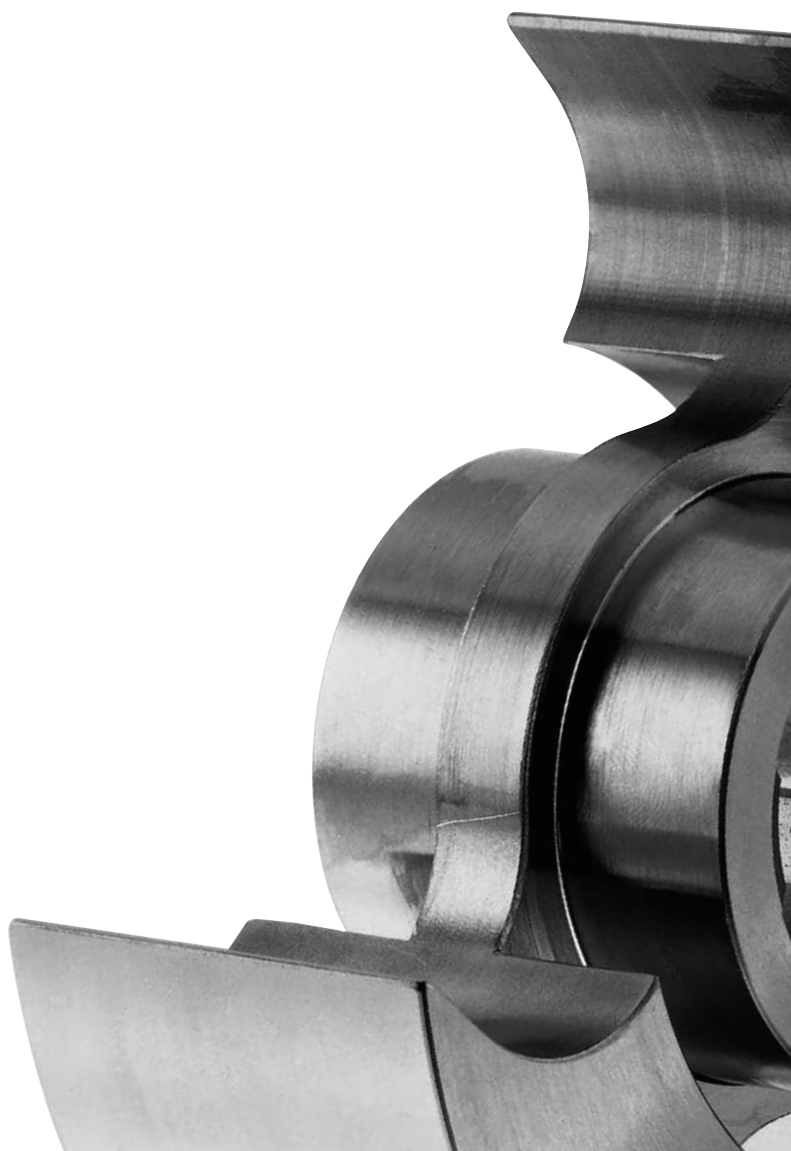

Архангельск (8182)63-90-72
Астана (7172)727-132
Астрахань (8512)99-46-04
Барнаул (3852)73-04-60
Белгород (4722)40-23-64
Брянск (4832)59-03-52
Владивосток (423)249-28-31
Волгоград (844)278-03-48
Вологда (8172)26-41-59
Воронеж (473)204-51-73
Екатеринбург (343)384-55-89
Иваново (4932)77-34-06

Ижевск (3412)26-03-58
Иркутск (395)279-98-46
Казань (843)206-01-48
Калининград (4012)72-03-81
Калуга (4842)92-23-67
Кемерово (3842)65-04-62
Киров (8332)68-02-04
Краснодар (861)203-40-90
Красноярск (391)204-63-61
Курск (4712)77-13-04
Липецк (4742)52-20-81
Киргизия (996)312-96-26-47

Магнитогорск (3519)55-03-13
Москва (495)268-04-70
Мурманск (8152)59-64-93
Набережные Челны (8552)20-53-41
Нижний Новгород (831)429-08-12
Новокузнецк (3843)20-46-81
Новосибирск (383)227-86-73
Омск (3812)21-46-40
Орел (4862)44-53-42
Оренбург (3532)37-68-04
Пенза (8412)22-31-16
Казахстан (772)734-952-31

Пермь (342)205-81-47
Ростов-на-Дону (863)308-18-15
Рязань (4912)46-61-64
Самара (846)206-03-16
Санкт-Петербург (812)309-46-40
Саратов (845)249-38-78
Севастополь (8692)22-31-93
Симферополь (3652)67-13-56
Смоленск (4812)29-41-54
Сочи (862)225-72-31
Ставрополь (8652)20-65-13
Таджикистан (992)427-82-92-69

Сургут (3462)77-98-35
Тверь (4822)63-31-35
Томск (3822)98-41-53
Тула (4872)74-02-29
Тюмень (3452)66-21-18
Ульяновск (8422)24-23-59
Уфа (347)229-48-12
Хабаровск (4212)92-98-04
Челябинск (351)202-03-61
Череповец (8202)49-02-64
Ярославль (4852)69-52-93

Table of Contents

1	Introduction	5	6.4	Pump Fixation	11
1.1	Foreword.....	5	6.5	Installation of Pipes	11
1.2	Manufacturer	5	6.6	Electrical Connection	12
1.3	Scope of Supply.....	5	6.7	Connection of Sealing or Quenching Liquid (Optional).....	12
1.4	Pump Without Motor (Optional)	5	6.8	Cleaning.....	12
1.5	Scope of Documentation	5			
1.6	Display Conventions.....	5	7	Operation	12
2	Safety	6	7.1	Safety Instructions	12
2.1	Basic Safety Instructions.....	6	7.2	Commencement of Operation	12
2.2	Intended Use	6	7.3	Monitoring of Operation	13
2.3	Predictable Misuse	6	7.4	Stopping of Operation	13
2.4	Pump-Specific Safety Instructions	6	7.5	Pump Decommissioning	13
2.5	Warning and Instruction Labels.....	6	8	Cleaning in Place	13
2.6	Noise Emissions	7	8.1	CIP Process.....	13
2.7	Disposal	7	8.2	SIP Process	14
3	Design and Function	7	9	Faults	14
3.1	Principles of Design.....	7	9.1	Safety Instructions	14
3.2	Models	8	10	Maintenance	14
3.3	Basic Versions	8	10.1	Safety Instructions	14
3.4	Pump Sizes	8	10.2	Replacement Parts	14
3.5	Accessories	8	10.3	Inspection of Sealing and Quenching Liquid (Optional).....	14
3.6	Type Designation.....	8	10.4	Oil Level Check.....	15
4	Transportation	9	10.5	Oil Change	15
4.1	Safety Instructions	9	10.6	Lubrication of Motor Bearings.....	15
4.2	Moving With Industrial Truck	9	10.7	Shaft Seal Replacement	15
4.3	Moving With Crane	9	10.8	Pump Casing Removal.....	15
5	Storage	10	10.9	Mounting of the Pump Casing	17
5.1	Pump Storage Conditions.....	10	10.10	Shaft Bearing Replacement	19
5.2	Long-Term Storage	10	10.11	Coupling Replacement.....	19
5.3	Recommissioning	10	10.12	Gear Motor Replacement	19
6	Installation	10	10.13	Checking of the Clearances	20
6.1	Safety Instructions	10	11	Appendix 1	23
6.2	Installation Location	11	11.1	Specifications.....	23
6.3	Reduction of Noise and Vibration.....	11	11.2	Maintenance Intervals	23

11.3	Troubleshooting Table	24
11.4	Number Key	26
11.5	EC Declaration of Conformity.....	28
11.6	EG- Einbauerklärung.....	28
12	Appendix 2 – Assembly Instructions (Optional)	29
12.1	Safety Instructions	29
12.2	Scope.....	29
12.3	Rating Plate	29
12.4	Moving Without Motor	29
12.5	Installation Location	30
12.6	Pump Installation.....	30

1 Introduction

1.1 Foreword

This operator's manual describes all sizes, models, and versions of the FKL Pump Series.

- ▶ Information on the model, size, version, and accessories applicable to your pump can be found on the rating plate on your pump and in the "Order-Related Documents" in the attached documents.

1.2 Manufacturer

FRISTAM Pumpen KG (GmbH & Co.)

Kurt-A.-Körber-Chaussee 55

21033 Hamburg

GERMANY

Tel.: +49-40-72556-0

Fax: +49-40-72556-166

E-mail: info@fristam.de

1.3 Scope of Supply

The package includes the following items:

- Pump with gear motor (= pump unit)
optional: without motor
- Covers for pipe fittings
- Documentation
- *Fristam* accessories (if applicable)
- Optional: assembly kit
- ▶ Check the shipment for completeness and damage. Immediately notify *Fristam* of any missing items or damage.

1.4 Pump Without Motor (Optional)

The pump can optionally be supplied without a motor. In this case, continue reading up to and including chapter 3 „*Design and Function*“, and then skip to *chapter 12, "Appendix 2 – Assembly Instructions (Optional),"* page 29.

1.5 Scope of Documentation

The documentation includes the following items:

- **This operator's manual**
 - Appendix 1 with maintenance, lubrication, and tightening torque tables
 - Appendix 2 with assembly instructions

– Attached documents

- Order-Related Documents
- Supplier documentation (motor, coupling, etc.)
- Documentation on *Fristam* accessories (if applicable)
- Certificates (materials certificates, etc.), if applicable
- Declaration of Conformity or Declaration of Incorporation

1.6 Display Conventions

List items are preceded by dashes:

- Part 1
- Part 2

Handling instructions that must be performed in a specified order are numbered:

1. Turn device on.
2. Turn device off.

Handling instructions that do not need to be performed in a specified order are preceded by triangular bullets:

- ▶ Action
- ▶ Action

1.6.1 Safety Instructions

⚠ DANGER

A safety instruction with the signal word "Danger" indicates personal hazards causing death or serious injury.

⚠ WARNING

A safety instruction with the signal word "Warning" indicates personal hazards that may lead to death or serious injury.

⚠ CAUTION

A safety instruction with the signal word "Caution" indicates personal hazards that may lead to mild to moderate injuries.

NOTICE

A safety instruction with the signal word "Note" warns of the possibility of material damage.

2 Safety

2.1 Basic Safety Instructions

- ▶ Please read this operator's manual completely before using the pump and keep it available at the pump installation location.
- ▶ Heed the applicable national regulations of the owner's country and the company's work and safety regulations.
- ▶ All work described here may only be performed by qualified experts with caution.
- ▶ Danger of contamination: Heed legal and operational safety regulations when pumping dangerous media.

2.2 Intended Use

The standard FKL Pump Series versions are designed for use in the food industry, the pharmaceutical and biotechnology industry, and CIP process technology.

The FKL Pump Series are designed for pumping media at version- and size-specific maximum temperatures and pressures. see *chapter 11.1, "Specifications," page 23.*

The pump flow direction can be selected freely. The FKL Pump Series can generate a vacuum in the suction line.

Each pump is designed according to customer requirements. The seal materials have been selected for the respective medium.

The pump may only be used under the operating conditions specified in the order. Please refer to the *Order-Related Documents*. For other operating conditions, please contact *Fristam*.

2.3 Predictable Misuse

The standard FKL Pump Series versions may not be used in explosive atmospheres. Special explosion-proof versions are available for this.

Pumping of media other than those specified can destroy the pump.

Pumping of foreign objects with the medium can block and destroy the pump.

Standard pump units from *Fristam* are described in this operator's manual. If nonstandard items or extras are installed, the operator assumes the responsibility for operation.

Modifications and changes to the pump are only permissible with the consent of *Fristam*.

2.4 Pump-Specific Safety Instructions

Impermissible Pressure Range

Personal injury and material damage from leakage or bursting of pump.

- ▶ Maintain the pump pressure within the specified pressure range. (see *chapter 11.1.2, "Maximum Discharge Pressures," page 23.*)

Impermissible Temperature Range

Personal injury and material damage from leakage or bursting of pump.

- ▶ Maintain the pump temperature within the specified temperature range. see *chapter 11.1.3, "Maximum Medium Temperatures," page 23.*

Cold Firefighting Water on Hot Pump

Material Damage

- ▶ When extinguishing a fire do not point the water jet at the pump.
- ▶ Let the pump cool down as slowly as possible.

Hot Pump Surface

Contact burns from touching the pump.

- ▶ Check the temperature before touching the pump.
- ▶ Only touch the pump if you are wearing heat-resistant gloves.

Noise Emissions From Running Pump

Hearing damage. The A-weighted sound pressure level of the pump can be greater than 80 dBA.

- ▶ Always wear ear protectors in the vicinity of the running pump.
- ▶ The local noise exposure regulations must be complied with.

2.5 Warning and Instruction Labels

- ▶ Do not alter or remove the labels on the pump.
- ▶ Immediately replace damaged or lost labels with ones that are true to the originals.

2.5.1 Hot Surface



Fig. 1 Safety label: "Hot Surface"

This label indicates that parts can become hot during operation or, if applicable, that hot media is being pumped here. Check the temperature before touching the pump. Only touch the pump if you are wearing suitable gloves.

2.5.2 No Dry Running

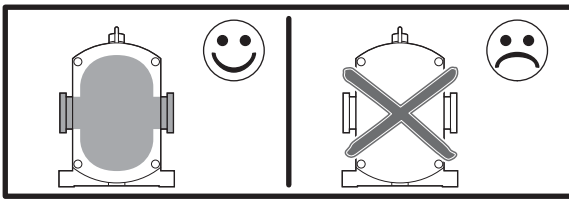

Fig. 2 Safety label: "No Dry Running"

This label indicates that the pump cannot be run dry. There must always be medium in the suction line and the pump when the pump is started. Otherwise, the pump will be damaged.

2.5.3 Rating plate

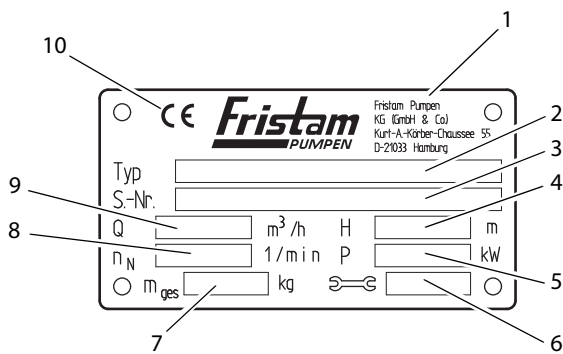

Fig. 3 Rating plate

1	Manufacturer
2	Type: pump series, pump size, model, version
3	S.-Nr.: serial number of the pump
4	H: discharge head [m]
5	P: motor output [kW]
6	Year of manufacture
7	m _{totl} : mass (total) [kg]
8	n _g : rated gear speed [1/min]
9	Q: flow rate [m ³ /h]
10	CE mark

2.6 Noise Emissions

⚠ CAUTION

Noise Generated by Running Pump

Permanent hearing damage.

- ▶ The local noise exposure regulations must be complied with.
- ▶ Wear ear protectors when using pumps with specified sound pressure levels of greater than 80 dBA.

2.7 Disposal

2.7.1 Disposal of Transportation Package

- ▶ Recycle the transportation package.

2.7.2 Disposal of Grease

- ▶ Dispose of grease and objects saturated with grease in an environmentally friendly manner in accordance with applicable regulations.

2.7.3 Disposal of Lubricating Oil

- ▶ Dispose of oil and objects saturated with oil in an environmentally friendly manner in accordance with applicable regulations.

2.7.4 Disposal of Pump

1. Dispose of dangerous or toxic residue in an environmentally friendly manner in accordance with applicable regulations.
2. Carefully clean the pump.
3. Dismantle the pump into its constituent parts.
4. Dispose of the pump parts in an environmentally friendly manner in accordance with applicable regulations.

2.7.5 Disposal of Electrical and Electronic Scrap

- ▶ Dispose of electrical and electronic scrap in accordance with applicable directives.

3 Design and Function

3.1 Principles of Design

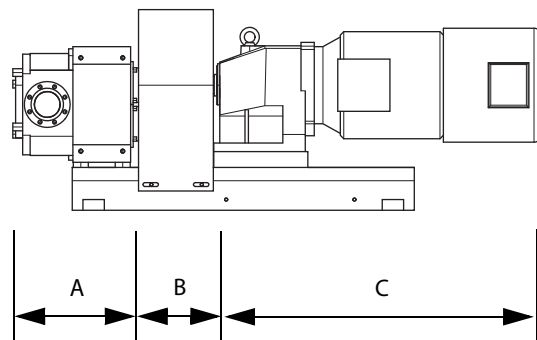

Fig. 4 Principles of design of the FKL pump unit

A	Pump with synchromesh gears
B	Coupling
C	Gear motor

3.1.1 Pump With Synchromesh Gears (A)

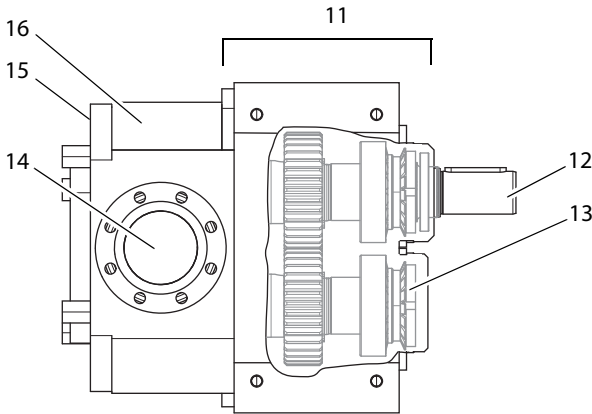

Fig. 5 Principles of design of the FKL positive displacement pump

11	Gearbox
12	Drive shaft
13	Synchronizing shaft
14	Pipe connection
15	Pump cover
16	Pump casing

3.1.2 Coupling (B)

The coupling connects the gear motor shaft to the drive shaft (12) of the pump. The driving torque is transmitted from the gear motor to the pump via the coupling.

3.1.3 Gear Motor (C)

The gear motor is an electric motor with either fixed or variable speed. It is screwed to the base frame or the foundation.

3.2 Models

The model and version are indicated on the rating plate. (see chapter 2.5.3, "Rating plate," page 7.)

The FKL positive displacement pumps are circumferential piston pumps. The FKL Pump Series differ in terms of the pumping element shape.

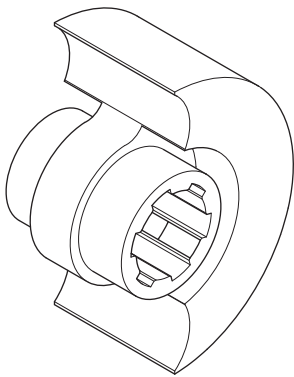

Fig. 6 1-wing rotor

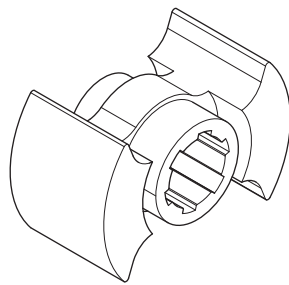

Fig. 7 2-wing rotor

3.3 Basic Versions

For all models, the following versions are available:

- Single or double shaft seal
 - Two seal types are available for use: single and double shaft seals.
 - With the double shaft seal, there are two additional connections for the sealing liquid on the pump casing. These connections are not shown in the figures in this operator's manual.
- High-temperature rotors
 - High-temperature rotors are special rotors that can be used in FKL Pump Series to pump media at elevated temperatures. The clearance is larger in high-temperature rotors. see table 6 , "Clearances," page 20.
- Horizontal or vertical pump connection
- Heating jacket
 - The pump cover and the casing can each be equipped with a heating jacket.
- Rectangular inlet
 - The rectangular inlet is an enlarged opening of the suction port.

3.4 Pump Sizes

Model FKL
FKL 50
FKL 100
FKL 200
FKL 600

Table 1 Pump sizes

3.5 Accessories

The FKL Pump Series can be equipped with the following accessories, among others:

- Enclosure
 - Stainless steel enclosure for the gear motor. The enclosure is fastened to the base frame.
- Spherical cap bearings
 - Spherical cap bearings for pump setup. Spherical cap bearings are attached to the base frame of the pump.

Other accessories are available. If you have any questions, please contact *Fristam*.

3.6 Type Designation

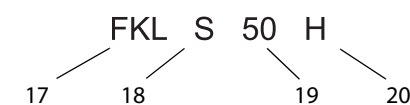

Fig. 8 Type designation example

17	Pump type
18	Supplementary character 1
19	Pump size
20	Supplementary character 2

(17) Pump Type

FKL Circumferential piston pump, self-priming

(18) Supplementary Character 1

S Vertical connections

(19) Pump Size

XX Pump size number

(20) Supplementary Character 2

H Pump casing with heating jacket

h Pump cover with heating jacket

R Rectangular inlet

Note: If the (optional) pump without motor is supplied, please first read *chapter 12, "Appendix 2 – Assembly Instructions (Optional)," page 29.*

4 Transportation

Transportation may only be performed by trained personnel.

The pump unit can be moved using an industrial truck or a crane.

4.1 Safety Instructions

Falling or Unsecured Parts

Severe crush injuries.

- ▶ Always wear gloves when performing transportation-related work.

Incorrect Positioning of Pump for Transportation

Leakage of caustic, toxic, or contaminating liquids. Personal injury and material damage from contamination.

- ▶ Always move the pump in the installation condition.

Open, Unsealed Pipe Fittings

Material damage from contamination, impact, or moisture in the pump.

- ▶ Remove the pipe fitting covers just prior to connection to the pipes.

4.2 Moving With Industrial Truck

⚠ WARNING

Unsecured Parts

Serious injuries, pinching of extremities, material damage.

- ▶ Before moving the pump secure it to prevent it from tipping over. Secure the pump to the pallet with tie-down straps, or screw the pump to the pallet.

Preparation

- ▶ Ensure that the pump is adequately secured to the pallet, for example, with straps; see *fig. 9, "Moving with industrial truck," page 9.*
- ▶ Consider the pump weight when selecting the means of conveyance. Information on pump weight can be found on the pump's rating plate as well as in the *Order-Related Documents* in the attached documents.

Procedure

1. Pick up the pallet with the forks on the industrial truck.
2. Move the pallet to the designated location slowly and smoothly and set down.

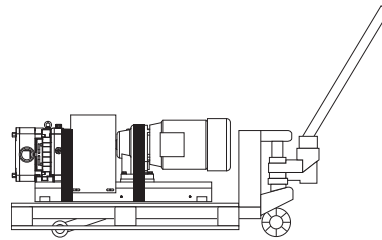

Fig. 9 Moving with industrial truck

4.3 Moving With Crane

⚠ WARNING

Falling Parts

Death from crushing, severe pinching of extremities, material damage.

- ▶ Only use suitable means of conveyance and hoists. Information on the pump weight can be found on the pump's rating plate as well as in the *Order-Related Documents* in the attached documents.
- ▶ Do not lift the pump unit at the eyebolt on the motor or the pump to move because these eyebolts are not designed for the total weight of the pump unit.
- ▶ Do not leave the pump in a raised position for longer than necessary.
- ▶ Ensure that the area below the pump is clear of people.

⚠ WARNING

Swinging Parts

Crushing and serious injuries.

- ▶ Start and stop the crane with pump smoothly.
- ▶ Ensure that the danger zone of the pump is clear of people.

Auxiliary Equipment

Hoists: round slings tested in accordance with DIN EN 1492-1 and 1492-2

Preparation

- ▶ Remove load-securing devices.

Procedure

1. **Warning:** Round sling damage and tearing. Death from crushing, severe pinching, material damage.
 - ▶ Do not lay the round sling over any sharp edges or corners.

Wrap the round sling around the gear motor; see *fig. 10*, "Moving with round sling," page 10.
2. Wrap the other end of the round sling around the pump casing; see *fig. 10*, "Moving with round sling," page 10.
3. For double shaft seal:

Note: Round sling compresses sealing water tubes. Material damage to double shaft seal.

 - ▶ Do not lay the round sling on the sealing water tubes.
4. Guide both loops to the crane hook, rotate, and hook over the hook to ensure that the belt will not slip on the hook.
5. Position the center of gravity to ensure that the pump is lifted horizontally.
6. Lift the pump.

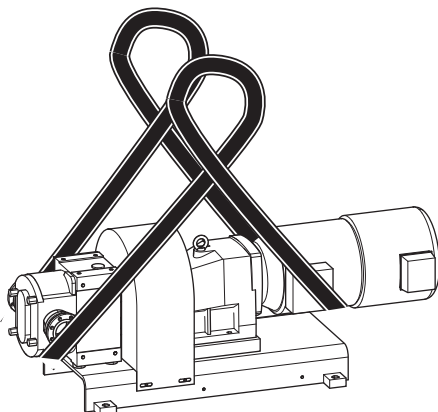

Fig. 10 Moving with round sling

5 Storage

5.1 Pump Storage Conditions

Store the pump as follows:

- Dry, in low humidity
- Protected against frost and heat, optimally at a temperature of 20°C to 25°C
- Ventilated
- Dust-free
- ▶ All movable pump parts must be rotated every three months.

5.2 Long-Term Storage

For a storage time of longer than six months, heed the following:

- ▶ The shaft seals must be completely removed and stored separately before long-term storage of the pump.

See *chapter 10.8, "Pump Casing Removal," page 15* and *chapter 5.2.1, "Storage of Elastomers," page 10*.

5.2.1 Storage of Elastomers

Store the elastomers as follows:

- Storage temperature between +5°C and +20°C
- Relative air humidity below 70%
- No direct sunlight
- Deformation-free storage

5.3 Recommissioning

- ▶ After long-term storage and before commissioning, check seals, bearings, and oil level.

6 Installation

6.1 Safety Instructions

Falling or Unsecured Parts

Severe crush injuries.

- ▶ Always wear gloves when performing installation-related work.

Incomplete, Unstable Installation

Severe crush injuries, material damage.

- ▶ Tighten screws to the specified tightening torque; see *chapter 11.1.1, "Tightening Torques," page 23*.

- ▶ Use a torque wrench or an impact driver with adjustable torque.

Swinging During Adjustment of Spherical Cap Feet

Material damage to system and pump.

- ▶ Use spherical cap base plates.

6.2 Installation Location

For standard pumps, the installation location must meet the following requirements:

- Nonexplosive atmosphere
- Dust-free environment
- Ambient temperature: -20°C to $+40^{\circ}\text{C}$
- Values for moisture and salt contents in ambient air as given in the motor supplier documentation in the attached documents.
- Foundation sized adequately for the pump weight
- Horizontal and level installation surface, adequate installation surface strength for pump mass.
- Installation clearances as given in the motor supplier documentation
- Adequate clearance for maintenance work
- Adequate air supply for motor cooling

6.3 Reduction of Noise and Vibration

6.3.1 Primary Measures

- Operate the pump in the optimum working range.
 - ▶ Operate the pump without cavitation (see chapter 6.5, "Installation of Pipes," page 11).
- Decouple the suction and discharge lines from vibrations.
 - ▶ Support lines.
 - ▶ Align lines.
 - ▶ Install vibration dampers.

6.3.2 Secondary Measures

- ▶ Take structural measures such as the following:
 - Acoustic paneling
 - Enclosure in housing

6.4 Pump Fixation

6.4.1 Pump With Base Frame

- ▶ Screw the pump on the base frame to the foundation.

6.4.2 Pump With Base Frame on Spherical Cap Bearings (Optional)

- ▶ Set up the pump on the spherical cap bearings and align.

6.4.3 Carriage (Optional)

1. Set up the pump at the installation location. Lock the locks on the rollers (if present) or secure the carriage with chocks.
2. Ground the carriage to dissipate electrostatic charge.
3. Position hose line to ensure that it cannot be damaged.

6.5 Installation of Pipes

Lay and connect pipes as follows:

- ▶ Keep the pipe resistance as low as possible: Avoid unnecessary installation of valves, elbows, and abrupt pipe transitions.

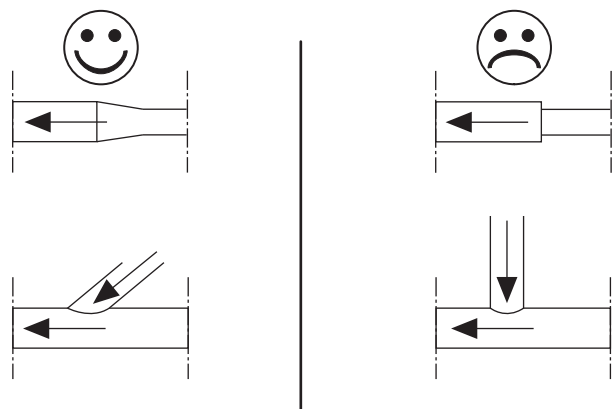

Fig. 11 Pipe transitions

- ▶ Design pipe cross section so that no unnecessary pressure losses or cavitation occurs in the suction and inlet areas.
- ▶ Install a shut-off valve in the discharge line.
- ▶ Design the suction lines to be as short as possible.
- ▶ Install the suction lines in horizontal position or at a constant dropping angle towards the pump unit. Rule out the possibility of air pockets and dips in the pipes.

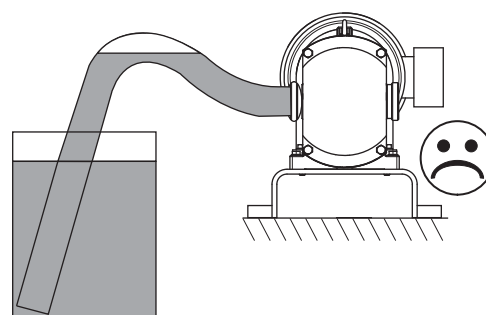

Fig. 12 Air pocket in pipe

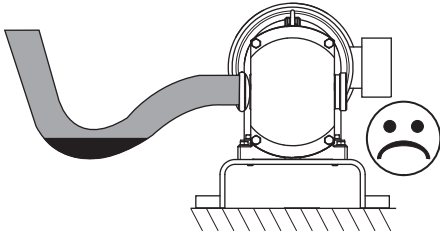

Fig. 13 Dip in pipe

- ▶ Lay and connect the pipes to ensure that no stresses are applied to the pump.
- ▶ Secure pipes to ceilings, walls, or floor using pipe clamps.
- ▶ Align pipes flush with pump connections using a bracket.

6.6 Electrical Connection

⚠ WARNING

Electrostatic Charge Buildup

Electric shock.

- ▶ Ground pipes and pump to dissipate electric charge.

Electrical connection may only be performed by a qualified electrician.

Procedure

1. Heed the connection values on the motor's rating plate. The specified voltage must not be exceeded.
2. Only connect the motor to fuse-protected circuits to prevent excessive current consumption.
3. Connect the motor according to the circuit diagram in the terminal box of the motor.
4. Protect cable feedthroughs against penetration by moisture.
5. Turn on the motor for 2 to 3 seconds. Check the direction of rotation of the motor fan wheel.
6. Reverse the polarity if the direction of rotation is incorrect.

6.7 Connection of Sealing or Quenching Liquid (Optional)

For versions with double shaft seals, the shaft seal chamber must be flushed with sealing or quenching liquid.

- ▶ Use a suitable medium as a sealing or quenching liquid.

6.7.1 Installation of Pipes

1. Install and seal the supplied flushing tubes.
2. Install the inlet line on the **bottom** of the shaft seal.
3. Install the drain line on the **top** of the shaft seal.
4. Install the following fittings in the pipes:
 - Throttle valve in inlet line
 - Flowmeter (pressure gauge) in drain line

6.8 Cleaning

Only use cleaning agents that comply with the hygiene guidelines for the respective pumping medium.

1. Before sealing the pump ensure that there are no foreign objects inside the pump or pipes.
2. Seal the pump.
3. Connect the pipes.
4. Thoroughly clean the pump and the pipe system before initial use.

7 Operation

7.1 Safety Instructions

Closed Valve in Discharge Line

Serious personal injury and material damage from bursting of system due to excessive pressure buildup.

- ▶ Before turning on and during operation of the system, ensure that all valves in the discharge line are open.
- ▶ Install bypass for pressure limitation.

Closed Valve in Suction Line

Damage to shaft seal by dry running of pump.

- ▶ Before turning on and during operation of the system, ensure that all valves in the suction line are open.
- ▶ Regulate the pump output only by means of the discharge-side valve.

No Medium in Pump

Dry running of pump. Damage to shaft seal.

- ▶ Ensure that there is always medium in the pump before and during operation.

7.2 Commencement of Operation

NOTICE

For double shaft seal: Stoppage of Sealing Liquid

Damage to shaft seal.

Ensure that during operation:

- ▶ The sealing liquid flows with the necessary pressure through the double shaft seal.

The prescribed sealing fluid pressure is specified in the "Order-related documents" in the sectional drawing of the shaft seal. The "Order-related documents" are included in this operating manual.

- Negative pressure in the seal chamber is not allowed.

If no pressure is noted in the "Sectional drawing of the shaft seal", the following applies:

- A max. pressure of 0.2 bar is allowed for seals to which sealing fluid is applied without pressure or which are flushed.

- ▶ The temperature of the sealing liquid is maintained at $T < 70\text{ }^{\circ}\text{C}$.

1. Open the valve in the suction line.
2. Open the valve in the discharge line.
3. Fill the pump and the suction line up to the upper edge of the pump with pumping medium. Allow any air pockets that are present to escape.
4. Only for pumps with sealing or quenching liquid:
Check the required sealing pressure. For the maximum sealing pressure, see the specifications on the *Sectional Drawing of the Shaft Seal* in the attached documents.
5. Turn on the motor.

7.3 Monitoring of Operation

Follow the safety instructions given below while the pump is operating.

NOTICE

Foreign Objects in Pumping Medium

Blocking of rotors and shearing off of shafts.

- ▶ Rule out the possibility of foreign objects in the pumping medium.
 - Install a current limiter to protect the gear motor.

NOTICE

Sudden Closing of Valves in Discharge Line

Damage to pumping medium by water hammers in the pump.

- ▶ During operation do not close the valve in the discharge line abruptly or for a long period of time.

NOTICE

Rapid Cooling of Pump

Tension cracks in pump.

- Do not rapidly cool the pump.

NOTICE

Cavitation and Dry Running of Pump

Damage to shaft seal.

- Ensure that suction-side valves are open during operation.

7.4 Stopping of Operation

1. Turn off the motor.
2. Close the valve in the suction line to prevent dry running of the pump.
3. Close the valve in the discharge line.

7.5 Pump Decommissioning

1. Turn off the motor.
2. Close the valve in the suction line.
3. Close the valve in the discharge line.
4. De-energize the pump.
5. Empty the pump.
6. Clean the pump as described in *chapter 6.8, "Cleaning," page 12*.
7. Dry the pump.
8. Protect the interior of the pump from moisture, e.g., with silica gel.
9. Seal the pipe connections with caps to prevent penetration of dirt and foreign objects.
10. For additional steps, please see *chapter 5, "Storage," page 10*.

8 Cleaning in Place

8.1 CIP Process

The FKL Pump Series are suitable for the CIP (Cleaning In Place) process.

Example of a Cleaning Cycle

1. Perform preliminary flush with water.
2. Perform caustic flush with lye (NaOH; see *table 2, "CIP cleaning," page 13*).
3. Perform intermediate flush with water.
4. Perform acid flush with nitric acid (HNO₃; see *table 2, "CIP cleaning," page 13*).
5. Flush with water.

The pump's differential pressure should be 2–3 bar so that adequate flow rates are reached in the pump.

Medium	Process Temperature [°C]
NaOH (approx. 1% to 2%)	80 to 85
HNO ₃ (approx. 1%)	60 to 65

Table 2 CIP cleaning

If values deviate from these specifications, please contact *Fristam*.

8.2 SIP Process

NOTICE

Dry Running of Pump With Vapor

Damage to shaft seal.

- ▶ If vapor is flowing through the pipes, ensure that the pump is off.

The FKL Pump Series can only be used with the SIP (Sterilization In Place) process with the prior approval of *Fristam*.

Suitability depends on the selected elastomers.

The maximum process temperature is 145°C.

In ATEX operation, temperatures might deviate, see supplementary ATEX manual, "Temperature limits".

9 Faults

For information on faults, possible causes, and remedies, please see *chapter 11.3, "Troubleshooting Table," page 24*.

9.1 Safety Instructions

Hot Pump Surface

Contact burns from touching the pump. Pumping of hot media can cause the pump to become very hot.

- ▶ Let the pump cool down completely before working on it.
- ▶ Check the temperature before touching.
- ▶ Only touch the pump if you are wearing heat-resistant gloves.

10 Maintenance

For information on maintenance intervals, please see *chapter 11.2, "Maintenance Intervals," page 23*.

10.1 Safety Instructions

Rotating Parts

Personal injury and material damage.

- ▶ Before working on the pump **always** turn off the pump motor and prevent it from being able to be turned on accidentally.

Falling or Unsecured Parts

Severe crush injuries.

- ▶ Always wear gloves when performing maintenance-related work.

Uncontrolled Outflow of Liquids

Personal injury and material damage from acid burns, poisoning, or contamination.

Before performing maintenance or cleaning work on the pump:

- ▶ Close the suction and discharge valves in front of and behind the pump.
- ▶ For double shaft seal: Block off the sealing or quenching liquid line.
- ▶ Before opening the pump completely empty the pump casing.

Rapid Cooling of Pump

Tension cracks in pump.

- ▶ Do not rapidly cool the pump.

Use of Hard Driving Tools

Scratching of polished surfaces.

- ▶ For polished surfaces, use a copper socket wrench socket.

10.2 Replacement Parts

Use of replacement parts that are not approved by *Fristam* can lead to serious personal injury and material damage. If you have any questions regarding approved replacement parts, please contact *Fristam*.

Fristam registers all shipped pumps. For ordering replacement parts, you require the following information:

1. Serial number of pump: See rating plate or number stamped into pump.
2. For replacement parts and materials designations, please see *Order-Related Documents* in the attached documents.

10.3 Inspection of Sealing and Quenching Liquid (Optional)

For pumps equipped for "locking system" or "quenching system" the sealing liquid head must be checked. For information on maintenance intervals, please see *table 9 on page 22*.

- ▶ Check the sealing liquid head and compare with the specified value.

The specified value can be found on the *Sectional Drawing of the Shaft Seal* in the *Order-Related Documents*. The *Order-Related Documents* are attached to this operator's manual.

The sealing liquid is heated by hot pumping medium and by operation of the pump.

- ▶ Ensure that the temperature T of the sealing liquid is < 70°C during operation.

10.4 Oil Level Check

The oil is checked on the oil level sight glass (23), which can be found on the side of the gearbox.

For information on maintenance intervals, please see *table 9* on page 22.

10.5 Oil Change

Change the oil in the FKL Pump Series at regular intervals. For information on maintenance intervals, please see *table 9* on page 22.

Maintenance Intervals

Change the oil once a year or every 4,000 operating hours.

Under severe operating conditions such as high humidity, aggressive environment, or large temperature fluctuations, the oil should be changed every 2,000 operating hours.

Lubricants and Amounts

For the required amount, please see *table 3*, "Oil volumes for model FKL," page 15.

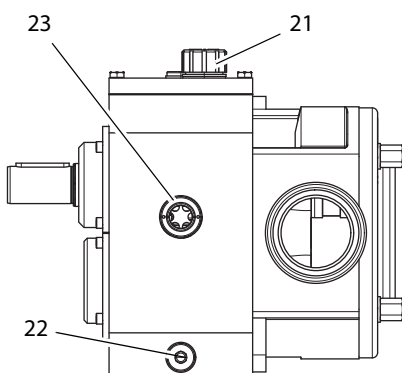

Fig. 14 Oil change

21	Bleed screw
22	Screw plug
23	Oil level sight glass

Procedure

1. Turn on the motor and let it run until the normal operating temperature is reached.
2. Turn off the motor and prevent it from being able to be turned on accidentally.
3. Place a suitable oil collection container under the screw plug (22).
4. **Caution!** Danger of burning from hot oil.
 - ▶ Wear heat- and oil-resistant gloves.
 Loosen the bleed screw (21).
5. Loosen and remove the screw plug (22).
6. Drain the oil completely and dispose of oil in accordance with local regulations.

7. Clean the bleed screw and the seals.
8. Install the screw plug and the bleed screw with the corresponding seals.
9. Fill with new oil, monitoring the oil level on the oil level sight glass (23) in the process.

Pump Size	Expected Oil Volume [l]		Oil
	Horizontal Orientation of Pipe Connections	Vertical Orientation of Pipe Connections	
FKL 50	1.6	1.5	SAE 15W40
FKL 100	5.0	4.6	
FKL 200	7.5	6.5	
FKL 600	20.0	18.0	

Table 3 Oil volumes for model FKL

10.6 Lubrication of Motor Bearings

- ▶ Lubricate the motor bearings in accordance with the gear motor manufacturer's specifications. Please refer to the supplier documentation in the attached documents.

10.7 Shaft Seal Replacement

Replace the shaft seal if:

- Pumping medium or sealing or quenching liquid flows out of the pump on the atmosphere side.
- Sealing or quenching liquid leaks into the pumping medium.

Overview of Procedure

1. Remove the pump casing; see *chapter 10.8*, "Pump Casing Removal," page 15.
2. Replace the shaft seal; see *chapter 10.9.2*, "Mounting of the Shaft Seals," page 18.
 - ▶ Preassemble the pump casing.
 - ▶ Mount the shaft seal.
3. Mount the pump casing.
4. Mount the rotors.
5. Attach the pump cover.

The exact procedure is described in the following sections.

10.8 Pump Casing Removal

In the following assembly steps, differentiation is made between inner and outer shaft seals; see the attached *Sectional Drawing of the Shaft Seal*.

– Inner Shaft Seal

In this case, the profile seal (410.62) and the stationary seal ring (475.60) are situated in the groove on the rotor. The related components can be found on the *Sectional Drawing of the Shaft Seal*.

– **Outer Shaft Seal**

In this case, there are no shaft seal components in the groove on the rotor.

Note: Only outer shaft seals are used for the FKL 600 model.

Preparation

1. Prior to disassembly check the *Sectional Drawing of the Shaft Seal* to determine which type of shaft seal is present.
2. Turn off the motor and prevent it from being able to be turned on accidentally.
3. Close the valve in the discharge line.
4. Close the valve in the suction line.
5. For double shaft seal: Block off the sealing or quenching liquid line.
6. Completely empty the pump.
7. Loosen the suction and discharge connections.
8. Take the pump out of the system.

Procedure

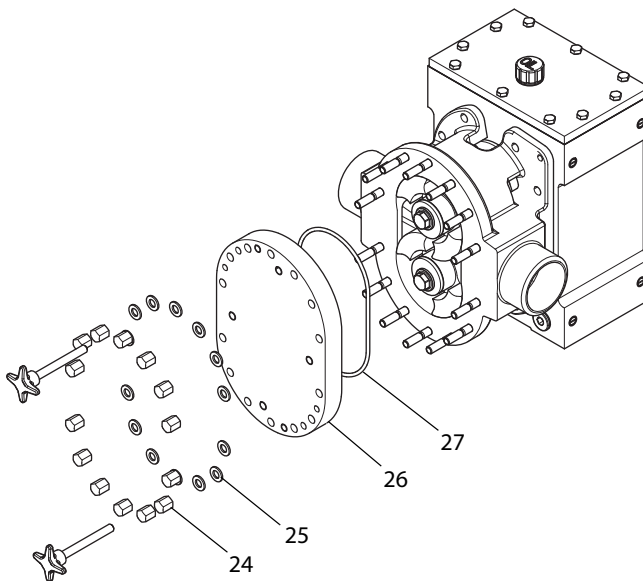

Fig. 15 Detachment of pump cover illustrated using the FKL100

1. Loosen the nuts (24) on the pump cover.
2. Remove the nuts, the washers (25), the pump cover (26), and the cover seal (27).

Note for models 50, 100, and 200: There are two forcing screws with star knobs on the pump cover. If the pump cover is hard to detach:

- ▶ Rotate the forcing screws clockwise until the cover detaches.

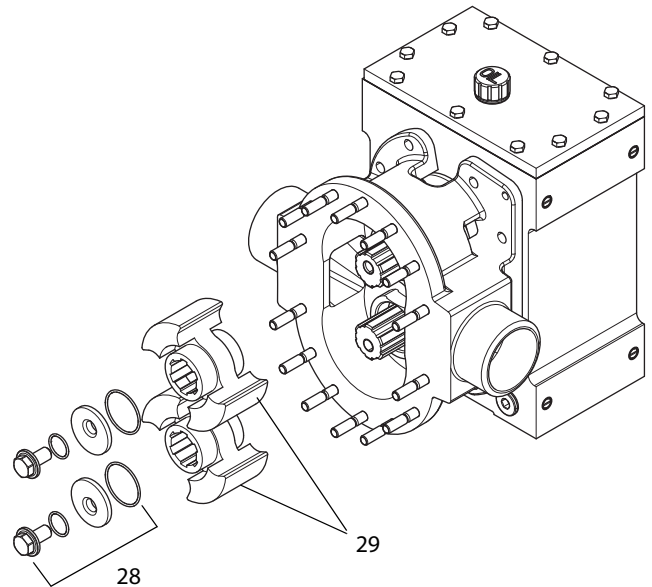

Fig. 16 Removal of rotors illustrated using the FKL100

3. **Warning:** Rotating machine parts. Severe pinching of hands.
 - ▶ Block the rotors (29) with wooden or plastic wedges.
 Loosen and remove the rotor fasteners and the corresponding seals (28).
4. Take the rotors off of the drive and synchronizing shafts.
5. Depending on the given shaft seal type, continue with chapter 10.8.1, "Removal of Inner Shaft Seal," page 16 or chapter 10.8.2, "Removal of Outer Shaft Seal," page 17.

10.8.1 Removal of Inner Shaft Seal

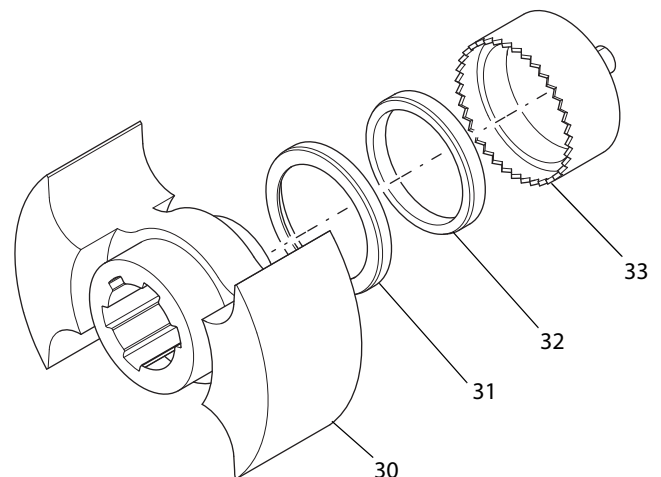

Fig. 17 Removal of stationary seal ring from rotor

1. Open the profile seal (31) using the supplied tool (33). The stationary seal ring (32) detaches from the rotor (30) and can be removed.
2. Remove the profile seal from the rotor.

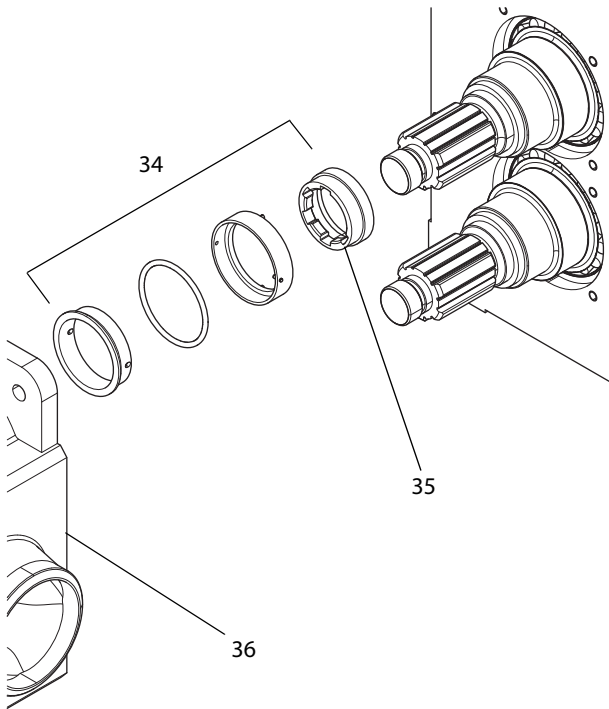

Fig. 18 Exploded view of the FKL100, single shaft seal

3. Remove the rotating seal rings from the pump casing using a hook wrench.

Note: The pump casing does not need to be disassembled for this.

Note: Loss of stationary bushings (35). Material damage.

- ▶ Determine the position of the stationary bushing. The stationary bushings are shown on the *Sectional Drawing of the Shaft Seal* in the *Order-Related Documents*. The stationary bushings are marked by prick punch marks (indentations).
- ▶ Take the shaft seals (34) off of the pump casing (36) and the shafts. Remove the stationary bushings (35).

4. Store the stationary bushings separately.
5. Remove the pump casing.
6. Please check the attached *Sectional Drawing of the Shaft Seal* to determine the remaining shaft seal disassembly steps.

Only for double shaft seal:

- ▶ Remove heavily worn shaft protective sleeves and replace with new ones.

10.8.2 Removal of Outer Shaft Seal

1. Only for double shaft seal: Remove sealing water tubes if necessary.
2. Unscrew the fastening screws on the pump casing.

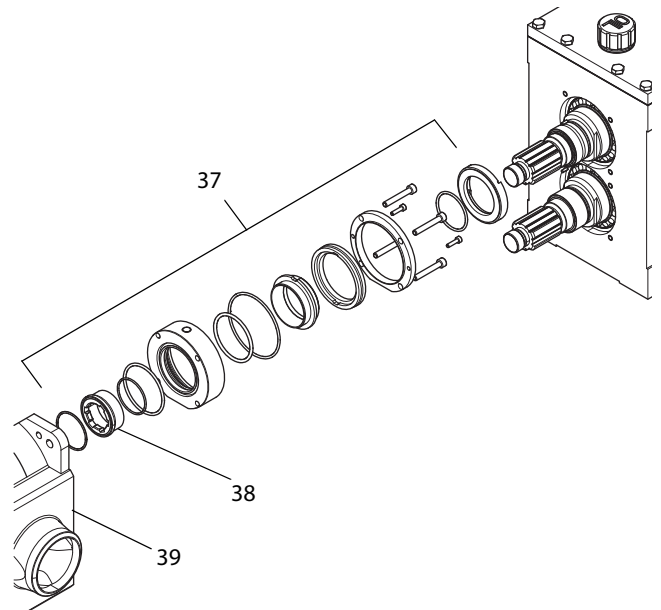

Fig. 19 Removal of shaft seal illustrating using the FKL100, single shaft seal

3. Carefully loosen the pump casing from the synchromesh gear using a plastic hammer and remove.
4. **Note:** Loss of stationary bushing (38). Material damage.
 - ▶ Determine the position of the stationary bushing. The stationary bushings are shown on the *Sectional Drawing of the Shaft Seal* in the *Order-Related Documents*. The stationary bushings are marked by prick punch marks (indentations).
 - ▶ Take the shaft seals (37) off of the pump casing (39) and the shafts. Remove the stationary bushings (38).
5. Store the stationary bushings separately.
6. Only for double shaft seal: Unscrew the shaft seal on the back of the pump casing.
7. Please check the attached *Sectional Drawing of the Shaft Seal* to determine the remaining shaft seal disassembly steps.

10.9 Mounting of the Pump Casing

The pump assembly is dependent on the respective pump size and model as well as the respective shaft seal. To determine which shaft seal you have, please see the *Order-Related Documents*.

NOTICE

Incorrect Elastomers

Pump leakiness.

- ▶ Ensure that the elastomers are appropriate for the condition of the pumping medium. Please refer to the *Order-Related Documents*.

Preparation

- ▶ Clean all pump parts. Check for damage and accuracy of fit.

- ▶ If necessary, rework or replace pump parts.
- ▶ Assemble carefully in clean conditions. The seals can easily be damaged.
- ▶ Replace all O-rings.
- ▶ To reduce friction, wet the O-rings and the sliding faces with water, alcohol, or silicone grease.
- ▶ Clean the sealing surfaces of the mechanical seals with a degreaser, e.g., OKS 2610 Universal Cleaner. Do not allow the sealing surfaces to come into contact with oil or grease and do not touch with your fingers afterwards.

Tip: The joint retaining compound "Euro Lock A64.80," e.g., is suitable for gluing in bearings and bushings.

Tip: The screw retaining compound "Euro Lock A24.10," e.g., is suitable for gluing in set screws.

10.9.1 Important Markings

The rotors and stationary bushings must not be mixed up. They have been adapted to the synchronizing shaft or the drive shaft and are marked by prick punch marks (indentations).

- ▶ Before installing the stationary bushings and the rotors check the markings:
 - One indentation for drive shaft
 - Two indentations for synchronizing shaft

10.9.2 Mounting of the Shaft Seals

The shaft seal built into the respective pump is given in the *Order-Related Documents* in the form of a *Sectional Drawing of the Shaft Seal* and a Replacement Parts List.

Procedure

1. Mount the shaft seal with the aid of the *Sectional Drawing of the Shaft Seal*.
2. Mount the pump casing on the gearbox.
 - Note:** Contamination between gearbox and pump. Material damage from warpage of pump casing.
 - ▶ Ensure that the pump is lying flat on the gearbox.
3. Screw on the pump casing.
4. Ensure that safety devices such as covers are installed on the pump casing.

10.9.3 Mounting of the Rotors

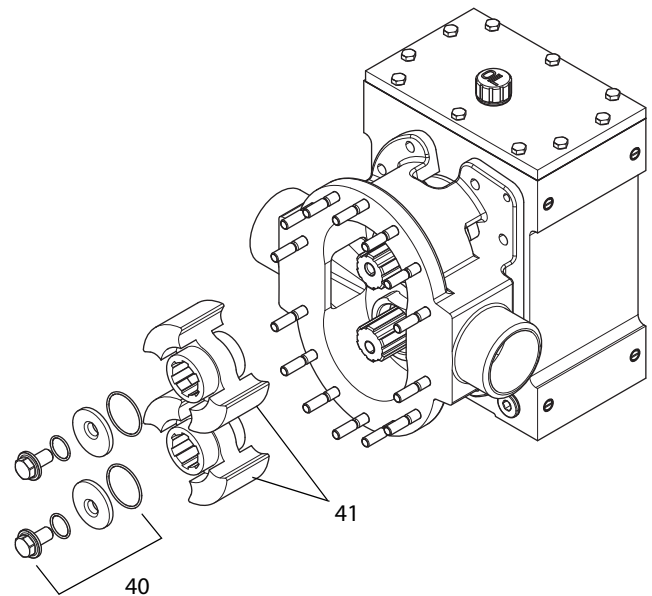

Fig. 20 Installation of rotors illustrated using the FKL100

1. **Note:** Mixing up of the two rotors. Material damage during pump operation from rotor blockage or scraping. The rotors are designed for either the drive shaft or the synchronizing shaft. (see chapter 10.9.1, "Important Markings," page 18.)
 - ▶ Mount the rotors (41) with seals on the appropriate shafts.
2. Attach the rotor fasteners (40) as follows according to the fastener type:
 - Rotor Nuts**
 - ▶ Open the polyamide snap ring and place in the shaft groove.
 - ▶ Screw the rotor nut hand-tight onto the shaft.
 - Rotor Screws**
 - ▶ Place O-rings and washer on the rotor screw.
 - Only for models FKL 100 and 200: Place O-rings and eccentric washer on the rotor screw.
 - ▶ Screw the rotor screw hand-tight into the shaft.
 - Only for models FKL 100 and 200: Align the eccentric washer with the shaft.
3. **Warning:** Rotating machine parts. Severe pinching of hands.
 - ▶ Block the rotors with wooden or plastic wedges.
4. Tighten the rotor fasteners to the specified tightening torque. (see table 4 , "Tightening torques for rotor fasteners," page 19.)

Model	Pump Size	Thread	Rotor Fastener Tightening Torque [Nm]	
			Rotor Nut	Rotor Screw
FKL	50	M24 x 1.5	100	
	100	M16 x 1.5	85	
	200	M16 x 1.5	130	
	600	M42 x 2	250	

Table 4 Tightening torques for rotor fasteners

10.9.4 Pump Sealing

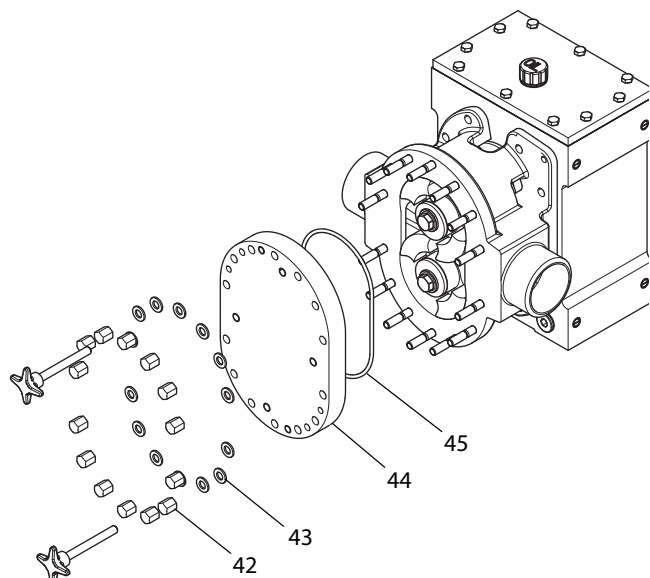

Fig. 21 Fastening of pump cover illustrated using the FKL100

1. Equip the pump cover (44) with an O-ring (45).
2. Slide the pump cover onto the pump casing.
3. Screw the pump cover onto the pump casing with nuts (42) and washers (43).

10.10 Shaft Bearing Replacement

- Contact *Fristam*.

10.11 Coupling Replacement

- Only use couplings designed for the FKL Pump Series.

The coupling size must be adequately selected according to the performance data of the pump and the motor. If you have any questions, please contact *Fristam*.

Procedure

1. Turn off the motor and prevent it from being able to be turned on accidentally.
2. Remove the coupling guard.
3. Loosen the gear motor from the base frame or the foundation and remove.

4. Loosen the coupling according to the coupling manufacturer's specifications. Please see the attached supplier documentation for the coupling.
5. Dispose of the old coupling parts in an environmentally friendly manner.
6. Mount new coupling parts on the pump shaft and the motor shaft.
7. Place the pump on the base frame so that the pump shaft can be connected to the motor shaft with the coupling.
8. Screw the pump loosely onto the base frame or the foundation.
9. Check the parallel and angular misalignment of the shafts.

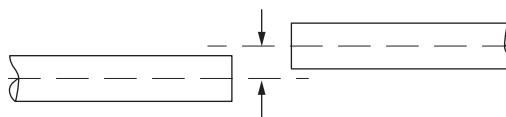

Fig. 22 Parallel misalignment

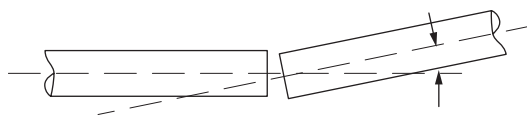

Fig. 23 Angular misalignment

10. Minimize deviations from the angular and parallel misalignment. Realign or shim the shafts if necessary.
11. Screw the pump and motor to the base frame or the foundation.
12. Fasten the coupling according to the coupling manufacturer's specifications.
13. Mount the coupling guard.

10.12 Gear Motor Replacement

Coupling

The coupling installation manual can be found in the supplier documentation.

NOTICE

Gear Motor Oversized

Use of an incorrectly sized gear motor can result in serious damage to the pump unit.

- Only replace the gear motor with one with the same rating; see motor supplier documentation.

Procedure

1. Turn off the gear motor and prevent it from being able to be turned on accidentally.
2. Remove the coupling guard.
3. Loosen the coupling according to the coupling manufacturer's specifications and remove.
4. Take the coupling parts off of the gear motor.

5. Detach the old gear motor from the base frame or the foundation.
6. Dispose of the old gear motor. (see *chapter 2.7, "Disposal," page 7.*)
7. Remove protective coatings and grease from all coupling parts.
8. Mount the coupling parts on the pump shaft and the motor shaft.
9. Place the replacement motor on the base frame or the foundation and fasten.
10. Continue as described in "Check the parallel and angular misalignment of the shafts" in *chapter 10.11, "Coupling Replacement," page 19, starting with step 9.*

10.13 Checking of the Clearances

The clearance ensures that the rotors can rotate freely. The clearance must be checked if the following parts are replaced:

- Shaft bearing and shaft
- Rotor
- Pump casing

Measurement Types

The clearance must be measured between the rotor and the pump casing. The following dimensions must be measured:

- Axial clearance; the measurement depends on the position of the rotors on the shafts.
- Radial clearance; the measurement depends on the position of the pump casing on the gearbox.

10.13.1 Preparation of Pump for Measurement

Prerequisites

- Pump cover has been removed.
- Rotors have been removed.

Procedure

1. **Note:** Mixing up of the two rotors. Material damage during pump operation from rotor blockage or scraping. The rotors are designed for either the drive shaft or the synchronizing shaft. (see *chapter 10.9.1, "Important Markings," page 18.*)
 - ▶ Mount the rotors (41) with O-rings on the appropriate shafts.
2. Attach the rotor fasteners (40) as follows according to the fastener type:

Rotor Nuts

Note: The polyamide snap ring is not attached for the clearance measurement.

- ▶ Screw the rotor nut hand-tight onto the shaft.

Rotor Screws

- ▶ Place O-rings and washer on the rotor screw.

Only for models FKL 100 and 200: Place O-rings and eccentric washer on the rotor screw.

- ▶ Screw the rotor screw hand-tight into the shaft.

Only for models FKL 100 and 200: Align the eccentric washer with the shaft.

3. Block the rotors with wooden or plastic wedges.
4. Tighten the rotor fasteners to the specified tightening torque. (see *table 4, "Tightening torques for rotor fasteners," page 19.*)

Model	Pump Size	Thread	Tightening Torque [Nm]
FKL	50	M24 x 1.5	50
	100	M16 x 1.5	85
	200	M16 x 1.5	130
	600	M42 x 2	250

Table 5 Tightening torques for rotor fasteners during clearance measurement

10.13.2 Measurement of Axial Clearance

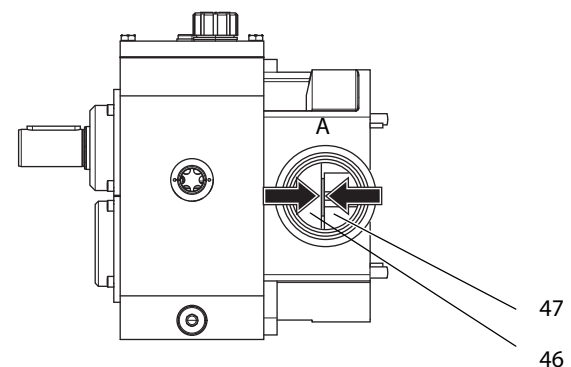

Fig. 24 Measurement of axial clearance

Prerequisites

Pump has been prepared for the measurement.

Procedure

1. Measure the clearance **A** between the pump casing (46) and the rotor (47) at several points using vernier calipers.
2. **Note:** If the clearance is too small, the pump could be destroyed.
 - ▶ Check your order documents to determine if standard or high-temperature rotors are installed in the pump. If necessary, contact *Fristam*.
3. Compare the clearance with the value in *table 6, "Axial clearances," page 21.*

Note: When rotors are used they undergo wear. This increases tolerance ranges slightly.

Pump Size	Axial clearances [mm]		
	Standard Rotors (up to 15 bar)	High-Pressure Rotors (15 bar and higher)	High-Temperature Rotors
FKL 50	0.06–0.08	0.06–0.08	0.11–0.13
FKL 100	0.10	0.15	0.20
FKL 200	0.10	0.15	0.22
FKL 600	0.25	-	-

Table 6 Axial clearances

4. If the clearance is not within the specified tolerance range:

Clearance too large

► (see chapter, "Grinding of Stationary Bushing," page 21.)

Clearance too small

► (see chapter, "Addition of Shims," page 21.)

5. If the clearance is within the specified tolerance range, go to chapter 10.9, "Mounting of the Pump Casing," page 17.

Grinding of Stationary Bushing

1. Remove the pump casing; see chapter 10.8, "Pump Casing Removal," page 15.
2. Take the stationary bushing out of the shaft seal set. The positions of the stationary bushings are shown on the *Sectional Drawing of the Shaft Seal* in the *Order-Related Documents* in the attached documents. The stationary bushings are marked by prick punch marks (indentations); see chapter 10.9.1, "Important Markings," page 18.
3. Grind the stationary bushing down to the required dimension.
4. Mount the pump casing.
(see chapter 10.9, "Mounting of the Pump Casing," page 17.)
5. Measure the clearance again.

Addition of Shims

1. **Warning:** Rotating machine parts. Severe pinching of hands.
► Block the rotors with wooden or plastic wedges.
2. Remove the rotor fasteners and the rotors.
3. Temporarily place the required shims on the shafts in these positions.
4. Install the rotors and the rotor nuts as described in chapter 10.13.1, "Preparation of Pump for Measurement," page 20.
5. Measure the clearance again.

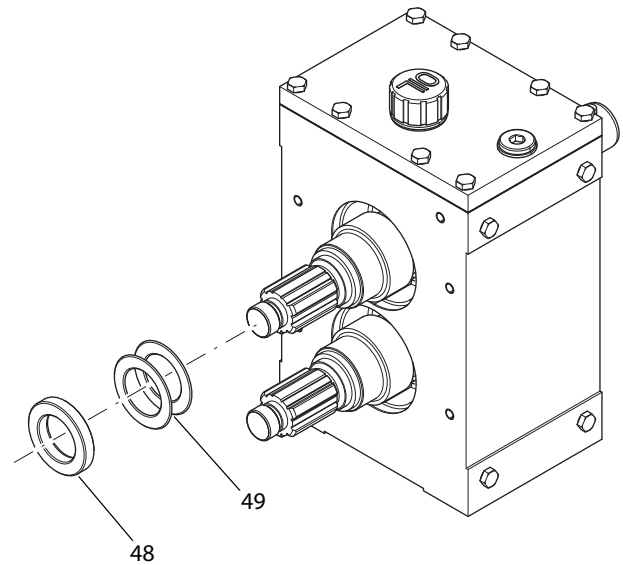

Fig. 25 Addition of shims

6. Clearance correct: Remove the pump casing to place the shims in the correct positions.

(see chapter 10.8, "Pump Casing Removal," page 15.)

7. Place the shims (49) and the stationary bushing (48) on the shaft.
8. Continue as in chapter 10.9, "Mounting of the Pump Casing," page 17 to chapter 10.9.3, "Mounting of the Rotors," page 18.
9. Seal the pump; see chapter 10.9.4, "Pump Sealing," page 19. The clearance measurement is finished.

10.13.3 Measuring radial clearance

- Check your order documents to see whether the pump is equipped with a standard, high-pressure or high-temperature rotor. If necessary, contact Fristam.

Precondition

Pump is prepared for measurement

Procedure

1. Measure the clearance between the rotor and the pump casing with a feeler gauge, see Fig. 26, "Measuring radial clearance," page 22.
2. Compared the measured values with those in the table, see Table 7, "Radial clearance," page 22.

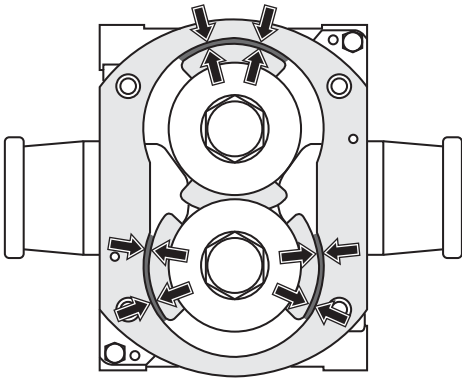

Fig. 26 Measuring radial clearance

Model	Radial clearance [mm]		
	Standard rotor (max. 15 bar)	High-pressure rotor (from 15 bar)	High-temperature rotor
FKL 50	0.05 – 0.07	0.09 – 0.12	0.15 – 0.18
FKL 100	0.10 – 0.14	0.28 – 0.32	0.13 – 0.17
FKL 200	0.10 – 0.15	0.25 – 0.30	0.19 – 0.24
FKL 600	0.32 – 0.38	-	-

Table 7 Radial clearance

11 Appendix 1

11.1 Specifications

11.1.1 Tightening Torques

Tightening Torques for Screws and Nuts

Material: Steel, Strength Class: 8.8

Thread	M8	M10	M12	M16
Tightening Torque [Nm]	25	49	85	210

Material: Stainless Steel, Strength Class: 70

Thread	M8	M10	M12	M16
Tightening Torque [Nm]	17.5	35	62	144

11.1.2 Maximum Discharge Pressures

Pump Size	Maximum Discharge Pressure [bar]
FKL 50	20
FKL 100	20
FKL 200	20
FKL 600	20

Table 8 Maximum discharge pressures

11.1.3 Maximum Medium Temperatures

Rotor Type	Maximum Temperature [°C]
Standard rotors	95
High-temperature rotors	160

Table 9 Maximum temperatures

11.2 Maintenance Intervals

Interval	Model	Maintenance Task	Chapter
Once a day	All	Check the oil level.	See chapter 10.4, "Oil Level Check," page 15.
Once a day	"Sealing and Quenching Liquid" option	Check the sealing or quenching liquid.	See chapter 10.3, "Inspection of Sealing and Quenching Liquid (Optional)," page 14.
2,000 h	All, under severe operating conditions	Change the oil.	See chapter 10.5, "Oil Change," page 15.
4,000 h	All, under normal operating conditions	Change the oil.	See chapter 10.5, "Oil Change," page 15.
When necessary	All	Replace the shaft seal.	See chapter 10.7, "Shaft Seal Replacement," page 15.
When necessary	All	Replace the coupling.	See 10.11 „Coupling Replacement“.
When necessary	All	Replace the motor.	See chapter 10.12, "Gear Motor Replacement," page 19.
According to manufacturer's specifications	All	Lubricate the motor bearings; For additional maintenance intervals for the motor, please see the motor supplier documentation.	See chapter 10.6, "Lubrication of Motor Bearings," page 15.

Table 10 Maintenance intervals

11.3 Troubleshooting Table

Problem	Possible Cause	Remedy
Pump either does not pump or pumps irregularly.	Pump interior not completely filled with liquid; pump interior not vented; discharge valve closed.	Fill pump interior with liquid; open discharge valve.
	Suction line blocked or clogged.	Open or clean suction line.
	Pump with geodesic suction head ¹ : liquid falls at standstill and casing runs dry.	Install foot valve in suction line.
	Suction line leaky; seal on pump cover leaky and drawing in air.	Seal suction line; replace cover seal.
	Air pocket in suction line.	Lay suction line as straight as possible and at steady incline.
	Pump blocked; foreign objects in pump.	Clean pump interior; perform visual inspection; consult <i>Fristam</i> .
	Viscosity of pumping medium too high; medium does not flow well because too viscous.	Consult <i>Fristam</i> .
	Coupling punctured due to overloading.	Consult <i>Fristam</i> .
Flow rate too high.	Pump oversized.	Consult <i>Fristam</i> .
	No regulating valve behind discharge port.	Install regulating valve; add throttle control; reduce motor speed.
Flow rate too low; discharge head too low.	Selected pump too small; motor speed too low due to incorrect voltage.	Consult <i>Fristam</i> ; connect according to motor rating plate.
	Suction line leaky and drawing in air.	Seal leakiness.
	Viscosity of pumping medium too high (too viscous).	Possibly convert to heating; consult <i>Fristam</i> .
	Rotor wear; clearance too large.	Repair.
	Back pressure too high; relief valve (if supplied) regulates incorrectly.	Set relief valve correctly.
	Direction of rotation incorrect.	Correct pipe and electrical connections.
Metal noise.	Foreign objects in pump interior.	Disassemble, inspect, and (if necessary) repair.
	Rotors mechanically catching; rotor nut loose.	Disassemble, rework, and set correct clearance.
	Excessive wear of bearings and gearwheels from overloading or inadequate lubrication.	Disassemble, inspect, and repair. Regular maintenance; lubricant service.
	Speed too high.	Use motor with frequency converter; consult <i>Fristam</i> .
	Pump running dry; shaft seal running dry.	Immediately supply pumping medium; immediately supply sealing water.
	No high-temperature rotors (with larger clearance) installed for pumping medium at elevated temperatures.	Check operating conditions; consult <i>Fristam</i> .
	Excessive throttling of discharge line.	Check operating conditions; consult <i>Fristam</i> .
Flow noise.	Operation in overload or part-load range.	Adjust working point to design.
	Flow losses in suction line too high.	Increase nominal sizes; rule out the possibility of throttling.
	Cavitation.	Check condition for NPSH rating; see <i>chapter 6.5, "Installation of Pipes," page 11</i> . Consult <i>Fristam</i> .
Vibrations	Weight and hydraulic forces of pipes stressing the pump.	Support pipes so that pump is not stressed; install vibration dampers if necessary; keep water hammers away from pump.
Excessive heating of pump shaft bearings and drive gear.	Bearing damage.	Disassemble; replace bearing.
	Lubricating oil inadequate.	Change lubricating oil (see <i>Table 3 on page 15</i>); perform maintenance at regular intervals (see <i>Table 10 on page 23</i>).

Table 11 Troubleshooting table

Problem	Possible Cause	Remedy
Motor power consumption too high.	Resistance in discharge line too high; pump throttled too much; flow rate too low.	Increase nominal size of discharge line; open throttle valve; reduce speed using frequency converter on motor or control gear.
	Viscosity and/or density of pumping medium too high.	Consult <i>Fristam</i> .
	Rotors installed with inadequate clearance contrary to specifications.	Consult <i>Fristam</i> .
	Massive damage to pump shaft bearing or gear motor.	Disassemble and inspect; consult <i>Fristam</i> .
Leakage at shaft seal.	Shaft seal mechanical damage or wear.	Replace mechanical seal and rotary shaft seal (including all secondary seals); possibly convert to different materials; consult <i>Fristam</i> .
	Shaft seal running dry; suction head too high; pumping medium temperature too high.	Decrease geodesic suction head ¹ ; use double shaft seal; consult <i>Fristam</i> .
	Sealing or flushing water pressure too high.	Adjust using throttle valve and pressure gauge.
	Shaft seal materials not chemically resistant to pumping medium; medium temperature too high.	Consult <i>Fristam</i> ; convert to cooling or double shaft seal.
	Sealing or flushing water pressure too low; sealing water tubes clogged; shaft seal crusted or damaged.	Adjust sealing water inlet and outlet; clean sealing water tubes; replace shaft seal.
	Sealing water contaminated or too hot.	Use drinking water-quality water with temperature of max. 70°C.

Table 11 Troubleshooting table

¹The "geodesic suction head" is the vertical distance between the suction-side liquid level and the center of the pump pipe connections.

11.4 Number Key

The general number key refers to the appended "Sectional drawings". The part numbers conform to DIN 24250.

Part Number	Name
101	Pump casing
108	Stage casing
160	Cover
13-1	Back casing panel
13-2	Housing insert
130	Casing part
132	Spacer
135	Wearing bush
154	Intermediate wall
156	Outlet side
18-1	Adjustable leg cap
18-2	Vibration damper
182	Base
21-1	Synchronizing shaft
213	Drive shaft
23-1	Rotor
26-1	Bracket for mechanical seal chamber
230	Impeller
32-1	Angular contact ball bearing
32-2	Cylindrical roller bearing
32-3	Deep groove ball bearing
32-4	Tapered roller bearing
321	Radial ball bearing
322	Radial roller bearing
325	Needle bearing
330	Bearing bracket
331	Bearing block.
341	Drive lantern
344	Bearing support lantern
350	Bearing housing
360	Bearing cap
40-4	Half-length taper grooved pin
400	Flat seal
410	Profile seal
411	Gasket
412	O-ring
421	Rotary shaft seal
422	Felt ring
423	Labyrinth ring
433	Mechanical seal
45-1	Thrust ring
451	Stuffing box housing
454	Stuffing box ring
47-1	Spring with washer
47-2	Mechanical seal chamber
47-3	Wedge seal
47-5	Ring nut
471	Seal cover
472	Rotating seal ring
474	Thrust ring
475	Stationary seal ring
476	Stationary seal ring support

Part Number	Name
477	Mechanical seal spring
478	Spring - right hand
479	Spring - left hand
481	Bellows
482	Bellows support
484	Spring retainer
485	Seal driver
500	Ring
50-1	Split lock washer
50-2	V-ring
50-3.60	Set collar
504	Spacer ring
520	Sleeve
523	Shaft sleeve
524	Shaft protective sleeve
525	Spacer sleeve
54-1	Cover bushing
54-2	Bushing
54-3	Stationary bushing
540	Bushing
543	Spacer bushing
55-1	Serrated lock washer
550	Washer
551	Spacer washer
554	Washer
561	Grooved pin
56-1	Roll pin
56-2	Grooved pin with round head
560	Pin
562	Cylindrical pin
59-2	Dished-type lock washer
59-3	Shrink ring
59-4	Lantern
59-5	Membrane
642	Oil level sight glass
680	Enclosure
68-1	Support plate
68-2	Foam strip
68-3	Bracket for enclosure
68-4	Orifice plate
68-5	CF guard plate
681	Coupling guard
701	Bypass line
710	Pipe
71-1	Connection pipe
715	Hose pipe
722	Flange adapter
723	Flange
724	Blind flange
733	Pipe clamp
751	Valve housing
755	Valve bolt
756	Valve spring

Part Number	Name
759	Valve plate
800	Motor
801	Flange motor
87-1	Gearbox
87-2	Gear cover
87-3	Gear cap
87-4	Gear base
839	Contact
872	Gearwheel
89-1	Filler piece
89-2	Spherical cap frame
89-3	Motor foot
89-4	Handle
89-5	Protective cap
89-6	Wheel
89-8	Flat bar steel
89-9	Motor bracket
89-10	Motor bracket
89-11	Spherical cap base support
892	Base plate
894	Console
897	Guide piece
90-1	Stud bolt
90-3	Tapered pin
90-4	Half-length taper grooved pin
90-5	Eyebolt
900	Screw
901	Hex cap screw
902	Threaded stud
903	Screw plug
904	Set screw
906	Impeller bolt
909	Adjusting screw
91-1	Slotted cheese head screw
913	Bleed screw
914	Socket screw
92-1	Star knob nut, long
92-2	Star knob nut, short
92-3	Cap nut
92-4	Rotor nut
92-5	Forcing screw
92-6	Rotor fastener
92-7	Nut with flange
920	Hex nut
921	Shaft nut
922	Impeller nut
923	Bearing nut
93-1	Snap ring
930	Retainer
931	Retaining washer
932	Snap ring
940	Key
941	Woodruff key

Part Number	Name
950	Spring

11.5 EC Declaration of Conformity

Der Hersteller: FRISTAM Pumpen KG (GmbH&Co.)
Kurt-A.-Körber-Chaussee 55
21033 Hamburg

erklärt hiermit, dass folgendes Produkt (Pumpe mit Motor):

- Kreiselpumpentypen: FP, FPE, FP...V, FPH, FPEH, FPH...V, FSPE, FSP...V, FM, FZ, FC, CF, CFE, FPM, FSM
- Verdrängerpumpentypen: FK, FKL, FL, FL2, FL3
- Pulvermischertyp: PM
- Seriennummer: siehe Deckblatt der Betriebsanleitung

allen einschlägigen Bestimmungen der Richtlinie Maschinen (2006/42/EG) entspricht.

Die Maschine entspricht weiterhin allen Bestimmungen der Richtlinien Elektrische Betriebsmittel (2014/35/EU) und Elektromagnetische Verträglichkeit (2014/30/EU), Verordnung (EG) Nr. 1935/2004 und FDA.

Folgende harmonisierte Normen wurden angewandt:

- DIN EN 809:2012-10: Pumpen und Pumpenaggregate für Flüssigkeiten Allgemeine sicherheitstechnische Anforderungen
- DIN EN ISO 12100:2011-03: Sicherheit von Maschinen - Allgemeine Gestaltungsleitsätze – Risikobeurteilungen und Risikominderung.

Unterlagenbevollmächtigter: Horst Helms
Tel.: +49(0)40 72556-107
Anschrift: siehe Adresse des Herstellers

Hamburg, 20.01.2016



Horst Helms / Leitung Qualitätsmanagement

11.6 EG- Einbauerklärung

Der Hersteller: FRISTAM Pumpen KG (GmbH&Co.)
Kurt-A.-Körber-Chaussee 55
21033 Hamburg

erklärt hiermit, dass es sich bei folgendem Produkt (Pumpe ohne Motor):

- Kreiselpumpentypen: FP, FPE, FP...V, FPH, FPEH, FPH...V, FSPE, FSP...V, FM, FZ, FC, CF, CFE
- Verdrängerpumpentypen: FK, FKL, FL, FL2, FL3
- Pulvermischertyp: PM
- Seriennummer: siehe Deckblatt der Betriebsanleitung

nach der Richtlinie Maschinen (2006/42/EG) Anhang II B um eine unvollständige Maschine handelt.

Die relevanten, grundlegenden Sicherheits- und Gesundheitsschutzanforderungen nach Anhang I der o. a. Richtlinie sind angewandt und eingehalten.

Die unvollständige Maschine entspricht weiterhin allen Bestimmungen der Verordnung (EG) Nr. 1935/2004 und FDA.

Die unvollständige Maschine darf erst dann in Betrieb genommen werden, wenn festgestellt wurde, dass die Maschine, in die die unvollständige Maschine eingebaut werden soll, den Bestimmungen der Richtlinie Maschinen (2006/42/EG) entspricht.

Folgende harmonisierte Normen wurden angewandt:

- DIN EN 809:2012-10: Pumpen und Pumpenaggregate für Flüssigkeiten Allgemeine sicherheitstechnische Anforderungen
- DIN EN ISO 12100:2011-03: Sicherheit von Maschinen - Allgemeine Gestaltungsleitsätze – Risikobeurteilungen und Risikominderung

Der Hersteller verpflichtet sich, die speziellen Unterlagen zur unvollständigen Maschine einzelstaatlichen Stellen auf Verlangen elektronisch zu übermitteln.

Die zur Maschine gehörenden speziellen technischen Unterlagen nach Anhang VII Teil B wurden erstellt.

Unterlagenbevollmächtigter: Horst Helms
Tel.: +49(0)40 72556-107
Anschrift: siehe Adresse des Herstellers

Hamburg, 20.01.2016



Horst Helms / Leitung Qualitätsmanagement

12 Appendix 2 – Assembly Instructions (Optional)

12.1 Safety Instructions

These assembly instructions are addressed solely to specialized employees.

12.2 Scope

These assembly instructions apply to pumps supplied without motors (optional). The pump is initially an incomplete machine.

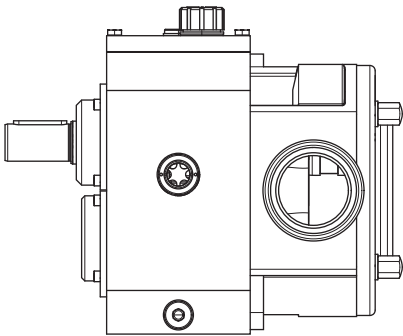

Incomplete machine: pump without motor, coupling, or base frame

The following specifications in the "Original Operator's Manual" for complete machines do not apply in this case:

- chapter 11.5, "EC Declaration of Conformity," page 28,
- chapter 11.1.2, "Maximum Discharge Pressures," page 23,
- chapter 2.5.3, "Rating plate," page 7.

12.3 Rating Plate

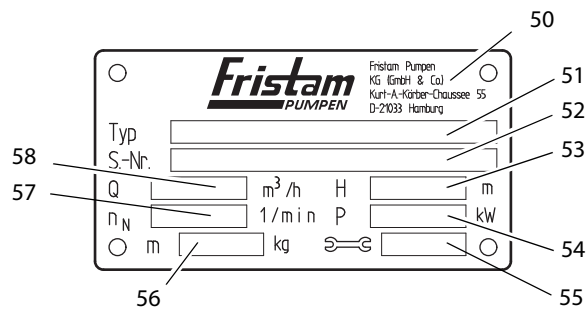

Fig. 27 Rating plate for pump without drive

50	Manufacturer
51	Typ: pump series, pump size, model, version
52	S.-Nr.: serial number of the pump
53	H: discharge head [m]; without drive: no indication
54	P: motor output [kW]; without drive: no indication
55	Year of manufacture
56	m: mass (pump without drive) [kg]
57	n_N : rated speed [1/min]; without drive: no indication
58	Q: flow rate [m^3/h]; without drive: no indication

12.4 Moving Without Motor

Transportation may only be performed by trained personnel.

The pump can be moved using an industrial truck or a crane.

Always move the pump in the installation condition.

12.4.1 Safety Instructions

Falling or Unsecured Parts

Severe crush injuries.

- ▶ Always wear gloves when performing transportation-related work.

Incorrect Positioning of Pump for Transportation

Leakage of caustic, toxic, or contaminating liquids. Personal injury and material damage from contamination.

- ▶ Always move the pump in the installation condition.

Open, Unsealed Pipe Fittings

Material damage from contamination, impact, or moisture in the pump.

- ▶ Remove the pipe fitting covers just prior to connection to the pipes.

12.4.2 Moving With Industrial Trucks

⚠ WARNING

Unsecured Parts

Death from crushing, pinching of extremities, material damage.

- ▶ Before moving the pump secure it to prevent it from tipping over. Secure the pump to the pallet with tie-down straps, or screw the pump to the pallet.

Preparation

- ▶ Ensure that the pump is adequately secured to the pallet, for example, with straps; see fig. 27, "Moving with pallet truck," page 27.

Procedure

1. Pick up the pallet with the forks on the industrial truck.
2. Carefully move the pallet to the designated location and set down.

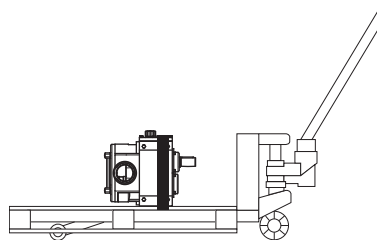

Fig. 28 Moving with pallet truck

12.4.3 Moving With Crane

⚠ WARNING

Falling Parts

Death from crushing, severe pinching of extremities, material damage.

- ▶ Only use suitable means of conveyance and hoists that are designed for the total weight of the pump.

Information on the pump weight can be found on the pump's rating plate as well as in the *Order-Related Documents* in the attached documents.

- ▶ Do not leave the pump in a raised position for longer than necessary.
- ▶ Ensure that the area below the pump is clear of people.

⚠ WARNING

Swinging Parts

Crushing and serious injuries.

- ▶ Start and stop the crane with pump smoothly.
- ▶ Ensure that the danger zone of the pump is clear of people.

Auxiliary Equipment

- Hoists: round slings tested in accordance with DIN EN 1492-1 and 1492-2

Preparation

- ▶ Remove load-securing devices.

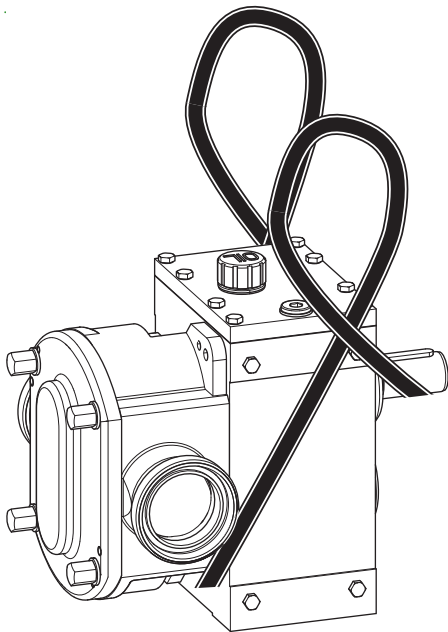

Fig. 29 Moving with round sling

Procedure

1. **Warning:** Round sling damage and tearing. Death from crushing, severe pinching, material damage.

- ▶ Do not lay the round sling over any sharp edges or corners.

Wrap the round sling around the casing and the drive shaft; see fig. 27, "Moving with round sling," page 28.

2. For double shaft seal:

Note: Round sling compresses sealing water tubes. Material damage to double shaft seal.

- ▶ Do not lay the round sling on the sealing water tubes.
3. Cross one sling loop over the other and hook over the hook to ensure that the belt will not slip on the hook.
 4. Position the center of gravity to ensure that the pump is lifted horizontally.
 5. Lift the pump.

12.5 Installation Location

Please see the operator's manual *chapter 6.2, "Installation Location," page 11* for the basic installation location requirements.

12.6 Pump Installation

Prerequisites (Customer-Side)

- Suitable gear motor
- Adequately sized coupling
- Common installation surface for gear motor and pump so that pump shaft can be aligned with gear motor shaft

NOTICE

Incorrectly Designed Motor and Coupling

Destruction of pump and coupling.

- ▶ Only use motors and couplings that have been adapted to the pump characteristic curves. If you have any questions, please contact *Fristam*.

Note: Please see the coupling supplier documentation for reference dimensions for the coupling.

Procedure

1. Mount the coupling parts on the drive shaft and the gear shaft.
2. Place the pump on the base frame or the foundation so that the drive shaft can be connected to the gear shaft with the coupling.
3. Screw the threaded fastener slightly into the pump base.
4. Check the parallel and angular misalignment of the drive and gear shafts.
5. Minimize deviations from the angular and shaft misalignment. If necessary, realign or add shims.
6. Screw the pump and gear to the base frame or the foundation.

7. Fasten the coupling according to the coupling manufacturer's specifications.
8. Install a noncontact, barrier-providing protective device (coupling guard) in accordance with Section 1.4, entitled "Required Characteristics of Guards and Protective Devices," of the Machinery Directive 2006/42/EC.
9. The pump is now installed. Do not commission the pump unless the requirements of the EC Machinery Directive are met for the complete machine.

Note: Continue with *chapter 4, "Transportation," page 9.*

Архангельск (8182)63-90-72
Астана (7172)727-132
Астрахань (8512)99-46-04
Барнаул (3852)73-04-60
Белгород (4722)40-23-64
Брянск (4832)59-03-52
Владивосток (423)249-28-31
Волгоград (844)278-03-48
Вологда (8172)26-41-59
Воронеж (473)204-51-73
Екатеринбург (343)384-55-89
Иваново (4932)77-34-06

Ижевск (3412)26-03-58
Иркутск (395)279-98-46
Казань (843)206-01-48
Калининград (4012)72-03-81
Калуга (4842)92-23-67
Кемерово (3842)65-04-62
Киров (8332)68-02-04
Краснодар (861)203-40-90
Красноярск (391)204-63-61
Курск (4712)77-13-04
Липецк (4742)52-20-81
Киргизия (996)312-96-26-47

Магнитогорск (3519)55-03-13
Москва (495)268-04-70
Мурманск (8152)59-64-93
Набережные Челны (8552)20-53-41
Нижний Новгород (831)429-08-12
Новокузнецк (3843)20-46-81
Новосибирск (383)227-86-73
Омск (3812)21-46-40
Орел (4862)44-53-42
Оренбург (3532)37-68-04
Пенза (8412)22-31-16
Казахстан (772)734-952-31

Пермь (342)205-81-47
Ростов-на-Дону (863)308-18-15
Рязань (4912)46-61-64
Самара (846)206-03-16
Санкт-Петербург (812)309-46-40
Саратов (845)249-38-78
Севастополь (8692)22-31-93
Симферополь (3652)67-13-56
Смоленск (4812)29-41-54
Сочи (862)225-72-31
Ставрополь (8652)20-65-13
Таджикистан (992)427-82-92-69

Сургут (3462)77-98-35
Тверь (4822)63-31-35
Томск (3822)98-41-53
Тула (4872)74-02-29
Тюмень (3452)66-21-18
Ульяновск (8422)24-23-59
Уфа (347)229-48-12
Хабаровск (4212)92-98-04
Челябинск (351)202-03-61
Череповец (8202)49-02-64
Ярославль (4852)69-52-93

<https://fristam.nt-rt.ru/> || fmg@nt-rt.ru