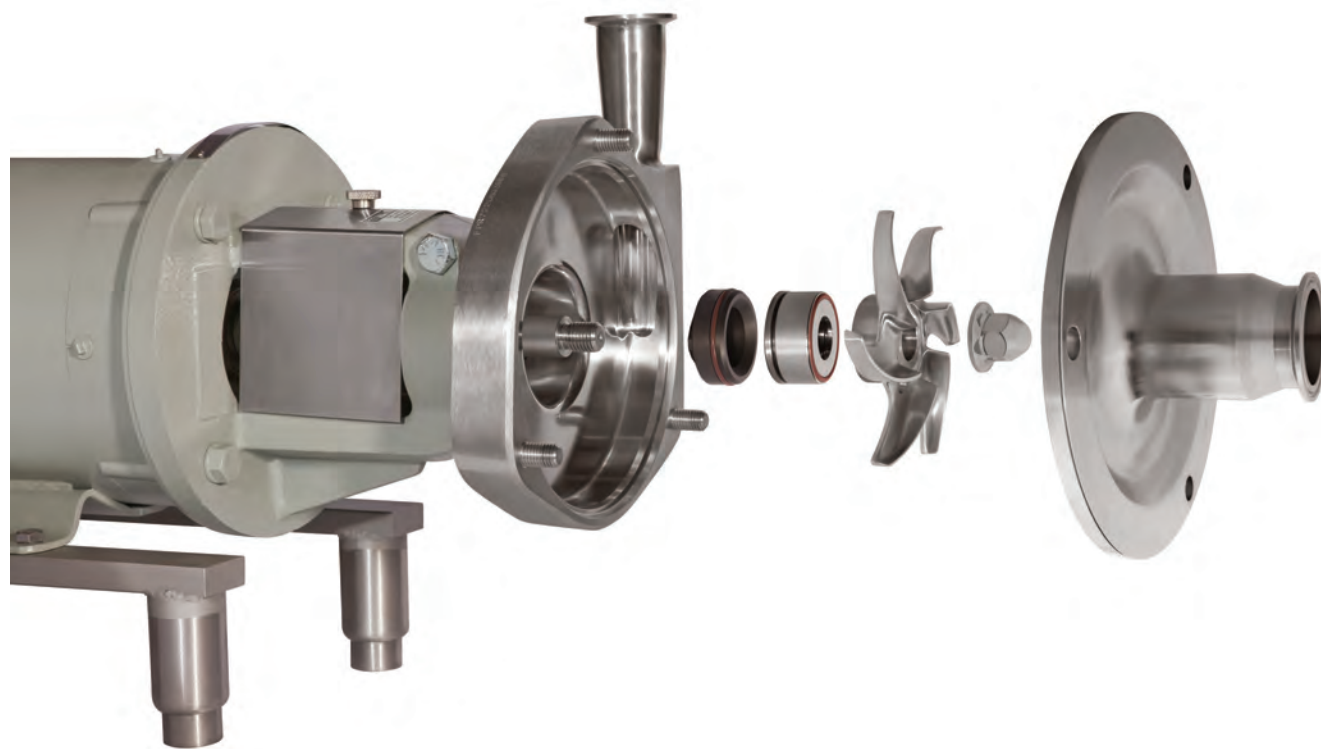


# **Fristam** **PUMPS®**

*Engineered For Lasting Performance®*

## INSTRUCTION AND MAINTENANCE MANUAL: FPR SERIES PUMP



Архангельск (8182)63-90-72  
Астана (7172)727-132  
Астрахань (8512)99-46-04  
Барнаул (3852)73-04-60  
Белгород (4722)40-23-64  
Брянск (4832)59-03-52  
Владивосток (423)249-28-31  
Волгоград (844)278-03-48  
Вологда (8172)26-41-59  
Воронеж (473)204-51-73  
Екатеринбург (343)384-55-89  
Иваново (4932)77-34-06

Ижевск (3412)26-03-58  
Иркутск (395)279-98-46  
Казань (843)206-01-48  
Калининград (4012)72-03-81  
Калуга (4842)92-23-67  
Кемерово (3842)65-04-62  
Киров (8332)68-02-04  
Краснодар (861)203-40-90  
Красноярск (391)204-63-61  
Курск (4712)77-13-04  
Липецк (4742)52-20-81  
Киргизия (996)312-96-26-47

Магнитогорск (3519)55-03-13  
Москва (495)268-04-70  
Мурманск (8152)59-64-93  
Набережные Челны (8552)20-53-41  
Нижний Новгород (831)429-08-12  
Новокузнецк (3843)20-46-81  
Новосибирск (383)227-86-73  
Омск (3812)21-46-40  
Орел (4862)44-53-42  
Оренбург (3532)37-68-04  
Пенза (8412)22-31-16  
Казахстан (772)734-952-31

Пермь (342)205-81-47  
Ростов-на-Дону (863)308-18-15  
Рязань (4912)46-61-64  
Самара (846)206-03-16  
Санкт-Петербург (812)309-46-40  
Саратов (845)249-38-78  
Севастополь (8692)22-31-93  
Симферополь (3652)67-13-56  
Смоленск (4812)29-41-54  
Сочи (862)225-72-31  
Ставрополь (8652)20-65-13  
Таджикистан (992)427-82-92-69

Сургут (3462)77-98-35  
Тверь (4822)63-31-35  
Томск (3822)98-41-53  
Тула (4872)74-02-29  
Тюмень (3452)66-21-18  
Ульяновск (8422)24-23-59  
Уфа (347)229-48-12  
Хабаровск (4212)92-98-04  
Челябинск (351)202-03-61  
Череповец (8202)49-02-64  
Ярославль (4852)69-52-93

# TABLE OF CONTENTS

Technical Information.....4

Preventative Maintenance .....5

Single Seal Assembly Drawing.....6

Double Seal Assembly Drawing.....7

Single/Double Seal Assembly Drawing—FPR 4001 .....8

Exploded Assembly—FPR 700-3540.....10

Exploded Assembly—FPR 3450, 3550, 1051 & 1161 .....12

Exploded Assembly—FPR 4001 .....14

Seal Replacement—All Models (except 4001) .....16

Seal Replacement—FPR 4001 .....22

Pump Shaft Replacement.....25

Setting Impeller to Housing Gap.....27

Motor Replacement .....29

Installation.....30

Maintenance Record.....33

Warranty .....35

## TECHNICAL INFORMATION

### SPECIFICATIONS

Maximum Inlet Pressure.....	150 PSI
Temperature Range .....	-40°F – 400°F
Noise Level.....	60 – 85 dB (A)

### STANDARD MATERIALS OF CONSTRUCTION (NOTE: OTHER OPTIONS AVAILABLE)

Product Contact Components.....	AISI 316L Stainless Steel
Seal Components:	
Rotating Seal .....	Chrome Oxide coated 316L Stainless Steel
Stationary Seal .....	Carbon
Flush Seal (if installed) .....	Ceramic
Product Contact Surface Finish.....	32 in Ra
Flange Support .....	Cast Iron
Gaskets / O-rings .....	Viton
Cover O-ring .....	Buna
Motor .....	NEMA TEFC C-face (Painted Rolled Steel or Painted Cast Iron
.....	3 Phase, 60 Hz, 208-230/460 VAC, 1750/3500 RPM

### FRONT PULL-OUT SEAL OPTIONS

Single Internal Mechanical	
Single Internal Mechanical with Cascade	
Single Internal Mechanical with Double External Mechanical	
Recommended Seal Flush Pressure.....	5 PSI Maximum
Recommended Seal Flush Flow.....	1–2 Gallons per Hour

### SEAL SIZES

757	Used on Models: 700, 710, 720, 3520, 731, 3530, 740, 1740 & 3540 Motor Frame Range: 140TC – 320TC, Single Flange
758	Used on Models: 3450, 3550, 1051 & 1161 Motor Frame Range: 180TC–360TC, Double Flange
102	Used on Model 4001

### SHAFT RUN-OUT TOLERANCE

All models .....	0.05 mm (0.002")
------------------	------------------

### RECOMMENDED TORQUE VALUES

Impeller Nut: Models 700–3550.....	40 ft-lbs
Impeller Nut: Models 1051, 1161, 4001.....	90 ft-lbs
Cover Nut: Model 4001.....	105 ft-lbs
757 Housing Clamp Bolt.....	55 ft-lbs
758 Housing Bolts .....	50 ft-lbs
102 Housing Bolts .....	110 ft-lbs

<i>Motor Size</i>	<i>Motor Bolts</i>	<i>Shaft Collar Screws</i>
56C – 140TC	20 ft-lbs	12 ft-lbs
180TC – 280TSC	55 ft-lbs	24 ft-lbs
280TC – 400TSC	110 ft-lbs	43 ft-lbs*
400TC	110 ft-lbs	105 ft-lbs

*\*Model 4001 with 360TC motor: 105 ft-lbs shaft collar torque*

**IMPELLER GAPS (TO HOUSING/TO COVER)**

700, 710, 720, 731, 740, 1740.....	0.5 mm (0.020”) / 0.5 mm (0.020”)
3530, 3450, 3550, 3540, 1051.....	1 mm (0.040”) / 0.5 mm (0.020”)
3520 .....	0.5 mm (0.020”) / 1 mm (0.040”)
750 .....	1 mm (0.040”) / 1 mm (0.040”)
1161 .....	1.5 mm (0.060”) / 1.5 mm (0.060”)
4001 .....	1.75 mm (0.070”) / 2.25 mm (0.090”)

**TOOLS FOR ASSEMBLY & DISASSEMBLY**

9/16” socket .....	56C – 140TC motor bolts
3/4” socket .....	180TC – 280TC motor bolts, double flange housing bolts
.....	Single flange housing clamp bolt
15/16” socket .....	Impeller nut, 320TC – 360TC motor bolts
24mm socket .....	Cover nut, model 4001
32mm socket .....	Impeller nut, model 4001
3/16” Allen wrench socket.....	56C – 180TC shaft collars
1/4” Allen wrench socket.....	210TC – 250TC shaft collars
5/16” Allen wrench socket.....	280TC – 360TSC shaft collars
3/4” wrench.....	Single flange clamp bolt
Ratchet .....	For loosening bolts
Torque wrench.....	For proper tightening
Adjustable pliers .....	For removing water pipes
Soft-faced hammer .....	For removing cover star nuts
3/8” diameter rod.....	For holding the shaft when tightening & loosening the impeller
Food grade lubricant.....	For lubricating o-rings and gaskets

**RECOMMENDED PREVENTIVE MAINTENANCE**

**RECOMMENDED SEAL MAINTENANCE**

Visually inspect mechanical seal daily for leakage. Replace mechanical seal annually under normal duty. Replace mechanical seal as often as required under heavy duty.

**ELASTOMER INSPECTION**

Inspect all elastomers when performing pump maintenance. We recommend replacing elastomers (o-rings and gaskets) during seal, pump shaft and/or motor replacement. If the impeller nut gasket fails, the threaded hole on the impeller nut and the threads on the end of the shaft will need to be cleaned. A wire brush is recommended for cleaning these threads.

**MOTOR LUBRICATION RECOMMENDATIONS**

Use a high grade ball and roller bearing grease. (See Tables 1-3 for more details.) Please consult the motor manufacturers’ recommendations for lubrication.

*Table 1: Motor Lubrication Intervals for Standard Conditions\**

<b>Frame Size: NEMA (IEC)</b>	<b>3500 RPM</b>	<b>1750 RPM</b>
Up to 210 incl. (132 IEC)	5,500 hrs.	12,000 hrs.
Over 210 to 280 incl. (180 IEC)	3,600 hrs.	9,500 hrs.
Over 280 to 360 incl. (225 IEC)	2,200 hrs.	7,400 hrs.

*\*For severe conditions, multiply interval hours by 0.5; for extreme conditions, multiply interval hours by 0.1*

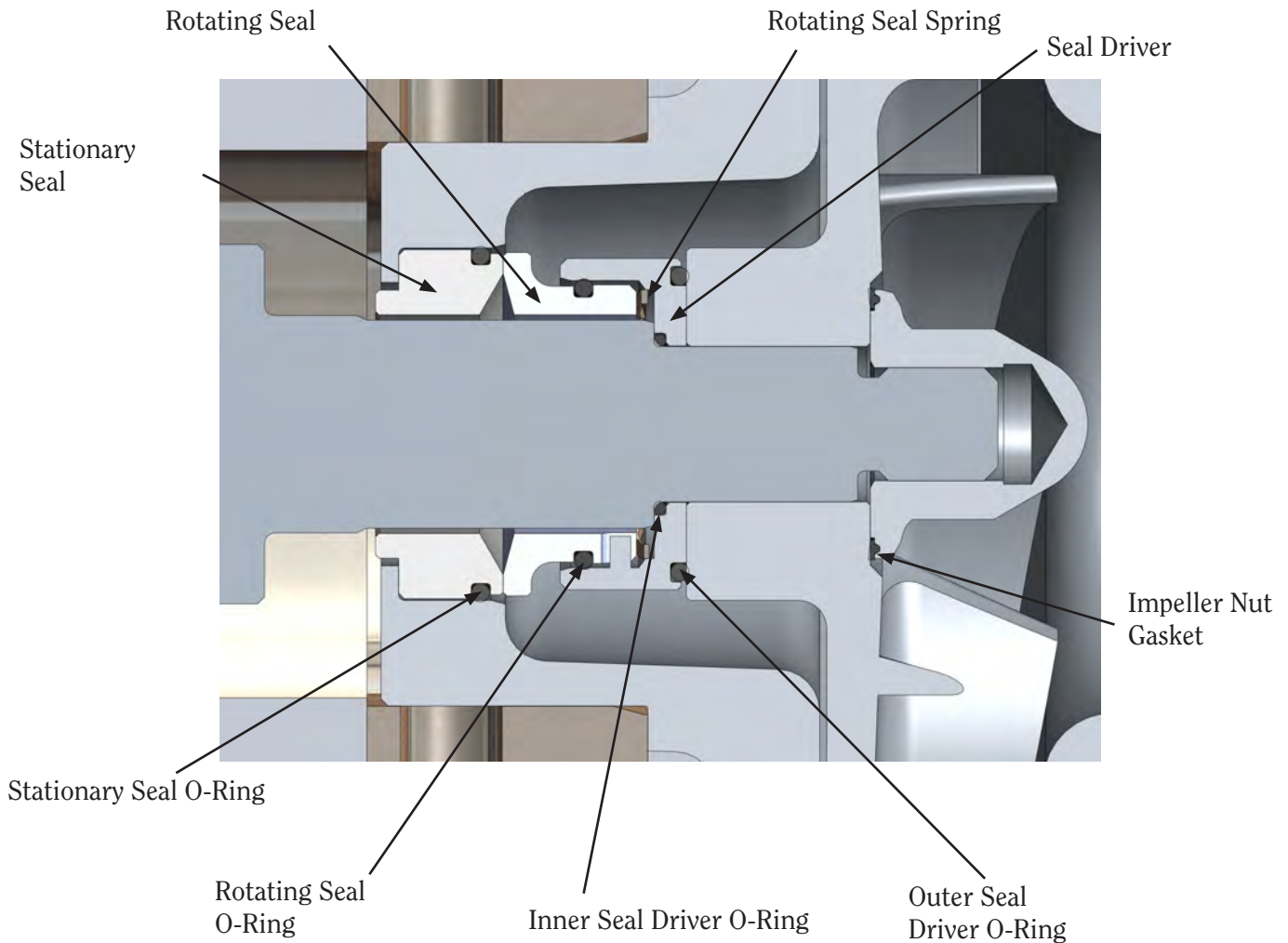
*Table 2: Service Conditions Definitions*

Service Conditions	Max. Ambient Temperature	Atmospheric Contamination
Standard	104°F (40°C)	Clean, little corrosion
Severe	122°F (50°C)	Moderate dirt, corrosion
Extreme	>122°F (50°C)	Severe dirt, abrasive dust, corrosion

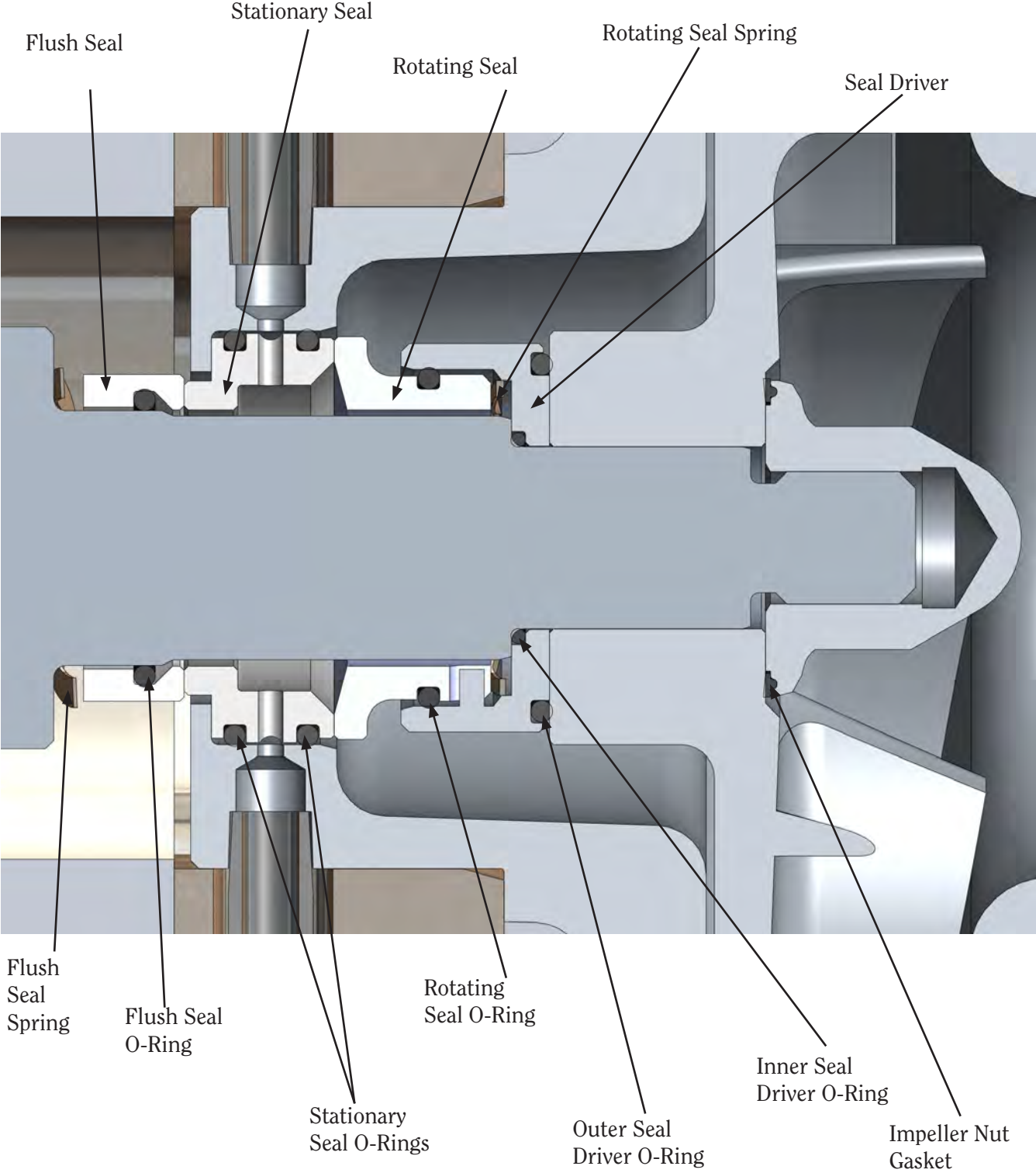
*Table 3: Volume of Grease to be Added per Bearing*

Frame Size NEMA (IEC)	Grease IN <sup>3</sup>	Volume TSP
Up to 210 incl. (132 IEC)	0.6	2.0
Over 210 to 280 incl. (180 IEC)	1.2	3.9
Over 280 to 360 incl. (225 IEC)	1.5	5.2

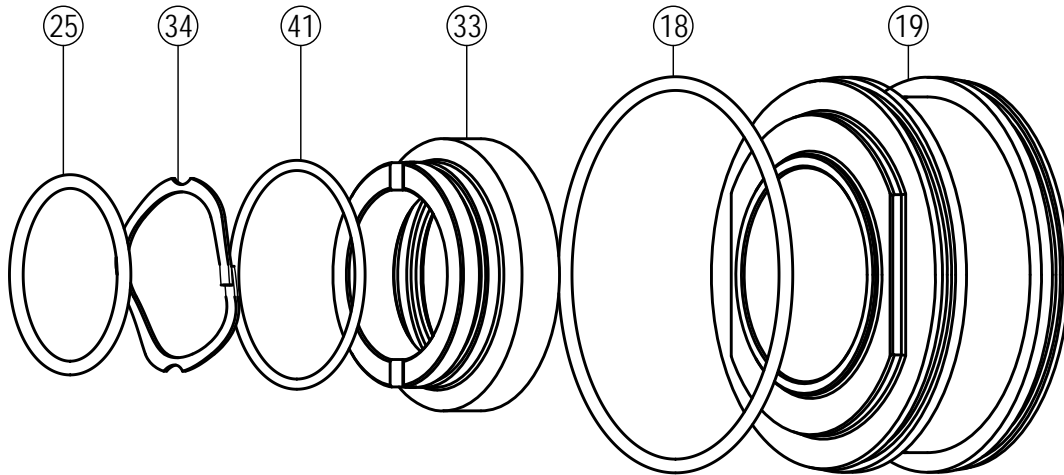
**SINGLE SEAL ASSEMBLY (ALL MODELS EXCEPT 4001)**



DOUBLE SEAL ASSEMBLY (ALL MODELS EXCEPT 4001)

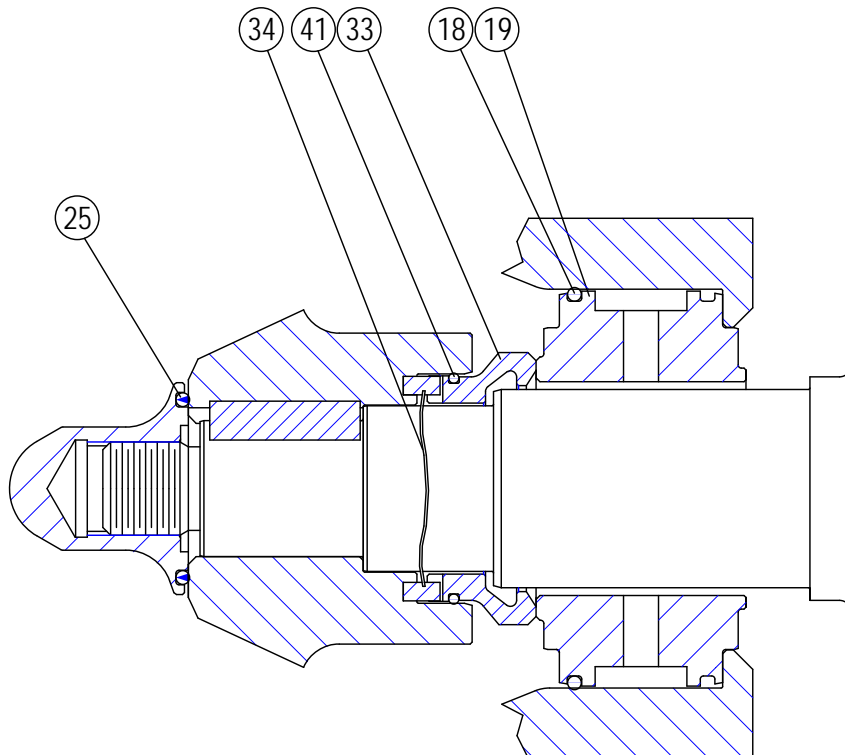


**SINGLE SEAL ASSEMBLY (MODEL 4001)**

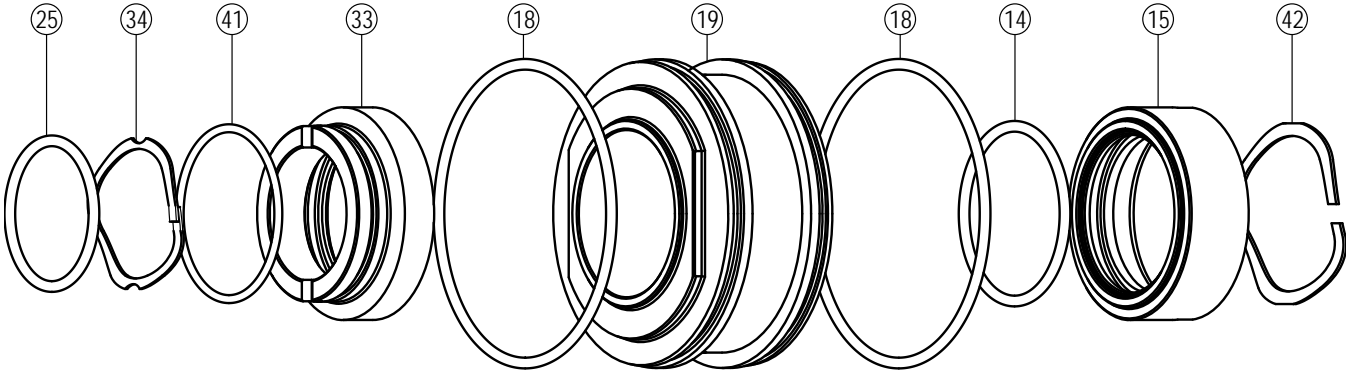


**DESCRIPTION**

- |                         |                           |
|-------------------------|---------------------------|
| ②⑤ IMPELLER NUT O-RING  | ③③ SINGLE ROTATING SEAL   |
| ③④ SINGLE SEAL SPRING   | ①⑧ STATIONARY SEAL O-RING |
| ④① ROTATING SEAL O-RING | ①⑨ STATIONARY SEAL        |

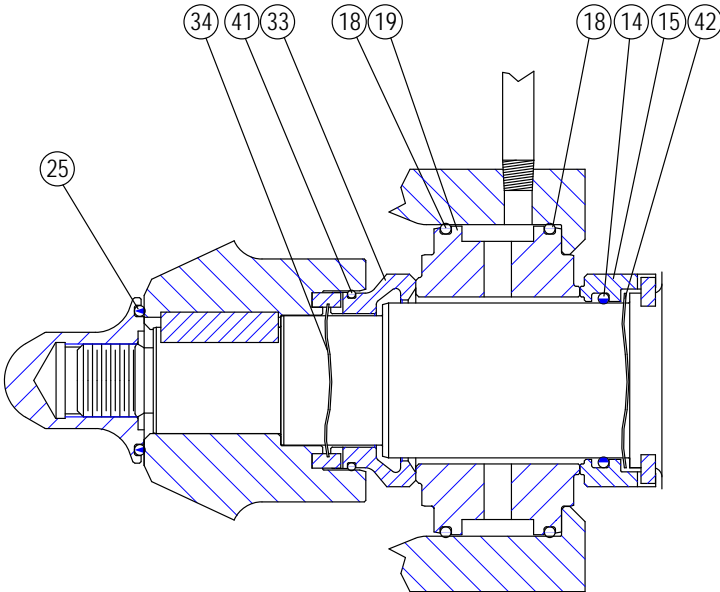


**DOUBLE SEAL ASSEMBLY (MODEL 4001)**

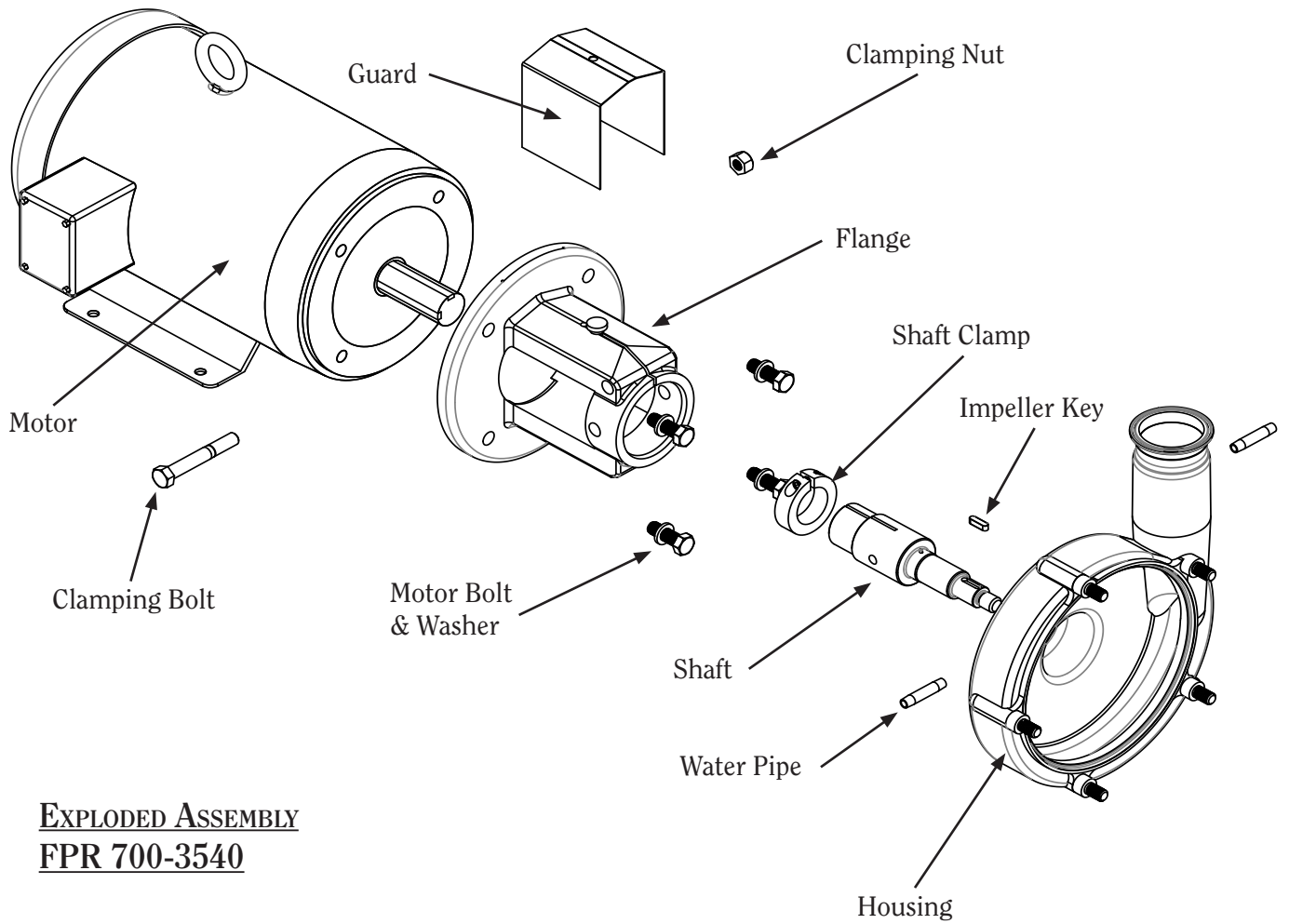


DESCRIPTION

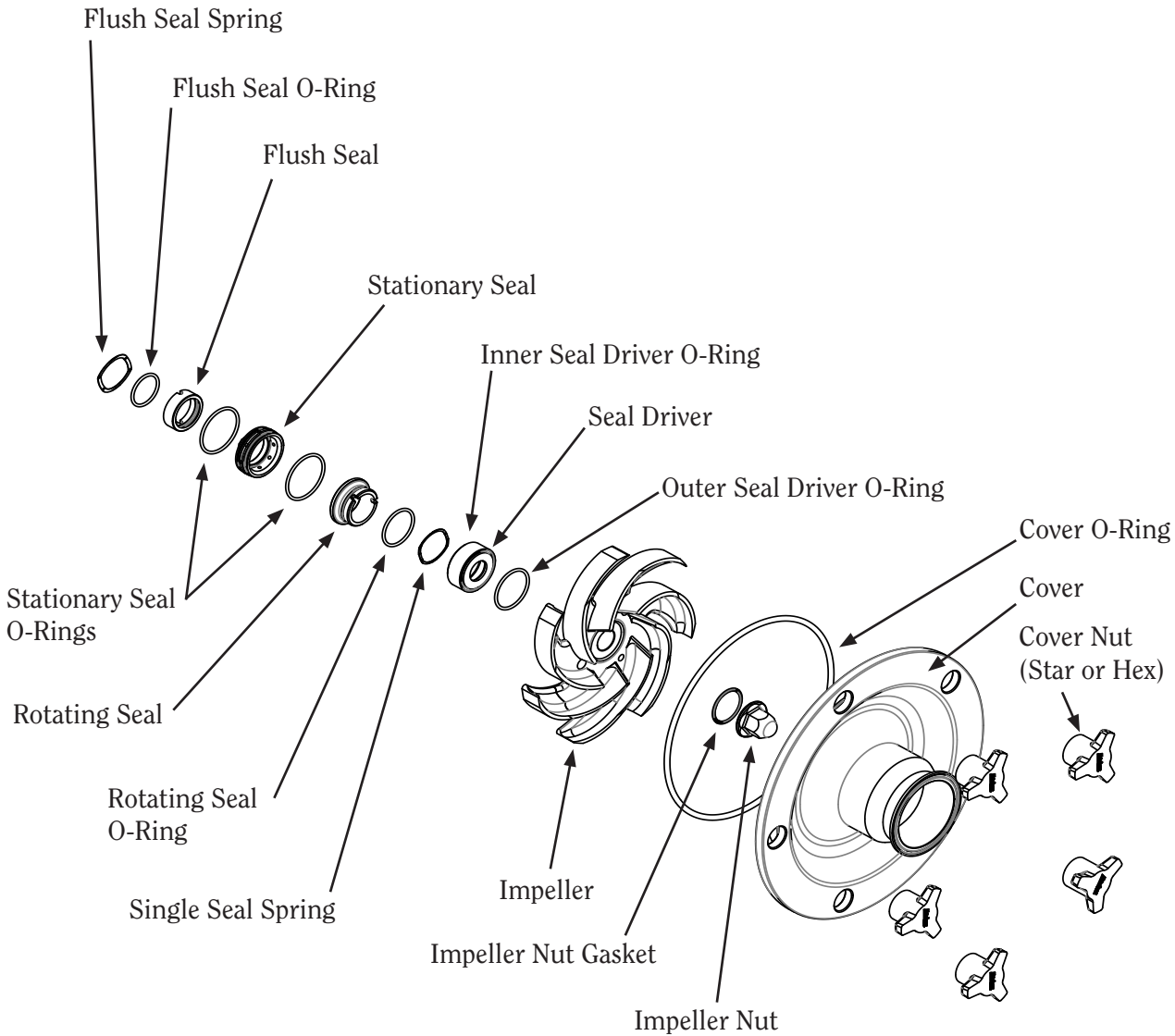
- |                           |                         |
|---------------------------|-------------------------|
| ②5 IMPELLER NUT O-RING    | ①9 STATIONARY SEAL      |
| ③4 SINGLE SEAL SPRING     | ①4 DOUBLE SEAL O-RING   |
| ④1 ROTATING SEAL O-RING   | ①5 DOUBLE ROTATING SEAL |
| ③3 SINGLE ROTATING SEAL   | ④2 DOUBLE SEAL SPRING   |
| ①8 STATIONARY SEAL O-RING |                         |



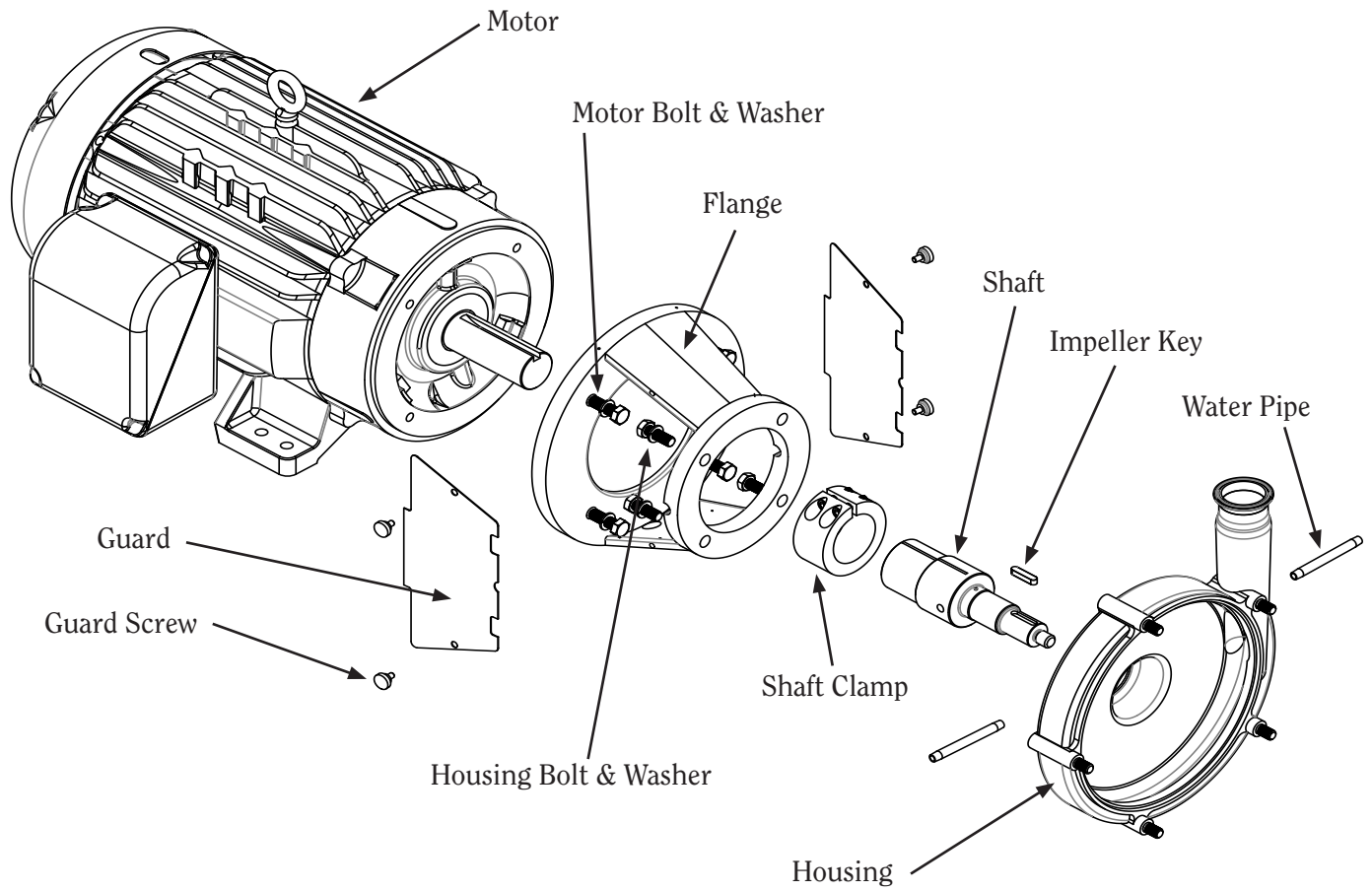




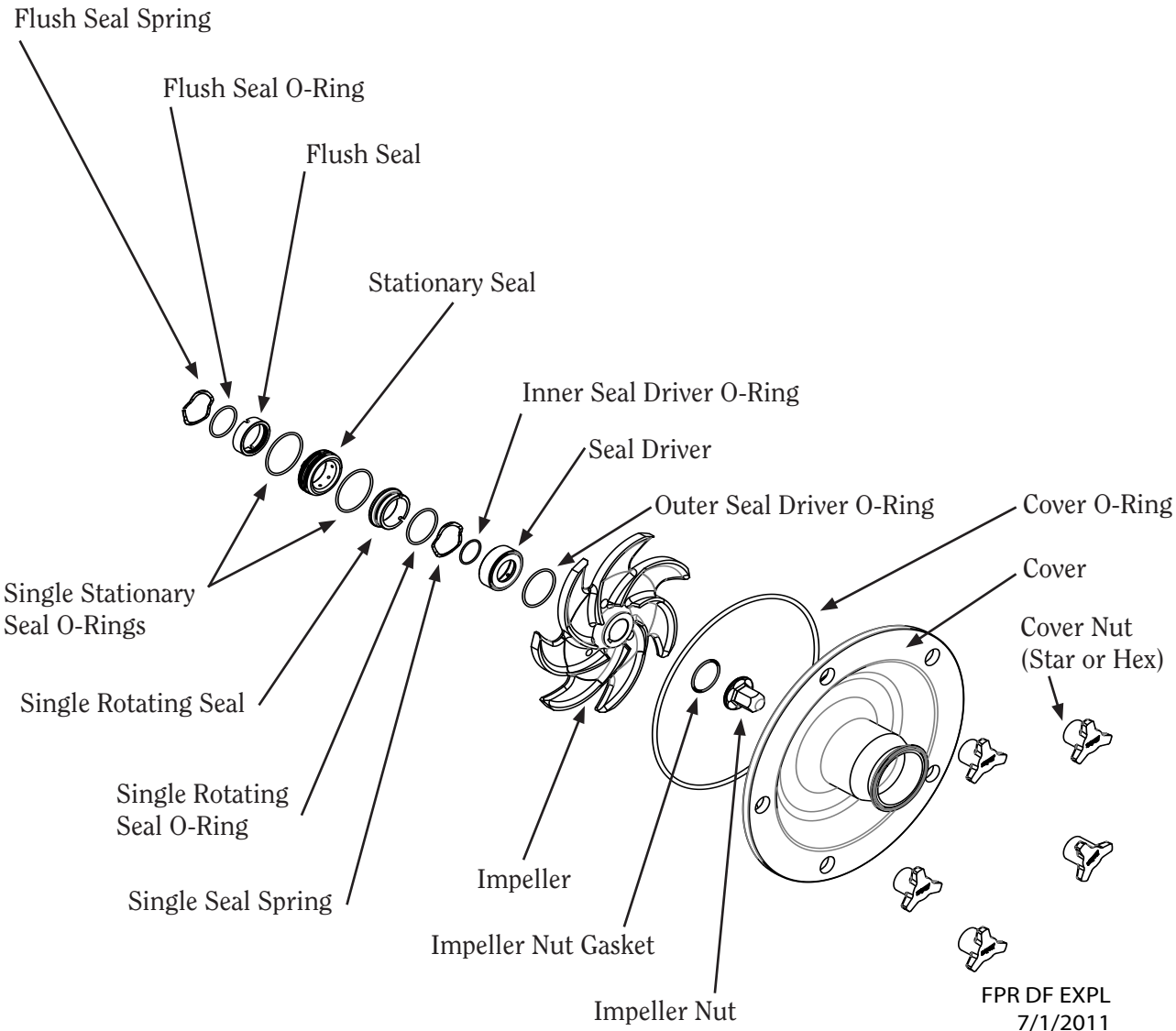
**EXPLODED ASSEMBLY**  
**FPR 700-3540**



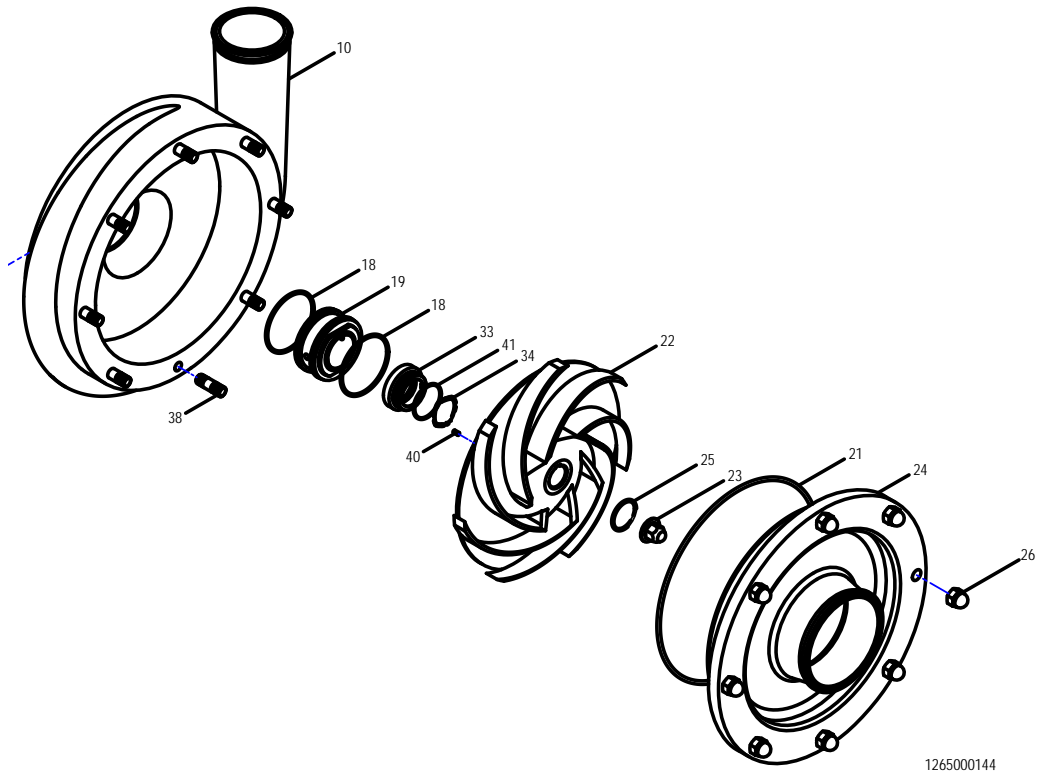
1265000191  
7/1/2011



**EXPLODED ASSEMBLY**  
**FPR 3450, 3550, 1051 & 1161**



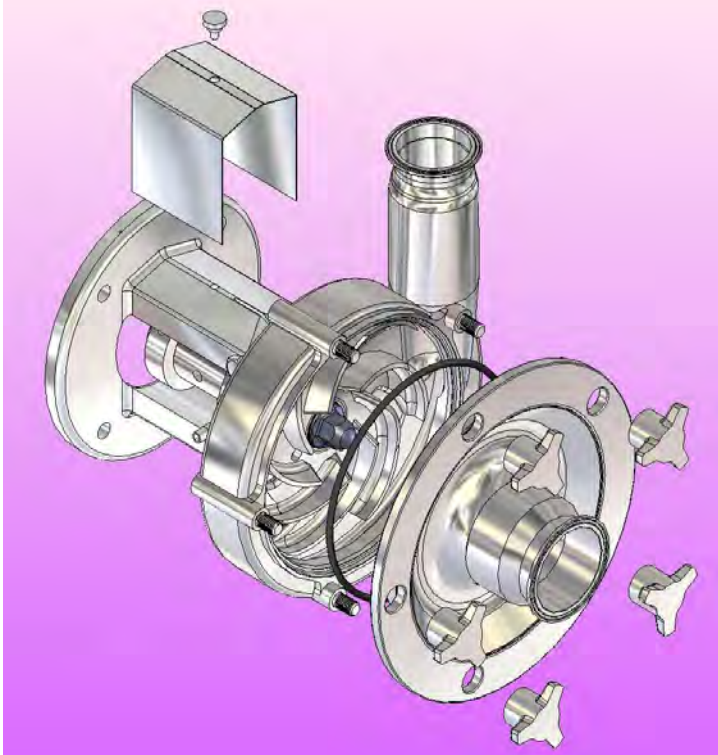




1265000144  
Rev. A

## SEAL REPLACEMENT

### DISASSEMBLY (ALL MODELS EXCEPT 4001)



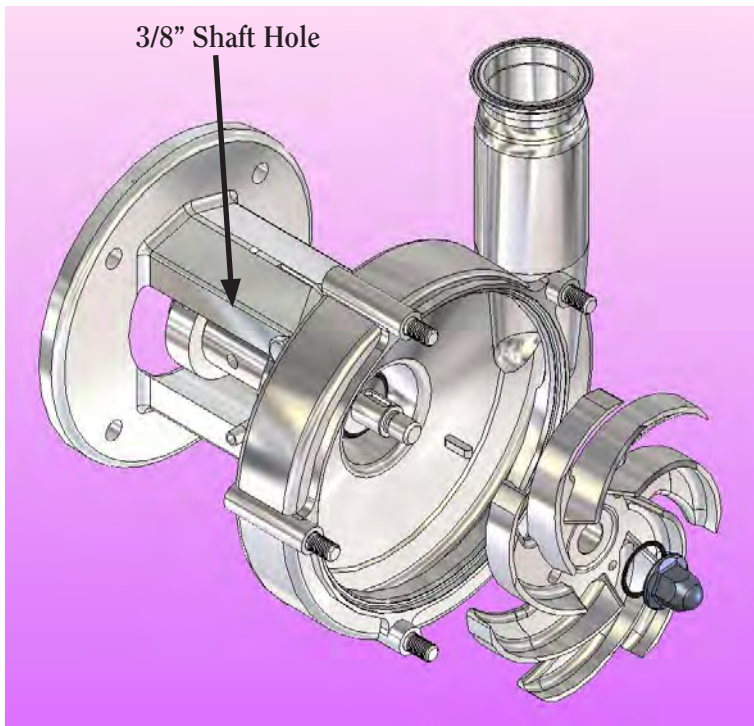
*Note: When replacing ANY seal part, it is important that ALL seal wear parts are replaced to ensure seal integrity.*

*Figure 1*

Remove flange guard.

Remove cover star nuts with soft-faced hammer.

Remove cover and discard cover o-ring.



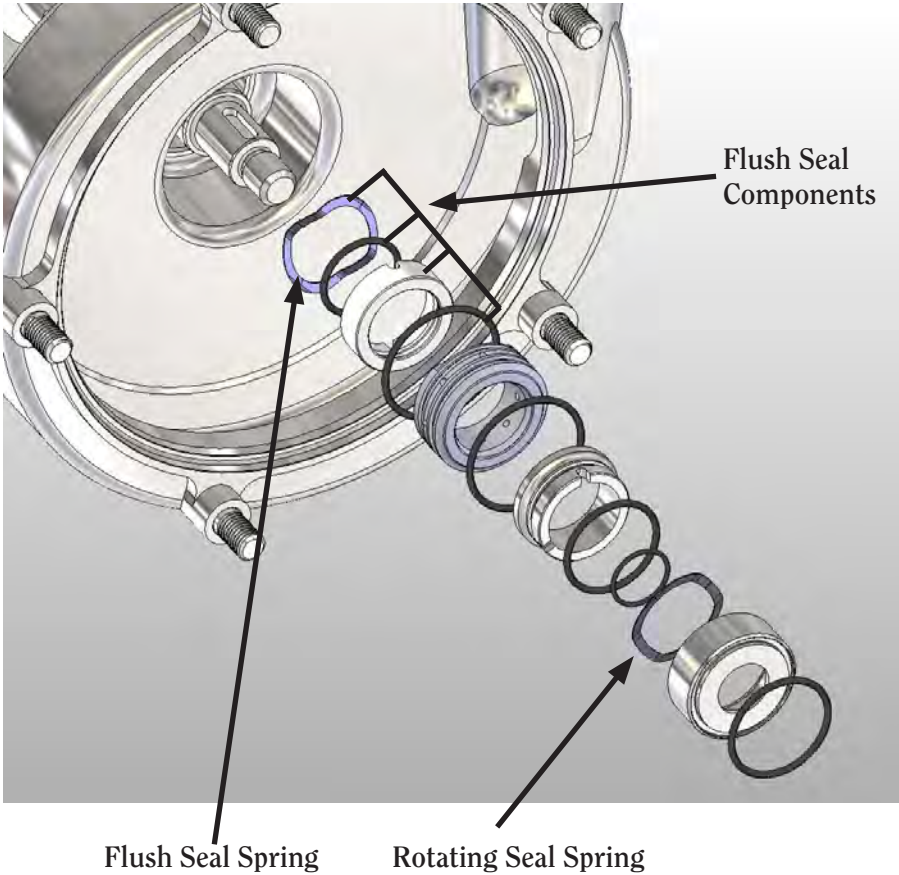
*Figure 2*

Place 3/8" rod or Phillips screwdriver in shaft hole. Use 15/16" socket with ratchet to remove impeller nut. Discard impeller nut gasket.

Remove impeller and discard impeller o-ring.

Remove key.





*Figure 3*

Remove seal driver/rotating seal assembly.

Discard rotating seal, o-rings and spring.

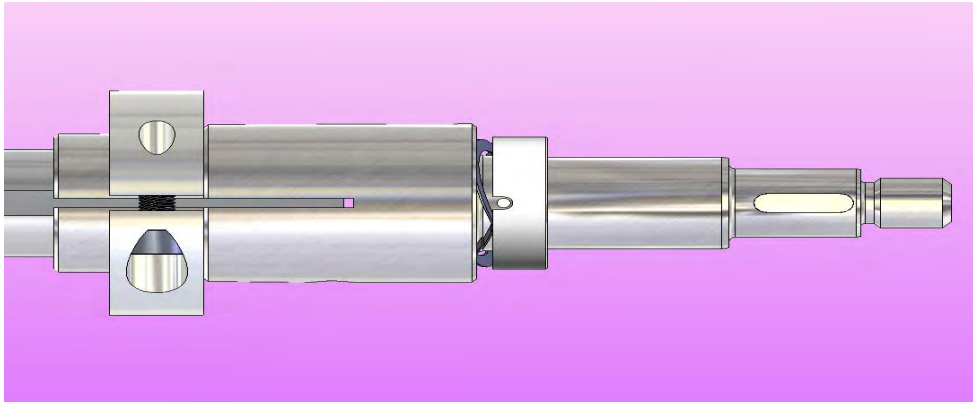
Remove stationary seal and discard.

Double Seal Only: Remove double rotating seal and double spring and discard.

(Note: to distinguish between the seal springs: FLUSH SEAL SPRING HAS A WHITE STRIPE ON THE OUTSIDE EDGE; ROTATING SEAL SPRING DOES NOT

**ASSEMBLY (ALL MODELS EXCEPT 4001)**

Double Seal Only:



*Figure 4*

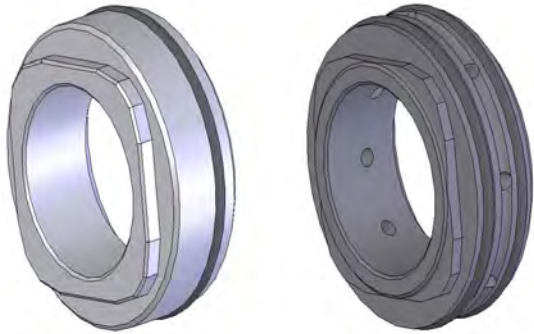
Install spring behind shaft pins. Place o-ring into double rotating seal and lubricate. Push seal onto shaft making sure slots align with pins.

(Note: housing and flange removed from picture for clarity)



Single Stationary  
Seal O-ring

Double Stationary  
Seal O-ring

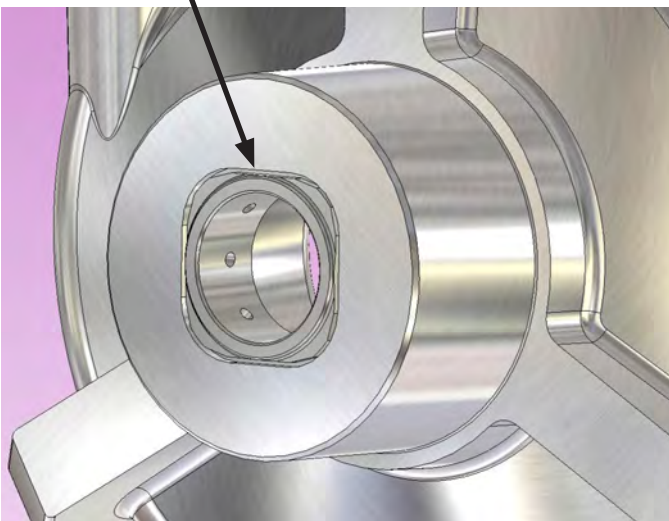


*Figure 5*

Single Seal:  
Install single stationary seal o-ring and lubricate.

Double Seal:  
Install single and double stationary seal o-rings and  
lubricate.

Align flats on  
housing & seal



*Figure 6*

Install the stationary seal into housing making  
sure to align flats on the seal with the flats on the  
housing.



*Figure 7*

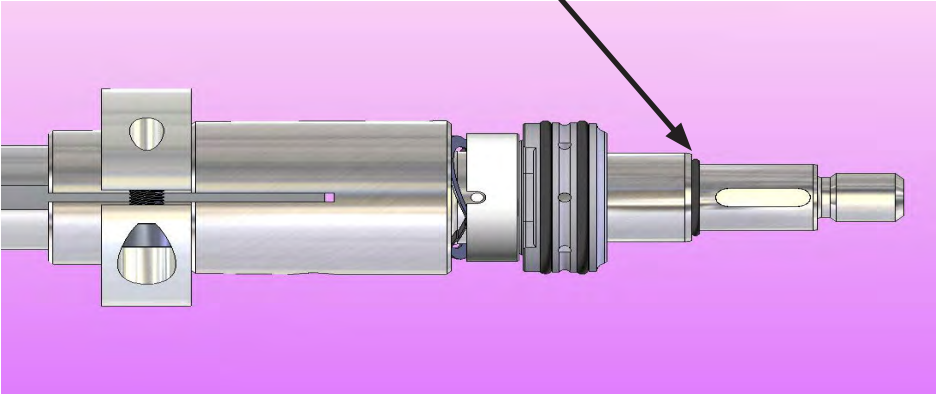
Install spring behind seal pins inside the seal driver.



*Figure 8*

Install single rotating seal o-ring and lubricate. Slide seal driver onto rotating seal making sure to align pins inside the driver with the slots on the seal.

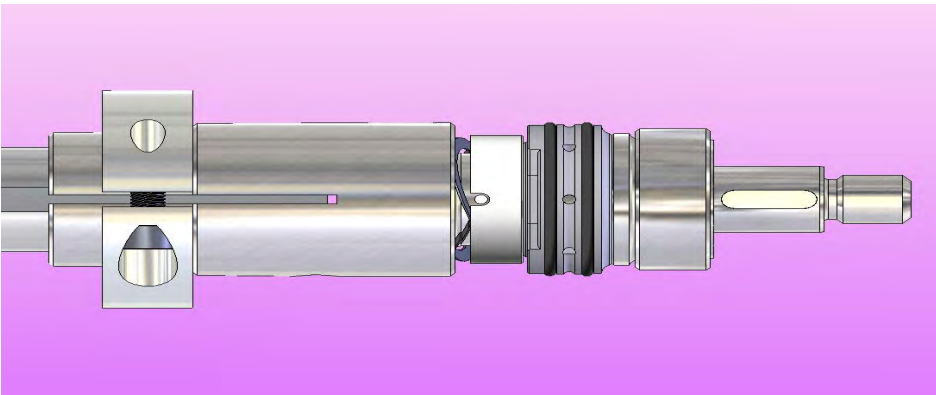
Inner Seal Driver O-ring



*Figure 9*

Slide inner seal driver o-ring onto the shaft and lubricate.

(Note: housing and flange removed from picture for clarity)



*Figure 10*

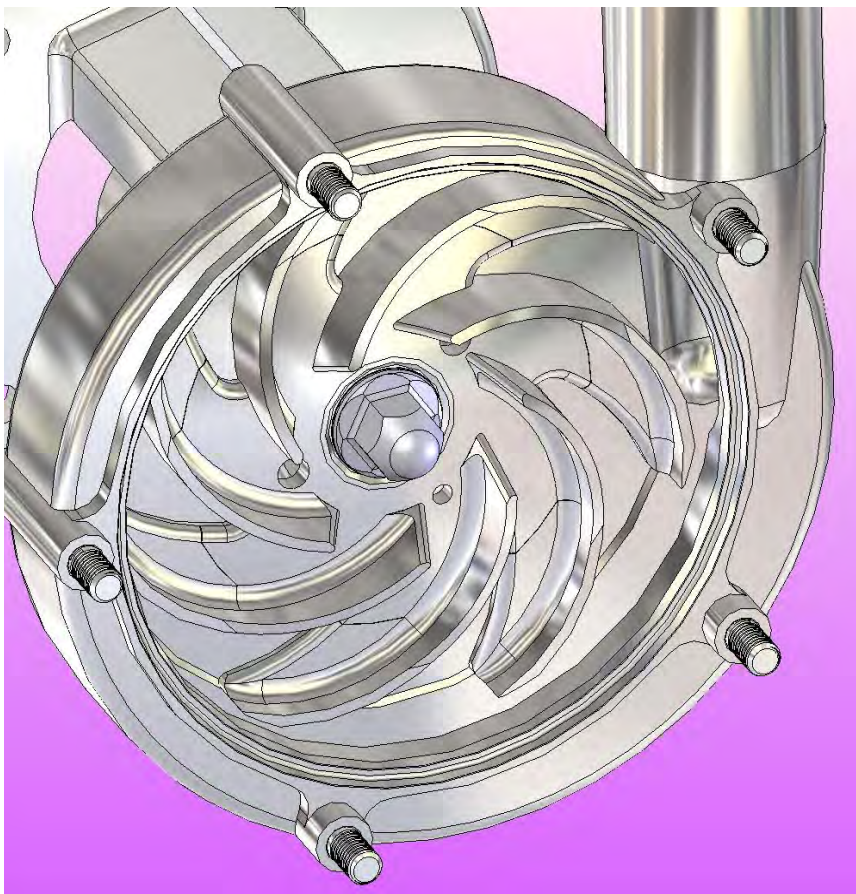
Slide seal driver assembly onto the shaft.

(Note: housing and flange removed from picture for clarity)



*Figure 11*

Install impeller key and outer seal driver o-ring. Lubricate o-ring.



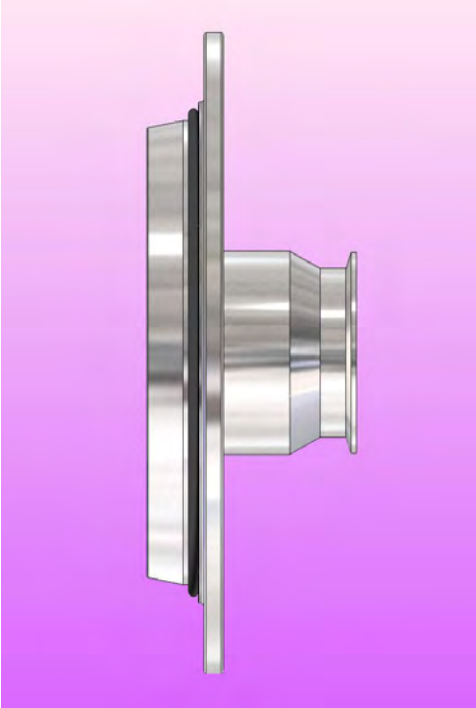
*Figure 12*

Slide impeller onto shaft making sure to align keyway in impeller with key in the shaft.

Lubricate impeller nut gasket and place it onto the impeller nut.

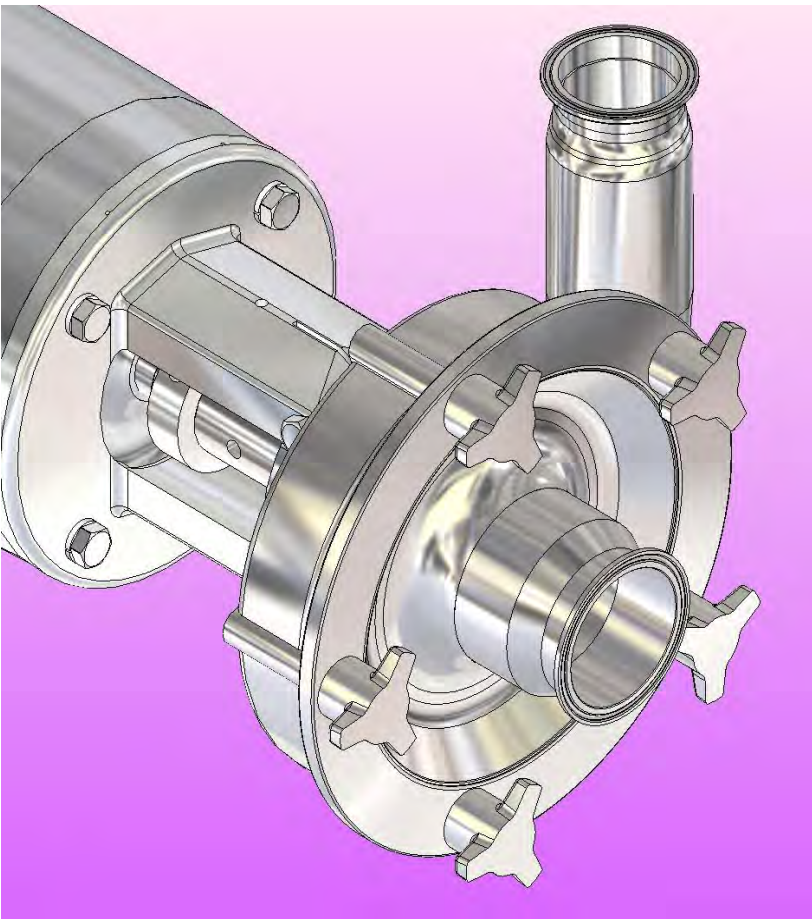
Thread impeller nut onto shaft. Place 3/8" rod or Phillips screwdriver in shaft hole. Use socket with torque wrench and torque nut to proper torque (see page 4).





*Figure 13*

Install cover o-ring.



*Figure 14*

Install cover.

Install cover star nuts and tighten with  
a soft-faced hammer.

## SEAL REPLACEMENT — MODEL 4001

Begin all pump maintenance by disconnecting the energy source to the pump. Observe all lock out/tag out procedures as outlined by ANSI Z244.1-1982 and OSHA 1910.147 to prevent accidental start-up and injury.

*Note: When replacing ANY seal part, it is important that ALL seal wear parts are replaced to ensure seal integrity.*

### TOOLS FOR SEAL REPLACEMENT

Socket wrench  
24mm socket  
32mm socket  
Ratchet  
Pliers (channel locks)  
One soft-faced hammer  
One 5/16" diameter rod  
Optional: One pair impeller pullers (tack pullers)

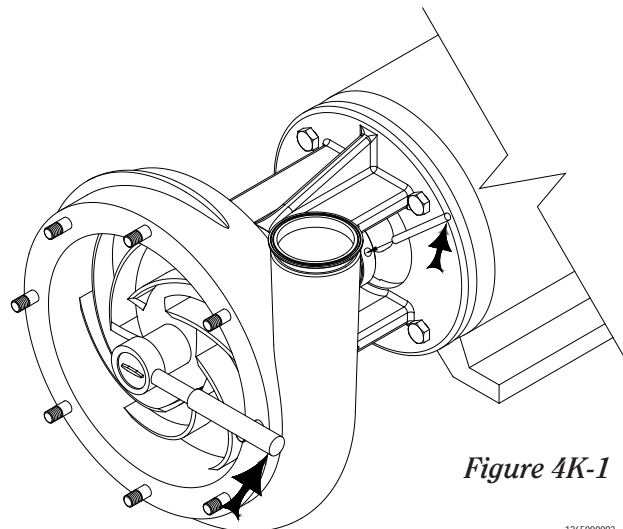
### PUMP HEAD DISASSEMBLY

Note: the reference numbers listed in the text (#) refer to the pump assembly drawing on pages 14-15.

Disconnect the suction pipe from the pump.  
Drain all fluid from the pump prior to disassembly.

- a) Remove the cover nuts (25) with the 24mm socket.
- b) Remove the pump cover (24) and the cover gasket (21).
- c) Remove the guard nuts (3) and remove shaft guards (4).
- d) Place a 5/16" diameter rod in a hole in the shaft (7). Hold the rod to keep the shaft from rotating while loosening the impeller nut (23) with the socket wrench (Figure 4K-1).
- e) Remove the impeller nut and impeller nut gasket (25).
- f) Remove the impeller (22) from the pump shaft (7) by grasping an impeller blade in each hand and pulling the impeller toward you.
- g) After the impeller is removed, place it on a clean flat surface with the blades facing down. The rotating seal is located in hub of the impeller. Remove and discard the rotating seal (33), o-ring (41) and spring (34).
- h) Next remove and discard the stationary seal (19) by pushing on back of seal and sliding it forward out of the housing.

**For Double Mechanical Seals Only** - remove the double rotating seal (15) and spring from the pump shaft and discard.



NOTE: when installing the new seal components make sure that you use all of the components supplied with the replacement seal kit. Using some of the old components may reduce seal life. Lubricate all o-rings with a food grade lubricant, unless otherwise specified in the manual.

**For Double Mechanical Seals Only**

- 1) Generously lubricate the double seal o-ring (14) and install on the double rotating seal (15).
- 2) Install the double seal spring (42) into the back of the double rotating seal.
- 3) Slide the double rotating seal on the pump shaft. Note: Align the grooves in the rotating seal with the pins in the pump shaft. If the seal is installed properly, it will not spin.

**For All Mechanical Seals**

- 4) Generously lubricate both stationary seal o-rings (18) and install. Improper fit may cause leakage or seal damage.
- 5) Slide the stationary seal (19) onto the pump shaft. Align the flat ends of the stationary seal with the flat edges of the housing (Figure 4K-2).
- 6) Lubricate the rotating seal o-ring (41). Install the rotating seal o-ring onto the rotating seal (33).

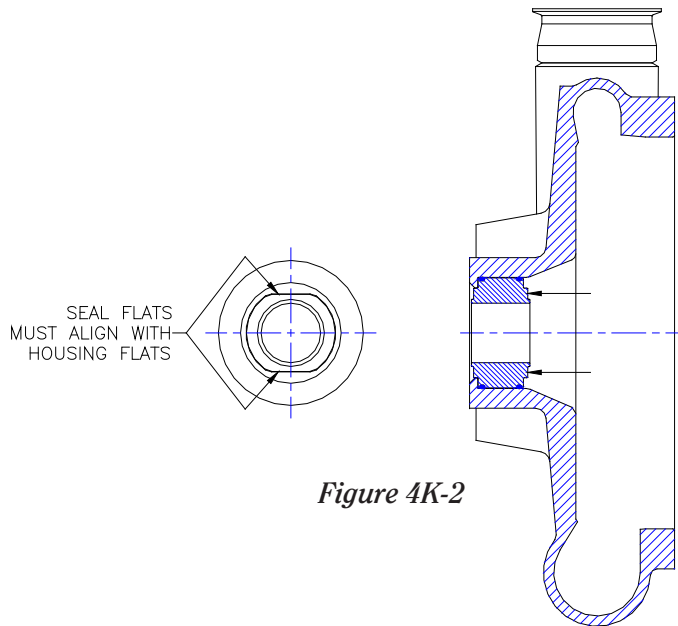


Figure 4K-2

126500013  
4/8/02

- 7) With the impeller, blades on a clean surface, place the single seal spring (34) into the hub of the impeller. Align cuts in spring with pins in the impeller hub.
- 8) Next install the rotating seal into the hub of the impeller (Figure 4K-3). Note: Align the pins in the hub of the impeller with the grooves of the rotating seal. If the seal is installed properly, it will not spin.

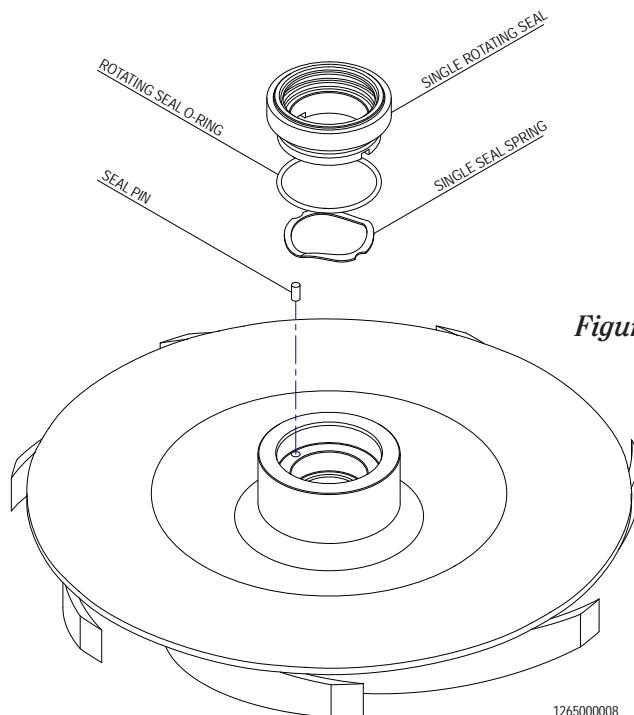


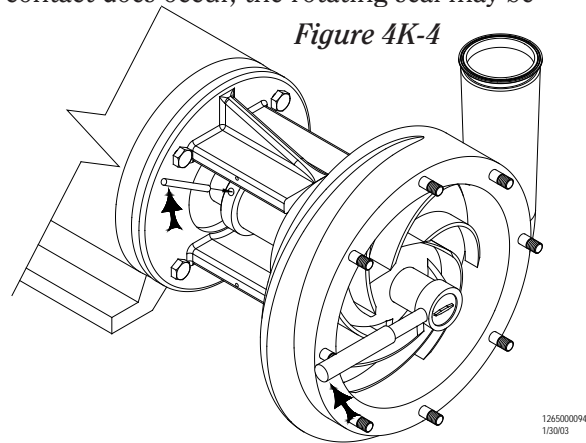
Figure 4K-3

126500008  
Rev. A

9) Now you are ready to install the impeller. First align the shaft key slot on the impeller with the shaft key on the pump shaft. Now carefully install the impeller, making sure that the rotating seal doesn't make contact with the pumps shaft. If contact does occur, the rotating seal may be damaged or dislodged.

10) Lubricate the new impeller nut o-ring (25) and place it onto the impeller nut (23).

11) Thread the impeller nut with the o-ring in place onto the pump shaft (7). Place a 5/16" diameter rod in a hole in the shaft (7). Hold the rod to keep the shaft from rotating while tightening the impeller nut with the socket wrench (Figure 4K-4) using a cross-tightening pattern. Check for the proper torque on page 4.



12) Now install the new cover o-ring (21) onto the pump cover (24) and install them onto the front of the pump. When placing the cover o-ring into the pump cover, gently stretch the o-ring into position. Do not roll the gasket into position.

13) Thread the cover nuts (26) onto the housing studs (238). Make sure the cover o-ring is properly seated in the cover to ensure that it will not get pinched when tightening the cover nuts. Tighten the cover nuts with a 24mm socket (see page 4 for the proper torque).

14) Now rotate the pump shaft (7) to make sure that the impeller (22) moves freely. If it does not, recheck your assembly to make sure that gaskets are not pinched and everything is seated properly. Listen to the pump as you turn the shaft. A small amount of noise from the seals is normal, but if there is metal-to-metal contact, the sound will be noticeable. If there is metal-to-metal contact, check the impeller gap. Re-gap the impeller if necessary (see additional instructions). Replace the shaft guards (4) and secure with the guard nuts (3).

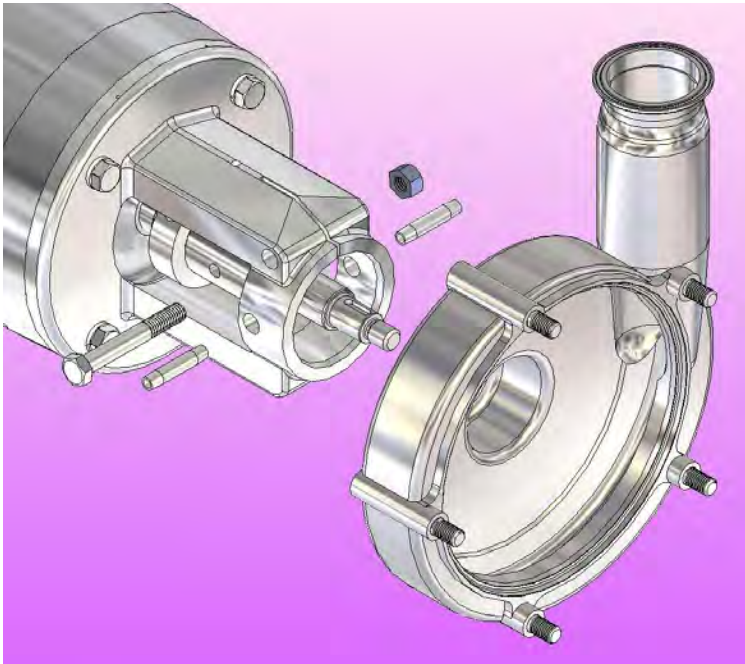
Reconnect the suction piping.

**WARNING:** Mechanical seals must never run dry, even momentarily. Seal damage will result.

## PUMP SHAFT REPLACEMENT

### DISASSEMBLY

Disassemble pump as described in Figures 1-3



*Figure 15 (models 700-3540 only)*

**Double Seal and Water Cascade Only:**  
Remove water pipe(s) using adjustable pliers.

Use two 3/4" wrenches to loosen the clamping bolt and nut. Remove the housing.



*Figure 16 (models 3450, 3550, 1051, 1161, & 4001 only)*

**Double Seal and Water Cascade Only:** Remove water pipe(s) using adjustable pliers.

Use a 3/4" socket to remove the housing bolts and washers. Remove the housing.



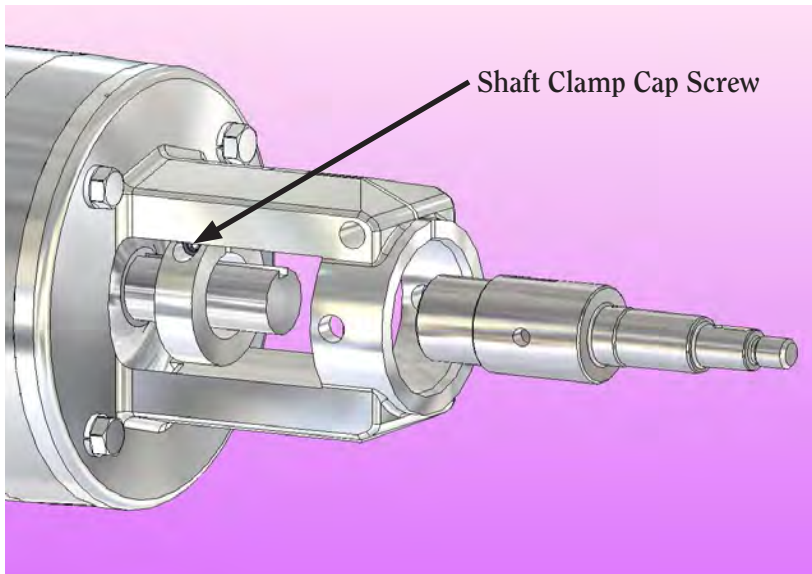
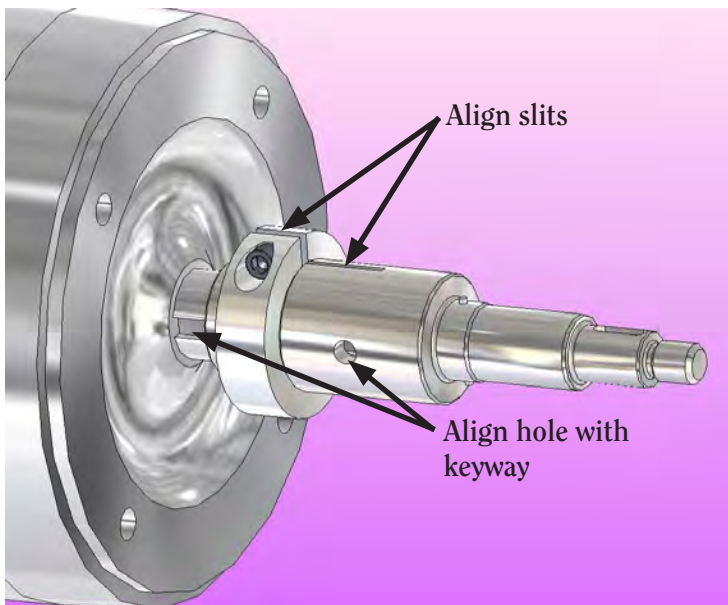


Figure 17

Use an Allen wrench to loosen the shaft clamp cap screw(s). Remove pump shaft.



**ASSEMBLY**

Figure 18

Install new shaft making sure to align the slit in the shaft with the slit in the shaft clamp. Also align the keyway in the motor shaft with the hole in the pump shaft.

(Note: flange removed for clarity)

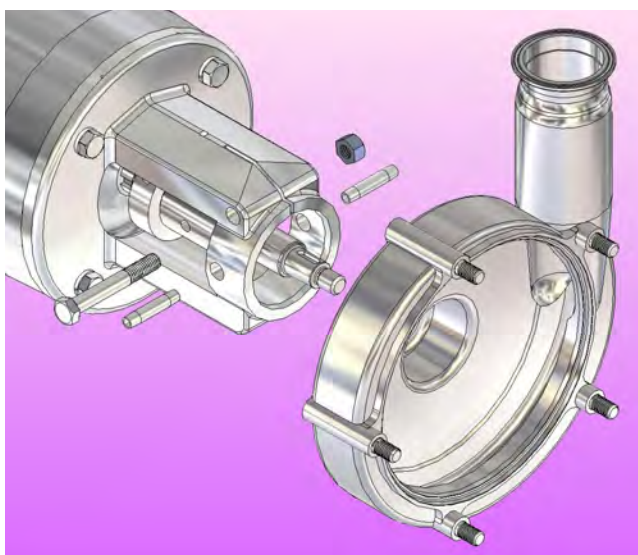
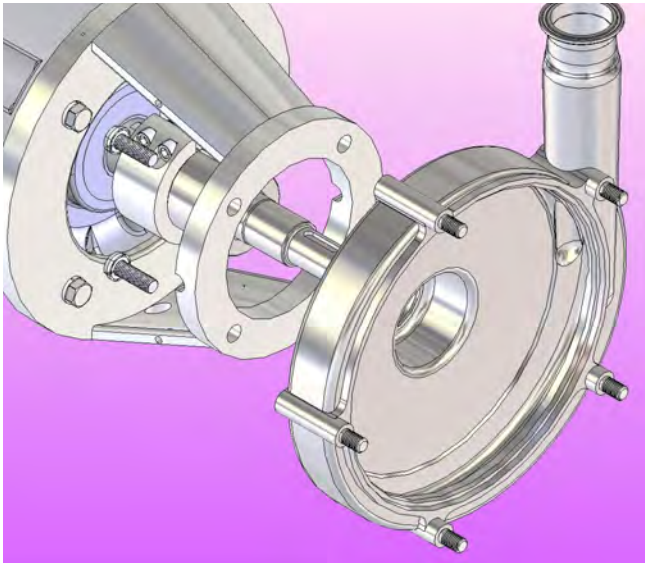


Figure 19 (700-3540 model pumps only)

Install housing hub into the flange. Rotate the housing to align it with the discharge piping.\*

Use a 3/4" wrench and a 3/4" torque wrench to torque the clamping bolt to 55 ft-lbs.

\*Double Seal and Water Cascade Only: Align flush holes in the housing with flush holes in the flange.

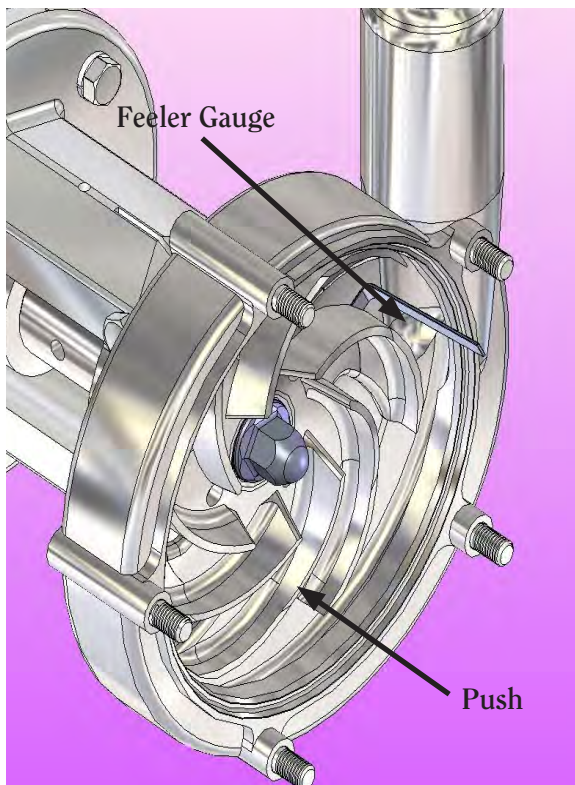


*Figure 20 (models 3450, 3550, 1051, 1161, & 4001 only)*

Install housing hub into the flange. Rotate the housing to align it with the discharge piping and align bolt holes.

Install the lockwashers and bolts. Use a torque wrench to torque the bolts to the proper amount.

## SETTING IMPELLER-TO-HOUSING GAP



*Figure 21-A*

Assemble seal as described earlier.

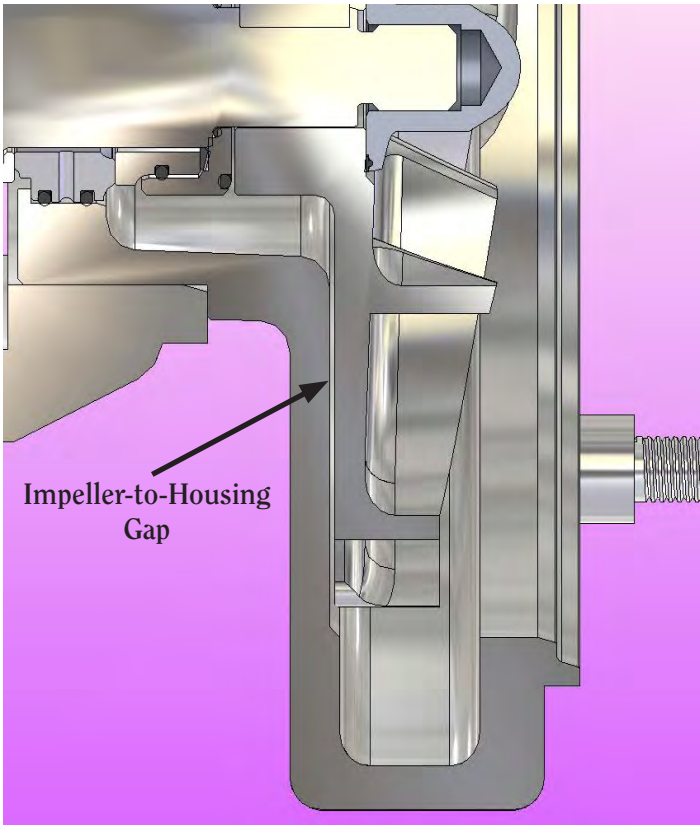
Slide impeller onto shaft making sure to align keyway in impeller with key in the shaft.

Lubricate impeller nut gasket and place it onto the impeller nut. Thread impeller nut with gasket onto pump shaft. Use a torque wrench to tighten the impeller nut to the correct torque value (see page 4).

Slide a feeler gauge between the impeller and housing. The thickness of feeler gauge is determined by the pump model (see page 5 for gauge thicknesses). A plastic feeler gauge may be easier to slide past the lip on the back of the impeller.

Set the impeller-to-housing gap (see figure 21-A) by pushing on the impeller. Once the feeler gauge fits snugly behind the impeller, tighten the shaft clamp bolt with an Allen wrench to the correct torque (see page 4 for torque values).

Remove feeler gauge.



*Figure 21-B*

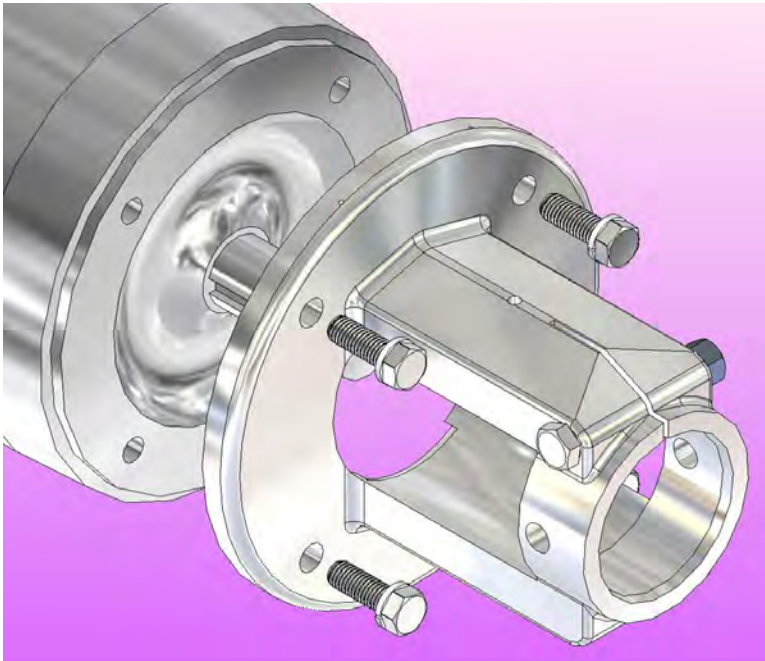
The impeller-to-housing gap is measured between the back of the impeller and the housing.

Install cover o-ring, cover and cover nuts as described earlier.

## MOTOR REPLACEMENT

### DISASSEMBLY

Disassemble pump as described earlier.  
Remove housing and shaft as described earlier.



*Figure 22*

Use a socket to remove the motor bolts and washers. Remove the flange.

### ASSEMBLY

Replace motor. Install flange onto motor. Replace bolts and washers. Use a torque wrench to tighten the bolts to the correct torque (see page 4 for torque values).

Install shaft and housing as described earlier.

Assemble seal as described earlier.

Set impeller-to-housing gap as described earlier.

Install cover o-ring, cover and cover star nuts as described earlier.

Replace guard(s) and water pipe(s) if necessary.



# INSTALLATION

## UNPACKING

Check the contents and all wrapping when unpacking the pump. Inspect the pump carefully for any damage that may have occurred during shipping. Immediately report any damage to the carrier. Remove the shaft guard and rotate the pump shaft by hand to make sure the impeller rotates freely. Keep the protective caps over the pump inlet and outlet in place until you are ready to install the pump.

## INSTALLING

Prior to actually installing the pump, ensure that:

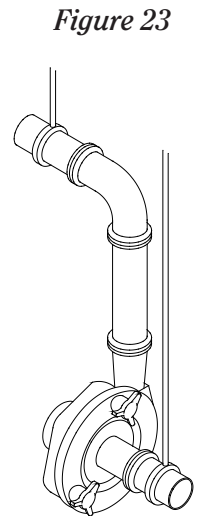
- The pump will be readily accessible for maintenance, inspection and cleaning.
- Adequate ventilation is provided for motor cooling.
- The drive and motor type is suitable for the environment where it is to be operated. Pumps intended for use in hazardous environments (i.e. explosive, corrosive, etc.) must use a motor and drive with the appropriate enclosure characteristics. Failure to use an appropriate motor type may result in serious damage and/or injury.

## PIPING GUIDELINES

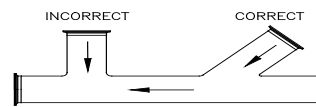
This section describes good piping practices to obtain maximum efficiency and service life from your pump.

Maximum performance and trouble-free operation require adherence to good piping practices.

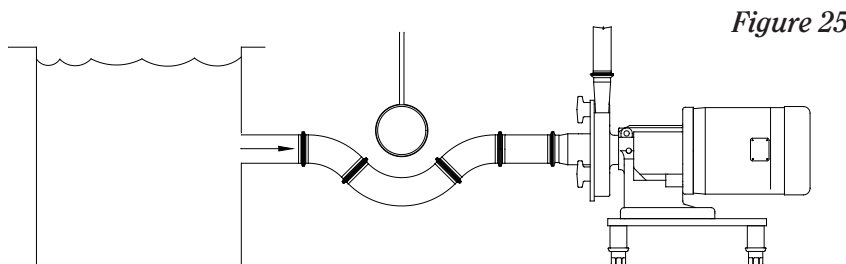
- Ensuring proper piping support and alignment at both the suction inlet and discharge outlet can help prevent serious damage to the pump housing (Figure 23).
- Avoid abrupt transitions in the piping system (Figure 24).
- Avoid throttling valves in the suction piping.
- Keep suction lines as short and direct as possible.
- Ensure that the NPSH available in the system is greater than NPSH required by the pump.
- Avoid sump areas where sediments may collect (Figure 25).



*Figure 23*

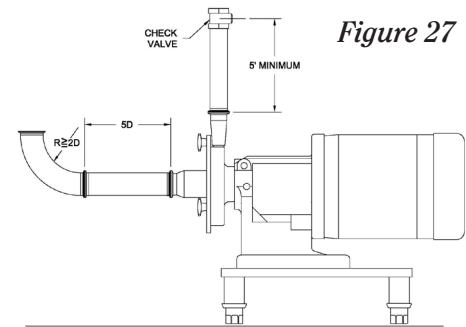
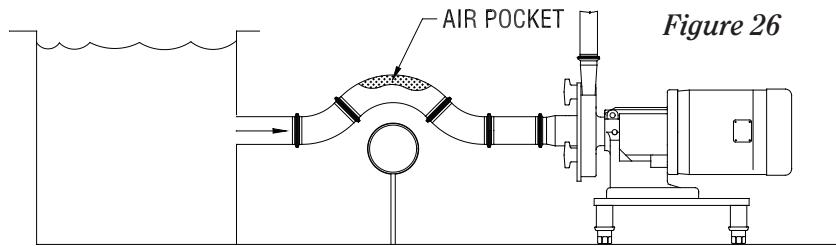


*Figure 24*



*Figure 25*

- Avoid the formation of air pockets in the piping (Figure 26).
- Avoid abrupt closure of shut-off valves, this may cause hydraulic shock which can cause severe damage to the pump and system.
- Avoid elbows in the suction line if possible. When necessary they should be located 5 pipe diameters away from the pump inlet, and have a bend radius greater than 2 pipe diameters (Figure 27).
- Check valves in discharge line should be a minimum of 5 ft. away from the pump outlet (Figure 27).



## ELECTRICAL INSTALLATION

We use standard duty TEFC motors unless otherwise specified. Many motor options are available: washdown, flameproof, explosion proof, hostile duty or chemical duty.

The motor selected should meet the requirements of the specified operating conditions. A change in conditions (for example, higher viscosity, higher specific gravity, lower head losses) can overload the motor. When changing operating conditions or whenever there is any doubt, please contact Fristam Pumps, Inc., for technical assistance.

Have an electrician connect the motor using sound electrical practices. Provide adequate protection. Pumps fitted with mechanical seals must not run dry, not even momentarily. Determine the direction of rotation by watching the motor fan, which must turn clockwise.

## PUMP OPERATIONS

### START-UP INSTRUCTIONS

- Remove any foreign matter that may have entered the pump.
- Do not use the pump to flush the system!
- Check pump for proper rotation as indicated on the pump. **Proper motor direction is clockwise when looking at the fan end of the motor.** (NOTE: When checking the direction of rotation, the pump must be full of liquid.)
- Never run the pump dry, even momentarily. Seal damage can result.

### SHUT-DOWN INSTRUCTIONS

- Shut off the power supply to the pump.
- Close the shut-off valves in the suction and discharge piping.
- Drain and clean the pump.
- Protect the pump against dust, heat, moisture and impact damage.

# INSTALLATION OF WATER FLUSH FOR DOUBLE MECHANICAL SEAL

Set up the water flush for the double mechanical seal as shown (Figure 28). Use only between 1-2 gallons per hour of water at a maximum pressure of 5 PSI. Excessive flow of water through the seal increases the pressure inside the seal. Note: maximum pressure inside the seal is 5 PSI. Excessive flow/pressure through the seal flush will cause excessive wear and shorten seal life.

Pipe the exit side of the water flush with 2-5 feet physical height of tubing. This ensures that some water is always in the center seal and the seal never runs dry.

It is possible to inject steam through the center seal (within the pressure requirements). We do not recommend using steam alone for the cooling/lubricating of the seal.

It is desirable to have the flush water on the outlet side visible. This allows an easy check to see that the flush water is on and also if the seal is functioning properly. In a malfunctioning seal the flush water will disappear, become discolored, or show an unusual increase in flow. If these conditions exist, check the seal and replace if necessary.

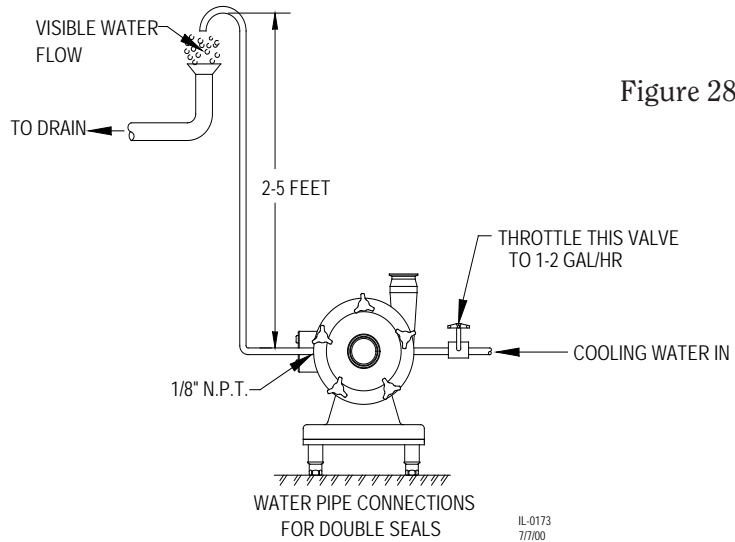


Figure 28

## INSTALLATION OF WATER CASCADE

The water cascade (if supplied) is piped through the hub of the pump housing and into the stationary seal. Since there is no rear seal, the flush water will exit through the rear of the seal area (Figure 29).

Not all FPR pumps require a water cascade on the seal.

Use about 1-2 gallons per hour of water at a maximum pressure inside the seal of 5 psi.

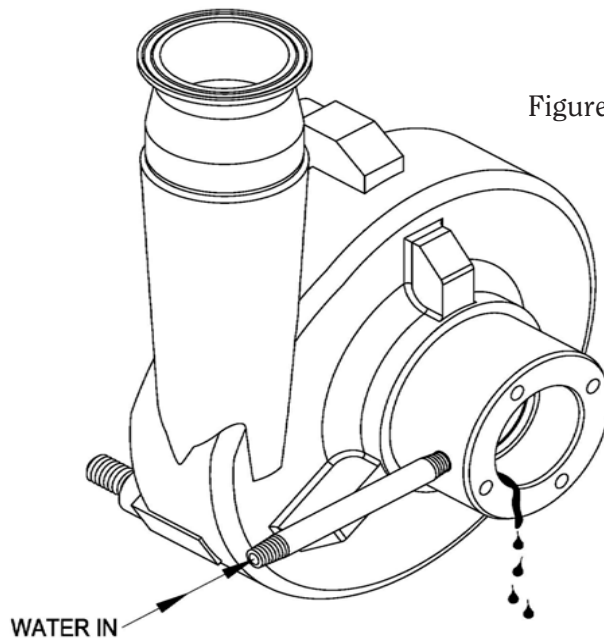


Figure 29

126500062  
8/21/02

Архангельск (8182)63-90-72  
Астана (7172)727-132  
Астрахань (8512)99-46-04  
Барнаул (3852)73-04-60  
Белгород (4722)40-23-64  
Брянск (4832)59-03-52  
Владивосток (423)249-28-31  
Волгоград (844)278-03-48  
Вологда (8172)26-41-59  
Воронеж (473)204-51-73  
Екатеринбург (343)384-55-89  
Иваново (4932)77-34-06

Ижевск (3412)26-03-58  
Иркутск (395)279-98-46  
Казань (843)206-01-48  
Калининград (4012)72-03-81  
Калуга (4842)92-23-67  
Кемерово (3842)65-04-62  
Киров (8332)68-02-04  
Краснодар (861)203-40-90  
Красноярск (391)204-63-61  
Курск (4712)77-13-04  
Липецк (4742)52-20-81  
Киргизия (996)312-96-26-47

Магнитогорск (3519)55-03-13  
Москва (495)268-04-70  
Мурманск (8152)59-64-93  
Набережные Челны (8552)20-53-41  
Нижегород (831)429-08-12  
Новокузнецк (3843)20-46-81  
Новосибирск (383)227-86-73  
Омск (3812)21-46-40  
Орел (4862)44-53-42  
Оренбург (3532)37-68-04  
Пенза (8412)22-31-16  
Казахстан (772)734-952-31

Пермь (342)205-81-47  
Ростов-на-Дону (863)308-18-15  
Рязань (4912)46-61-64  
Самара (846)206-03-16  
Санкт-Петербург (812)309-46-40  
Саратов (845)249-38-78  
Севастополь (8692)22-31-93  
Симферополь (3652)67-13-56  
Смоленск (4812)29-41-54  
Сочи (862)225-72-31  
Ставрополь (8652)20-65-13  
Таджикистан (992)427-82-92-69

Сургут (3462)77-98-35  
Тверь (4822)63-31-35  
Томск (3822)98-41-53  
Тула (4872)74-02-29  
Тюмень (3452)66-21-18  
Ульяновск (8422)24-23-59  
Уфа (347)229-48-12  
Хабаровск (4212)92-98-04  
Челябинск (351)202-03-61  
Череповец (8202)49-02-64  
Ярославль (4852)69-52-93