

Mixing & Blending

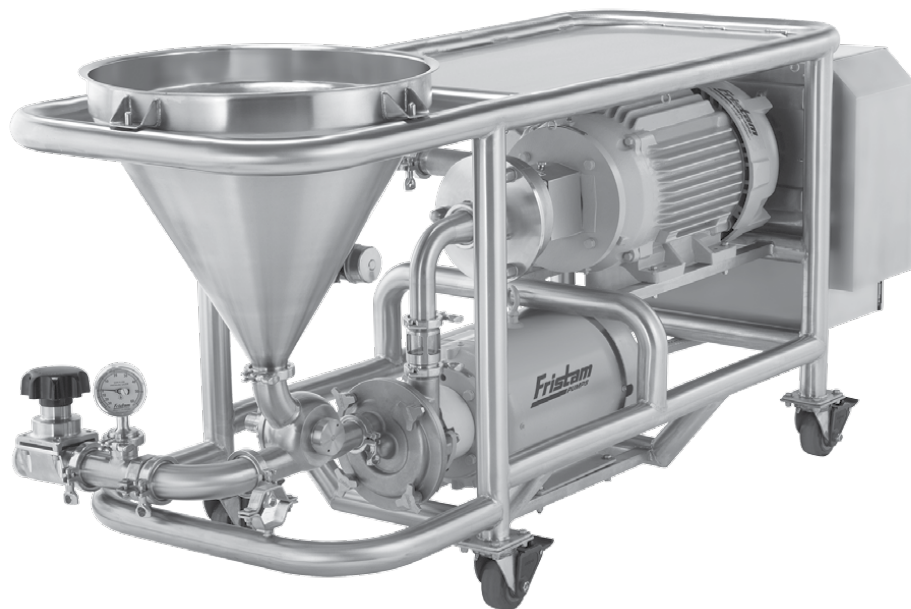

Архангельск (8182)63-90-72
Астана (7172)727-132
Астрахань (8512)99-46-04
Барнаул (3852)73-04-60
Белгород (4722)40-23-64
Брянск (4832)59-03-52
Владивосток (423)249-28-31
Волгоград (844)278-03-48
Вологда (8172)26-41-59
Воронеж (473)204-51-73
Екатеринбург (343)384-55-89
Иваново (4932)77-34-06

Ижевск (3412)26-03-58
Иркутск (395)279-98-46
Казань (843)206-01-48
Калининград (4012)72-03-81
Калуга (4842)92-23-67
Кемерово (3842)65-04-62
Киров (8332)68-02-04
Краснодар (861)203-40-90
Красноярск (391)204-63-61
Курск (4712)77-13-04
Липецк (4742)52-20-81
Киргизия (996)312-96-26-47

Магнитогорск (3519)55-03-13
Москва (495)268-04-70
Мурманск (8152)59-64-93
Набережные Челны (8552)20-53-41
Нижний Новгород (831)429-08-12
Новокузнецк (3843)20-46-81
Новосибирск (383)227-86-73
Омск (3812)21-46-40
Орел (4862)44-53-42
Оренбург (3532)37-68-04
Пенза (8412)22-31-16
Казахстан (772)734-952-31

Пермь (342)205-81-47
Ростов-на-Дону (863)308-18-15
Рязань (4912)46-61-64
Самара (846)206-03-16
Санкт-Петербург (812)309-46-40
Саратов (845)249-38-78
Севастополь (8692)22-31-93
Симферополь (3652)67-13-56
Смоленск (4812)29-41-54
Сочи (862)225-72-31
Ставрополь (8652)20-65-13
Таджикистан (992)427-82-92-69

Сургут (3462)77-98-35
Тверь (4822)63-31-35
Томск (3822)98-41-53
Тула (4872)74-02-29
Тюмень (3452)66-21-18
Ульяновск (8422)24-23-59
Уфа (347)229-48-12
Хабаровск (4212)92-98-04
Челябинск (351)202-03-61
Череповец (8202)49-02-64
Ярославль (4852)69-52-93

In-line Mixing Options

FSI OPTION

Fristam's FSI Series shear pump is an impeller-style version of the Fristam FS Series Shear Blender. A pump and blender in one—for applications requiring both pumping and mixing—Fristam's FSI has an integrated impeller that provides high flow rates while still mixing your product.

TYPICAL APPLICATIONS

- Biodiesel
- Ice cream mix
- Supplemental mixing after a batch tank

FSI SERIES SPECIFICATIONS

- 10 Models
- Max. Tip Speed 145 ft/s (44m/s)
- Max. Flow Rate 375 gpm (1420 lpm)
- Max. Viscosity 30,000 cps





FSH HIGH SHEAR BLENDER

FSH OPTION

The Fristam FSH High Shear Blender is a high-speed version of the FS Series Shear Blender. Designed for emulsifications and particle size reduction applications, the FSH can achieve submicron droplet sizes at one-third the cost of similar technology. Based on Fristam's decades of engineering and manufacturing experience, the FSH provides intense shearing of products with dispersed/emulsified oils.

TYPICAL APPLICATIONS

- Beverages
- Mayonnaise
- Salad dressing

FSH SERIES SPECIFICATIONS

- Max. tip speed 180 ft/s (55 m/s)
- Max. Flow Rate 80 gpm (300 lpm)
- Max. Shear Rate 100,000 1/s

Full Mixing System

Fristam's Powder Mixer blends dry and wet ingredients into a fluid stream and maintains performance even as product viscosity increases.

INTEGRATED SYSTEM

Fristam's Powder Mixer incorporates the uniform powder induction of the FZX liquid ring pump and thorough blending of the FS Shear Blender into a single, compact system.

CONSISTENT POWDER INDUCTION

The FZX is unparalleled as a self-priming pump, easily pulling liquids and solids together.

The table's full-port valve inducts powders fully, eliminates powder bridging and ensures maximum powder induction rate. Vacuum gauges monitor suction for repeatable results.

BLENDS BETTER

Using an intermeshed rotor/stator system, tight gaps at high speeds and high turbulence the Powder Mixer achieves a complete and consistent mix, time after time.

PROCESSES LARGER BATCHES

Since the Fristam Powder Mixer is an in-line system, the batch size is infinite.

BLENDS IN MINUTES

Powders can be wetted and dispersed on the first pass through the Powder Mixer, dramatically reducing process times.

TYPICAL APPLICATIONS

Dairy

- Flavored milk
- Eggnog
- Ice cream mix
- Light & low fat sour cream

Beverage

- Soda syrups & concentrate
- Sucrose solution
- Green tea

Food

- Hummus
- Salsa & hot sauce
- Fruit puree

Personal Care

- Shampoo & conditioner
- Sanitizer gel

Bio-pharm

- Media prep
- Buffer solution
- Glucose

Industrial

- Paintballs





PORTABLE

Smaller models are portable, with locking wheels. The Powder Mixer can be moved easily to different processes as needed.

ERGONOMIC & SAFE

The Powder Mixer operates at floor-level, eliminating dangerous ladder climbing or accidental falling or dropping of equipment from mezzanines. Also, with its waist-height funnel top, there is no bending to pour.

WHY IT'S BETTER THAN BATCH MIXERS

- Devours lumps and clumps
- Blends in minutes
- Processes larger batches

WHY IT'S BETTER THAN FUNNEL/PUMP COMBINATIONS

- High-intensity blending
- Repeatable product consistency

NO RISK TRIAL

Fristam offers on-site trials with your product. For only a nominal fee, Fristam will put our powder mixer to work for you, so you can see the amazing results for yourself.

- Fully operational powder mixer
- Factory-trained technician on-site
- Expert process guidance

"It proved so successful, we kept it. The chemist and I wouldn't let it leave. We were able to achieve results that we weren't able to achieve with the old system, and in only 30 minutes mixing time."

- E. Martinez, Coats Aloe International

Powder Mixer Options

The Fristam Powder Mixer is manufactured specifically for each order. Dimensions and configuration are fully customizable. However, industry specific option packages are offered.



BEVERAGE PACKAGE

- Double seals
- Drum unload port

DAIRY PACKAGE

- Rectangular funnel
- Funnel screen
- Funnel lid

PHARMA PACKAGE:

- Validation package
- Product testing & certifications
- Casing drains
- Diaphragm valves
- 15 Ra finish with electropolish on product contact areas

PERSONAL CARE PACKAGE:

- Variable frequency drive
- Funnel orifice

Powder Mixer Dimensional Drawing

There are six standard model sizes, depending on the powder being mixed and the flow rate.

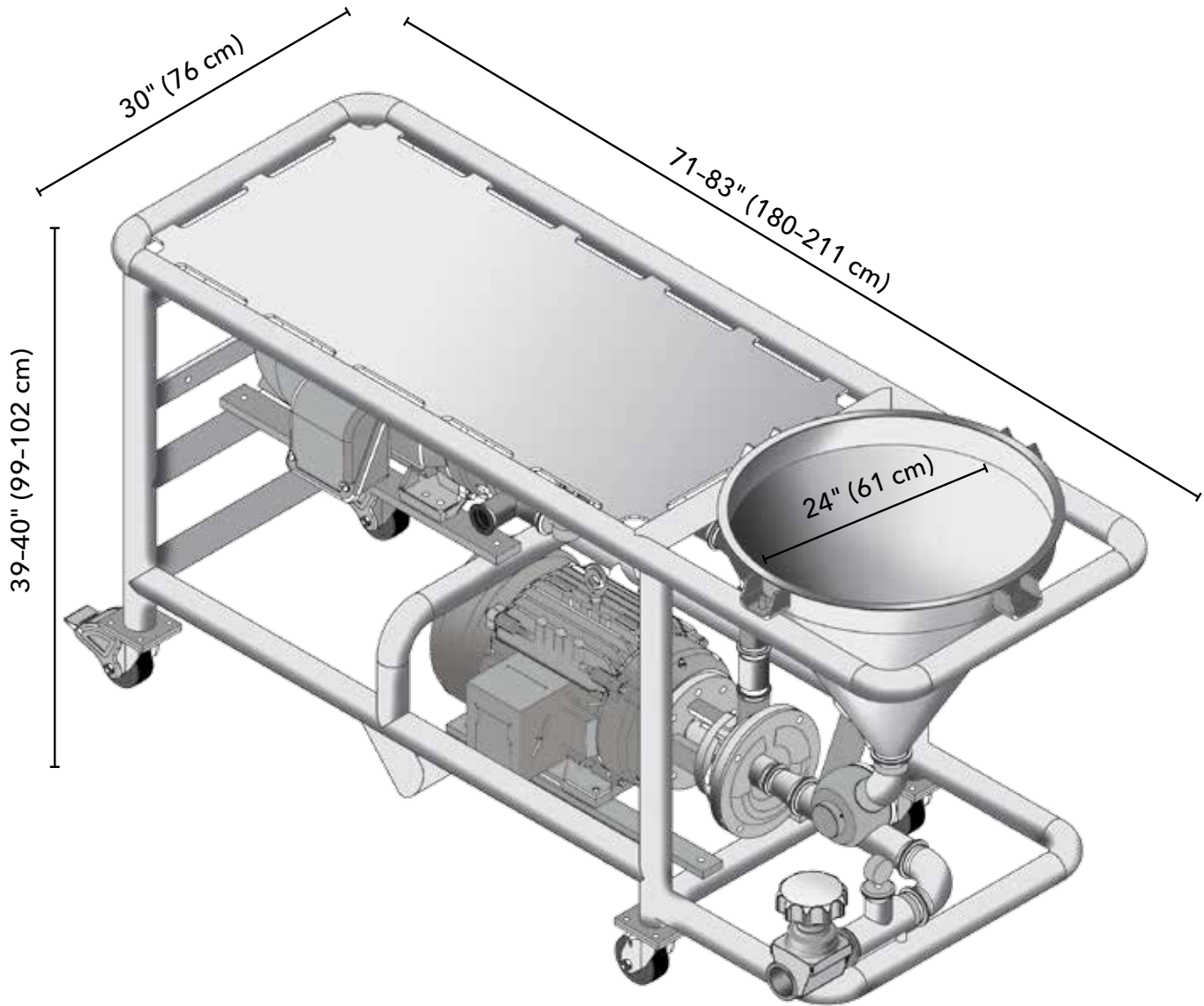

FSH	Induction Rate*	Liquid Flow	FSI Shear Blender	
Model	lbs/min	GPM	Model	HP
10-52	100	50	3522	15
15-53	175	90	3532	20
20-53	225	120	3532	25
25-54	350	180	3542	30
40-55	600	350	3552	75

* - Induction rate based on free flowing crystal sugar.

Composite Performance Curves



FRISTAM SHEAR PUMPS
FSI 1750 RPM

FSI 3500 RPM

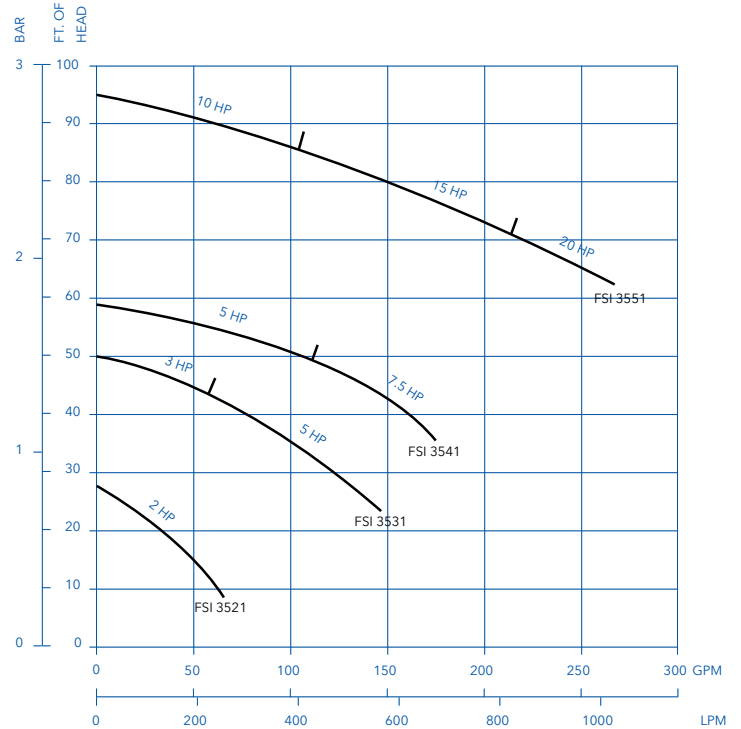
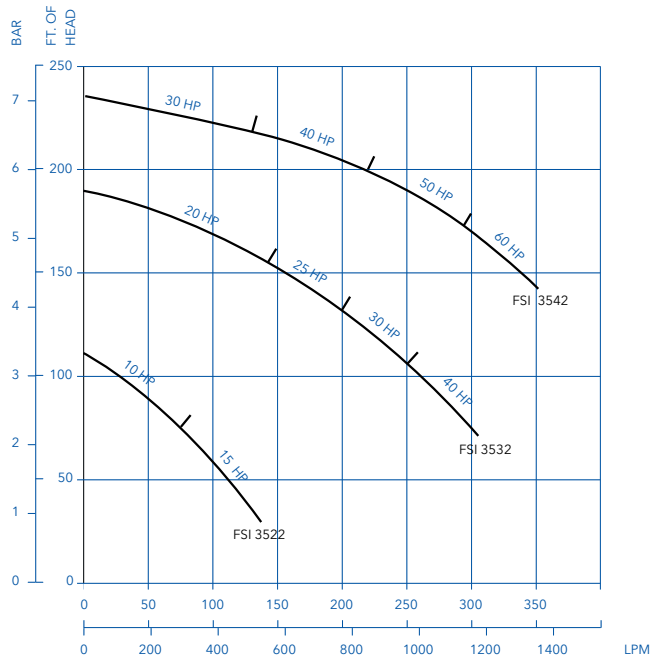

Архангельск (8182)63-90-72
Астана (7172)727-132
Астрахань (8512)99-46-04
Барнаул (3852)73-04-60
Белгород (4722)40-23-64
Брянск (4832)59-03-52
Владивосток (423)249-28-31
Волгоград (844)278-03-48
Вологда (8172)26-41-59
Воронеж (473)204-51-73
Екатеринбург (343)384-55-89
Иваново (4932)77-34-06

Ижевск (3412)26-03-58
Иркутск (395)279-98-46
Казань (843)206-01-48
Калининград (4012)72-03-81
Калуга (4842)92-23-67
Кемерово (3842)65-04-62
Киров (8332)68-02-04
Краснодар (861)203-40-90
Красноярск (391)204-63-61
Курск (4712)77-13-04
Липецк (4742)52-20-81
Киргизия (996)312-96-26-47

Магнитогорск (3519)55-03-13
Москва (495)268-04-70
Мурманск (8152)59-64-93
Набережные Челны (8552)20-53-41
Нижний Новгород (831)429-08-12
Новокузнецк (3843)20-46-81
Новосибирск (383)227-86-73
Омск (3812)21-46-40
Орел (4862)44-53-42
Оренбург (3532)37-68-04
Пенза (8412)22-31-16
Казахстан (772)734-952-31

Пермь (342)205-81-47
Ростов-на-Дону (863)308-18-15
Рязань (4912)46-61-64
Самара (846)206-03-16
Санкт-Петербург (812)309-46-40
Саратов (845)249-38-78
Севастополь (8692)22-31-93
Симферополь (3652)67-13-56
Смоленск (4812)29-41-54
Сочи (862)225-72-31
Ставрополь (8652)20-65-13
Таджикистан (992)427-82-92-69

Сургут (3462)77-98-35
Тверь (4822)63-31-35
Томск (3822)98-41-53
Тула (4872)74-02-29
Тюмень (3452)66-21-18
Ульяновск (8422)24-23-59
Уфа (347)229-48-12
Хабаровск (4212)92-98-04
Челябинск (351)202-03-61
Череповец (8202)49-02-64
Ярославль (4852)69-52-93

<https://fristam.nt-rt.ru/> || fmg@nt-rt.ru