



*Engineered For Lasting Performance®*

## INSTRUCTION AND MAINTENANCE MANUAL:

### FZX 2000 SERIES PUMP

Архангельск (8182)63-90-72  
Астана (7172)727-132  
Астрахань (8512)99-46-04  
Барнаул (3852)73-04-60  
Белгород (4722)40-23-64  
Брянск (4832)59-03-52  
Владивосток (423)249-28-31  
Волгоград (844)278-03-48  
Вологда (8172)26-41-59  
Воронеж (473)204-51-73  
Екатеринбург (343)384-55-89  
Иваново (4932)77-34-06

Ижевск (3412)26-03-58  
Иркутск (395)279-98-46  
Казань (843)206-01-48  
Калининград (4012)72-03-81  
Калуга (4842)92-23-67  
Кемерово (3842)65-04-62  
Киров (8332)68-02-04  
Краснодар (861)203-40-90  
Красноярск (391)204-63-61  
Курск (4712)77-13-04  
Липецк (4742)52-20-81  
Киргизия (996)312-96-26-47

Магнитогорск (3519)55-03-13  
Москва (495)268-04-70  
Мурманск (8152)59-64-93  
Набережные Челны (8552)20-53-41  
Нижегород (831)429-08-12  
Новокузнецк (3843)20-46-81  
Новосибирск (383)227-86-73  
Омск (3812)21-46-40  
Орел (4862)44-53-42  
Оренбург (3532)37-68-04  
Пенза (8412)22-31-16  
Казахстан (772)734-952-31

Пермь (342)205-81-47  
Ростов-на-Дону (863)308-18-15  
Рязань (4912)46-61-64  
Самара (846)206-03-16  
Санкт-Петербург (812)309-46-40  
Саратов (845)249-38-78  
Севастополь (8692)22-31-93  
Симферополь (3652)67-13-56  
Смоленск (4812)29-41-54  
Сочи (862)225-72-31  
Ставрополь (8652)20-65-13  
Таджикистан (992)427-82-92-69

Сургут (3462)77-98-35  
Тверь (4822)63-31-35  
Томск (3822)98-41-53  
Тула (4872)74-02-29  
Тюмень (3452)66-21-18  
Ульяновск (8422)24-23-59  
Уфа (347)229-48-12  
Хабаровск (4212)92-98-04  
Челябинск (351)202-03-61  
Череповец (8202)49-02-64  
Ярославль (4852)69-52-93

<https://fristam.nt-rt.ru/> || [fmg@nt-rt.ru](mailto:fmg@nt-rt.ru)

## TABLE OF CONTENTS

TECHNICAL INFORMATION .....	4
RECOMMENDED PREVENTIVE MAINTENANCE .....	5-6
SEAL REPLACEMENT .....	6
PUMP HEAD DISASSEMBLY .....	6-7
PUMP HEAD ASSEMBLY .....	7-9
SINGLE SEAL ASSEMBLY DRAWING (FZX 2100 - 2250 MODELS) .....	10
SINGLE SEAL ASSEMBLY DRAWING (FZX 2400 MODEL) .....	11
DOUBLE SEAL ASSEMBLY DRAWING (FZX 2100 - 2250 MODELS) .....	12
DOUBLE SEAL ASSEMBLY DRAWING (FZX 2400 MODEL) .....	13
PUMP SHAFT AND/OR MOTOR REPLACEMENT .....	14
PUMP DISASSEMBLY .....	14
PUMP ASSEMBLY .....	14
SETTING THE IMPELLER GAP .....	15
FZX EXPLODED VIEW .....	16-17
FZX 2100 PARTS LIST .....	18
FZX 2150 PARTS LIST .....	18
FZX 2200 PARTS LIST .....	19
FZX 2250 PARTS LIST .....	19
FZX 2400 PARTD LIDT .....	20
INSTALLATION .....	21
PIPING GUIDELINES .....	21
ELECTRICAL INSTALLATION .....	22
INSTALLATION OF WATER FLUSH FOR DOUBLE MECHANICAL SEAL .....	22
START-UP INSTRUCTIONS .....	22
TROUBLESHOOTING .....	23-25
NOTICE OF TERMS, WARRANTY PROVISIONS INCLUDING DISCLAIMERS, CLAIMS AND LIMITATION OF LIABILITY .....	27

## TECHNICAL INFORMATION

### SPECIFICATIONS

---

Maximum Inlet Pressure..... 150 PSI  
 Temperature Range ..... 13°F - 250°F  
 Noise Level.....60 - 85 dB(A)

### MATERIALS OF CONSTRUCTION

---

Major Product Contact Components .....AISI 316L  
 Cover Gasket.....BUNA (standard)  
     Also available in ..... Viton, EPDM, Silicone, Chemraz, Kalrez  
 Surface Finish for Product Contact Surfaces ..... 32 Ra (standard)  
     Also available in ..... 25 Ra, 20 Ra, electropolish

### SHAFT SEALS

---

Mechanical Seal Types..... Single or Double  
 Maximum Seal Water Pressure (double seal) ..... 5 PSI of water  
 Seal Water Consumption (double seal).....1-2 gph  
 Inner Stationary Seal Ring Material ..... Carbon (standard)  
     Also available in ..... Silicon Carbide  
 Outer Stationary Seal Ring Material..... Carbon  
 Rotating Seal Ring Material .....Chrome Oxide (standard)  
     Also available in ..... Silicon Carbide  
 Product O-ring Material ..... Viton (standard)  
     Also available in ..... others available upon request  
 Non-Product O-ring Material..... Viton (standard)

### IMPELLER GAP

---

FZX 2100, 2150, 2200, 2250 ..... 0.2 mm (0.008")  
 FZX 2400..... 0.5 mm (0.020")

### RECOMMENDED TORQUE VALUES:

---

Impeller nut		40 ft.-lb. (54 Nm)
Impeller bolt (FZX 2400 model only)		20 ft.-lb. (27 Nm)
Housing bolts		50 ft.-lb. (68 Nm)
Motor bolts (NEMA 180TC-250TC, IEC 100-132)		50 ft.-lb. (68 Nm)
Shaft clamping bolt		
NEMA 140TC-180TC	12 ft.-lbs	IEC 90-112    15 Nm
NEMA 210TC-250TC	24 ft.-lbs	IEC 132-180   40 Nm
NEMA 280TC-360TC	43 ft.-lbs	IEC 200-225   76 Nm

### MOTOR INFORMATION

Uses standard NEMA TEFC C-face motors. Options include washdown, high efficiency, explosion proof, chemical duty and IEC. *Motors may be modified with Belleville washers to limit motor shaft end play.* The TIR of the motor shaft should be 0.002" or less.

#### *Voltage and Frequency*

3 phase, 60 Hz, 208-230/460 VAC ..... 1750 RPM  
 3 phase, 60 Hz, 575 VAC..... 1750 RPM  
 3 phase, 50 Hz, 208-220/330-415 VAC ..... 1450 RPM

## RECOMMENDED PREVENTIVE MAINTENANCE

### RECOMMENDED SEAL MAINTENANCE:

---

Visually inspect mechanical seal daily for leakage.  
 Replace mechanical seal annually under normal duty.  
 Replace mechanical seal as often as required under heavy duty.  
 We recommend having a spare seal kit and cover gasket on hand.

### ELASTOMER INSPECTION

---

Inspect all elastomers when performing pump maintenance. We recommend replacing elastomers (o-rings and gaskets) during seal, pump shaft and/or motor replacements.

### PUMP SHAFT INSPECTION

---

Inspect annually for wear.

### FZX 2400 IMPELLER BOLT CLEANING

---

If the impeller bolt o-ring, impeller washer o-ring, or impeller o-ring fails, the threaded hole on the end of the shaft will need to be cleaned. We recommend removing the impeller and impeller bolt/washer while the pump is being CIP'd. This will ensure that the internal threads are cleaned before production resumes.

### LUBRICATION RECOMMENDATIONS:

---

Use a food grade lubricant on o-rings and gaskets unless otherwise specified. If using EPDM o-rings or gaskets, an oil-based lubricant can't be used.

### MOTOR LUBRICATION RECOMMENDATIONS:

---

Use a high grade ball and roller bearing grease. Recommendations for standard service conditions include *Shell Dolium R* or *Chevron SRI*.

### MOTOR LUBRICATION INTERVALS FOR STANDARD SERVICE CONDITIONS:

---

<i>FRAME SIZE</i>	<i>MOTOR SPEED</i>
<i>NEMA/(IEC)</i>	<i>1800 RPM</i>
Up to 210 (132) inclusive	12,000 hours
Over 210 to 280 (132 to 180) inclusive	9,500 hours
Over 280 to 360 (225) inclusive	7,400 hours

For severe service conditions, multiply interval hours by .5. For extreme service conditions, multiply interval hours by .1

### SERVICE CONDITION DEFINITIONS:

---

<i>SERVICE CONDITION</i>	<i>MAXIMUM AMBIENT TEMPERATURE</i>	<i>ATMOSPHERIC CONTAMINATION</i>
Standard	104°F (40°C)	Clean, little corrosion.
Severe	122°F (50°C)	Moderate dirt, corrosion.
Extreme	> 122°F (> 50°C)	Severe, dirt, abrasive dust, corrosion.

### VOLUME OF GREASE TO BE ADDED:

---

<i>Frame Size</i>	<i>Grease Volume</i>	
<i>NEMA/(IEC)</i>	<i>IN.<sup>3</sup></i>	<i>TSP</i>
Up to 210 (132) inclusive	0.6	2.0
Over 210 to 280 (132 to 180) inclusive	1.2	3.9
Over 280 to 360 (225) inclusive	4.1	13.4

## SEAL REPLACEMENT



Begin all pump maintenance by disconnecting the energy source to the pump. Observe all lock out/tag out procedures as outlined by ANSI Z244.1-1982 and OSHA 1910.147 to prevent accidental start-up and injury.

### TOOLS REQUIRED FOR SEAL REPLACEMENT:

---

Soft-faced hammer (5 lb. dead blow)  
 15/16" socket wrench  
 3/4" wrench  
 Small flat screw driver  
 3/8" diameter rod  
 One pair tack pullers (impeller pullers)  
 Torque wrench

### PUMP HEAD DISASSEMBLY

---

*Note:* the reference numbers listed in the text (#) refer to the assembly drawing on pages 16 & 17.

Disconnect the suction and discharge piping.

- a) Loosen the cover nuts (1) with the soft-faced hammer and remove. Note: fluid in pump will drain out.
- b) Remove the pump cover (2) and cover gasket (4).
- c) Remove the flange guard (31).
- d) Place the 3/8" diameter rod in the hole on the shaft. Allow the rod to rest against the pump flange support (23) to keep the shaft from rotating while loosening the impeller nut (3) with the 15/16" socket wrench (loosen the impeller bolt with 3/4" wrench on the 2400 model only) (*Figure 4*).
- e) Remove the impeller nut and impeller nut gasket (5). Discard the impeller nut gasket.
- f) Remove the impeller (6) by pulling the impeller toward you. Remove and discard the impeller o-ring (7). (If the impeller is difficult to pull off the shaft, wedge the tack pullers between the pump housing (9) and the impeller and pry the impeller off the shaft.)
- g) Remove the impeller key (20).
- h) Remove the three housing bolts (25) and washers (24) which attach the pump housing to the flange support (23) using the 3/4" wrench.
- i) Slide the pump housing off the end of the pump shaft (21).

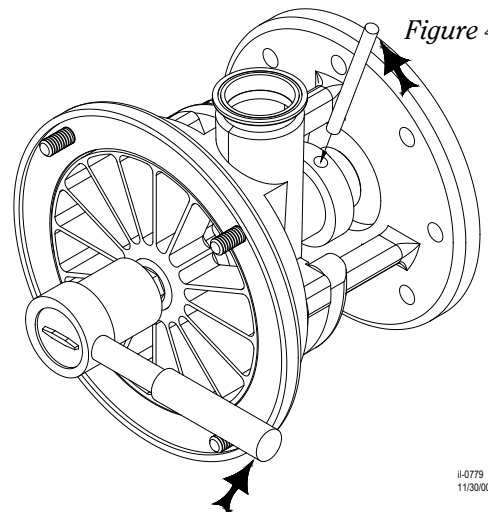

j) Place the pump housing (9) face down on the housing studs (8) (*Figure 5*).

k) Remove the stationary seal (16) by placing two fingers in the center of the seal and pulling up. Discard after removal.

*For Double Mechanical Seal* - remove both the inner and outer stationary seals (16 & 17) by placing your fingers in the center of the seals and pulling up. The seals should come out of the seal cavity as one unit (*Figure 5*). Discard after removal.

l) Remove and discard the wave spring (14).

*For Double Mechanical Seal* - remove and discard both the inner and outer wave springs (13 & 14).

m) Remove the inner stationary seal o-ring (11) with a small flat screwdriver. Discard after removal.

*For Double Mechanical Seal* - remove and discard both the inner and outer stationary seal o-rings (11 & 15) with a small flat screwdriver.

n) Pull the rotating seal (18) off the shaft and discard. Also remove and discard the rotating seal o-ring (19).

**PUMP HEAD ASSEMBLY (SEE SEAL ASSEMBLY DRAWINGS FIGURE 8, 8A, 9 & 9A, PAGES 11-14.)**

Note: when installing the new seal components make sure that you use all the components supplied with the replacement seal kit. Using some of the old components may reduce seal life.

You are now ready to install the new mechanical seal into the pump.

a) Start by lubricating the new rotating seal o-ring (19) with a food grade lubricant (unless the o-ring is EPDM) and placing it into the rotating seal (18).

b) Snap the new rotating seal into place on the shaft. (The rotating seal will fit into the grooves on the shaft and interlock with the shaft. If you can rotate the seal ring on the shaft, it is not properly seated.)

c) Lubricate the new inner stationary seal o-ring (11) with a food grade lubricant and place into seal cavity.

*For Double Mechanical Seal* - lubricate both the new inner and outer stationary seal o-rings (11 & 15) and place into the seal cavity.

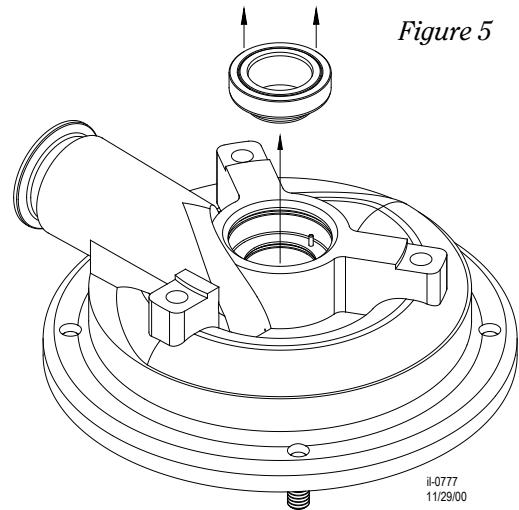

d) Place the inner wave spring (14) into the seal cavity. Align the notches in the wave spring with the pins in the seal cavity. Place the wave spring with the waves in a downward position around the pins (*Figure 6*).

For *Double Mechanical Seal* - place both the inner and outer wave springs (14 & 13) into the seal cavity. Align the notches in the inner wave spring with the pins in the seal cavity and place on the inside of the pins. Align the notches in the outer wave spring with the pins in the seal cavity and place on the outside of the pins. Again, it fits best if the waves around the pins are in a downward position (*Figure 6*).

e) Insert the new inner stationary seal (16) aligning the notches with the pins in the seal cavity. (If you touch the face of the seal, clean with isopropyl alcohol.)

For *Double Mechanical Seal* - after the new inner stationary seal (16) is in place, the new outer stationary seal (17) will need to be installed. Align the notches in the outer stationary seal with the pins in the seal cavity. The outer stationary seal will fit around the inner stationary seal that is already in place.

f) Carefully slide the pump housing (9) on the pump shaft, ensuring that the stationary seal (which is mounted inside the pump housing) does not contact the pump shaft. The stationary seal may be damaged if it makes hard contact with the pump shaft.) Make sure the discharge fitting is in the correct position.

g) Install and tighten the three housing bolts (25) with the 3/4" wrench to the correct torque (see page 4).

h) Place the impeller key (20) into the keyway on the shaft (21).

i) Lubricate the new impeller o-ring (7) and place in the groove on back of the impeller (6).

j) Slide the impeller onto the pump shaft.

k) Lubricate the new impeller nut gasket (5) and place on the impeller nut (3).

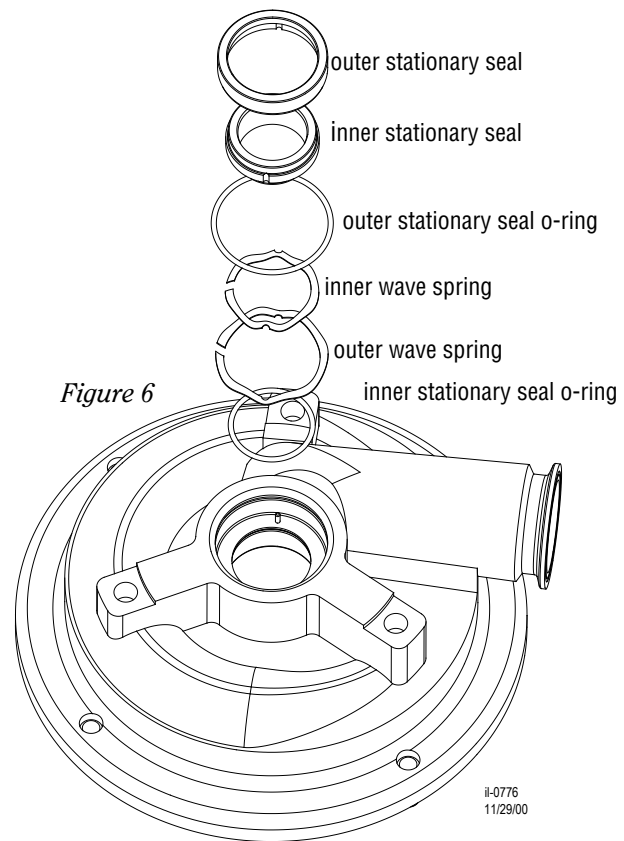

*Figure 6*

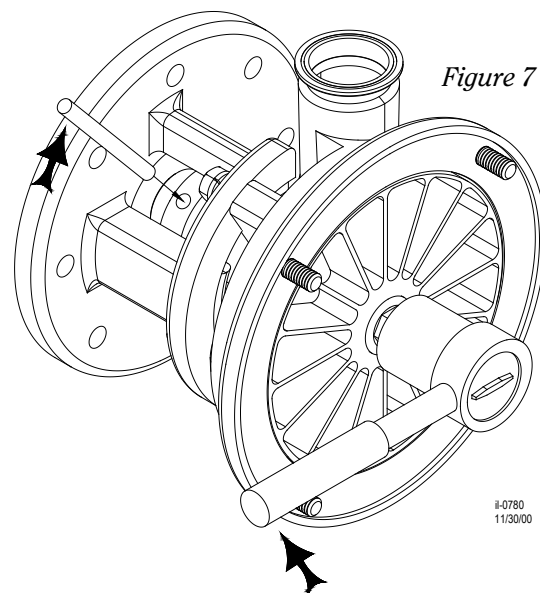

*Figure 7*

- l) Place the 3/8" diameter rod in the shaft. Allow the rod to rest against the pump flange support (23) to keep the shaft from rotating while tightening the impeller nut (3) with the 15/16" socket wrench (tighten the impeller bolt with a 3/4" socket on the FZX 2400 model only) to the appropriate torque (see page 5).
- m) Place the cover gasket (4) in the groove on the pump cover (2). *Note:* when installing the cover gasket, gently stretch the gasket to aid in assembly. Do not roll the gasket into position. Next install the pump cover onto the front of the pump and thread the cover nuts (1) onto the housing studs (8). *Note:* the pump cover only fits onto the housing one way. The pump serial number is embossed into the 'top' of the pump cover.
- n) Tighten the cover nuts with the soft-faced hammer.

Now rotate the pump shaft (21) to make sure that the impeller (6) moves freely. If it does not, recheck your assembly to make sure that gaskets are not pinched and everything is seated properly. Listen to the pump as you turn the shaft. A small amount of noise from the seals is normal, but if there is metal-to-metal contact, the sound will be noticeable. If there is metal-to-metal contact, check the impeller gap (see page 16) and total indicated run-out of the pump shaft (see page 17). Regap the impeller or align the shaft if necessary.

Replace the flange guard (31) using the guard screws (22).

Reconnect the suction and discharge piping.



Figure 8: Single Seal Assembly for FZX 2100 - 2250 models

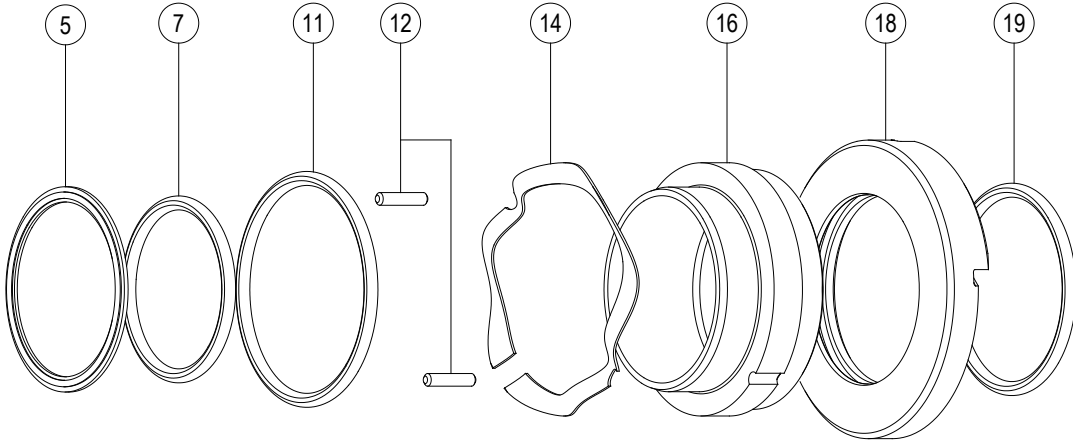

- |                                |                         |
|--------------------------------|-------------------------|
| ⑤ IMPELLER NUT GASKET          | ⑬ INNER STATIONARY SEAL |
| ⑦ IMPELLER O-RING              | ⑭ ROTATING SEAL         |
| ⑪ INNER STATIONARY SEAL O-RING | ⑮ ROTATING SEAL O-RING  |
| ⑫ PIN                          |                         |
| ⑭ INNER STATIONARY SEAL SPRING |                         |

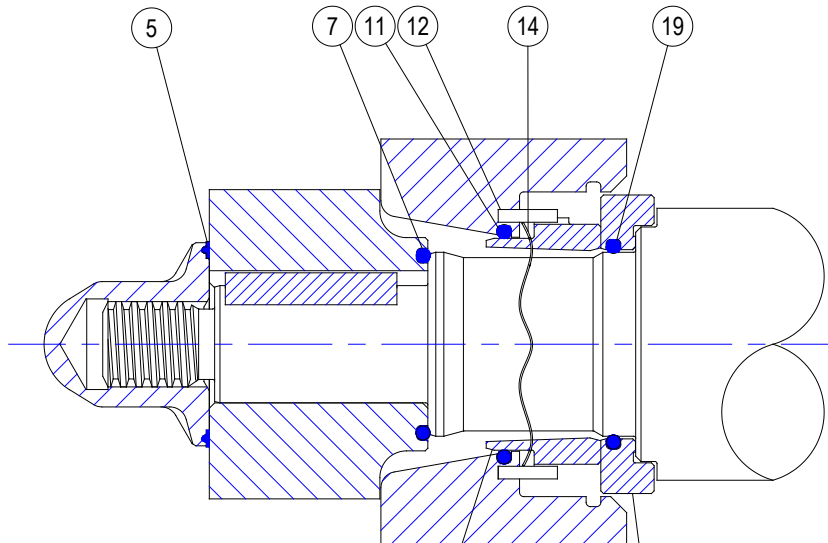
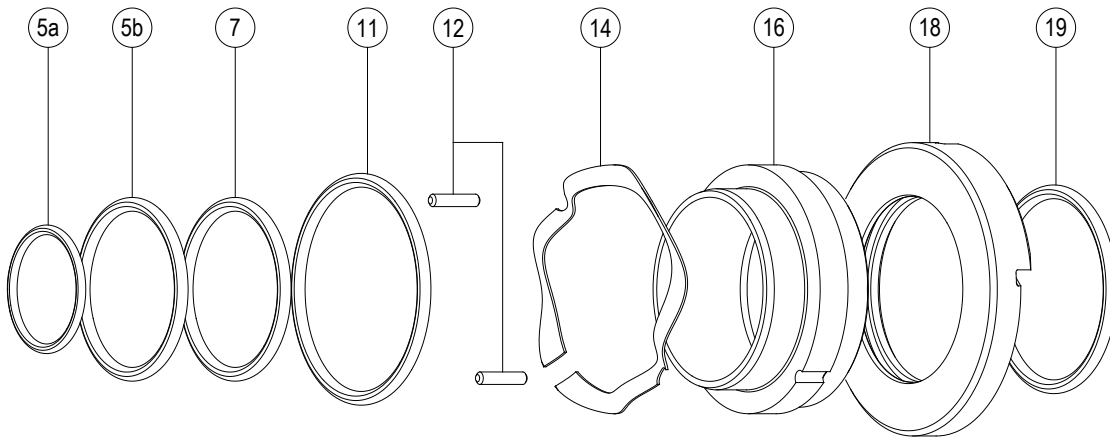

Figure 8a: Single Seal Assembly for FZX 2400 model



- |    |                              |    |                       |
|----|------------------------------|----|-----------------------|
| 5a | IMPELLER BOLT O-RING         | 16 | INNER STATIONARY SEAL |
| 5b | IMPELLER WASHER O-RING       | 18 | ROTATING SEAL         |
| 7  | IMPELLER O-RING              | 19 | ROTATING SEAL O-RING  |
| 11 | INNER STATIONARY SEAL O-RING |    |                       |
| 12 | PIN                          |    |                       |
| 14 | INNER STATIONARY SEAL SPRING |    |                       |

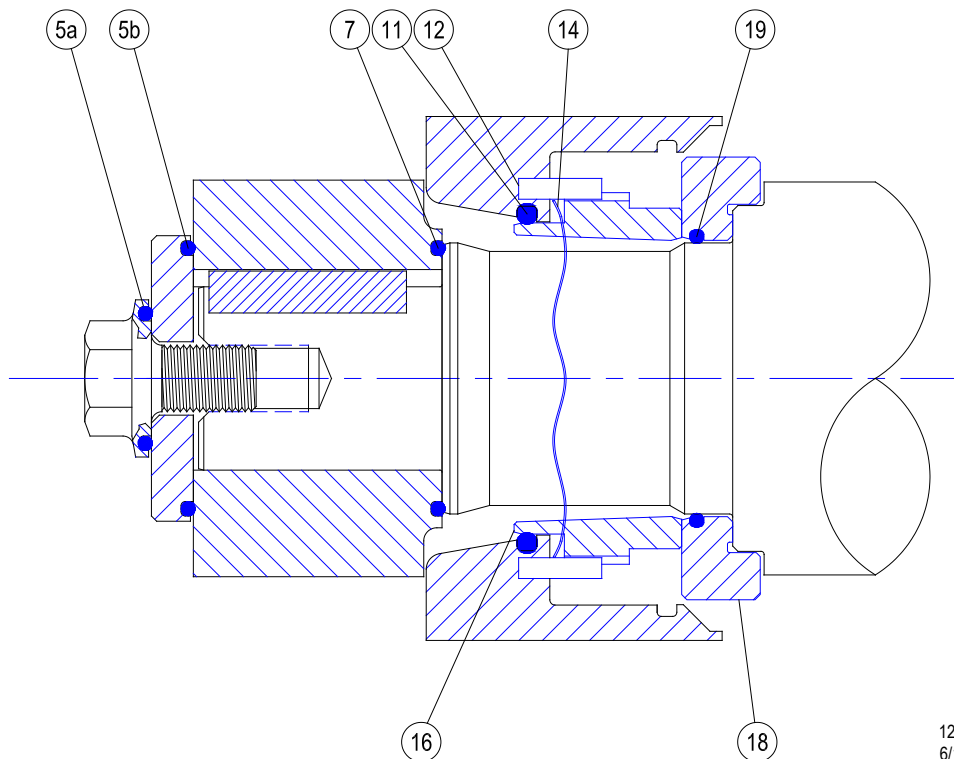
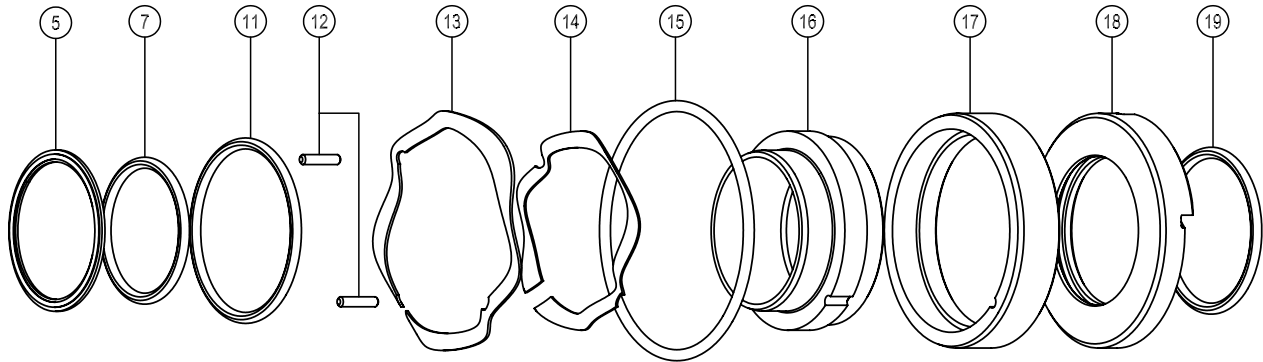
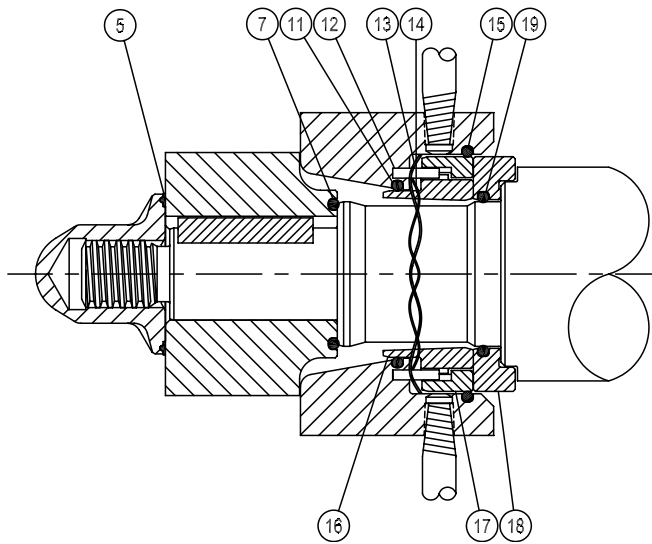

Figure 9: Double Seal Assembly for the FZX 2100 - 2250 models



- |                                |                                |
|--------------------------------|--------------------------------|
| ⑤ IMPELLER NUT GASKET          | ⑮ OUTER STATIONARY SEAL O-RING |
| ⑦ IMPELLER O-RING              | ⑯ INNER STATIONARY SEAL        |
| ⑪ INNER STATIONARY SEAL O-RING | ⑰ OUTER STATIONARY SEAL        |
| ⑫ PIN                          | ⑱ ROTATING SEAL                |
| ⑬ OUTER STATIONARY SEAL SPRING | ⑲ ROTATING SEAL O-RING         |
| ⑭ INNER STATIONARY SEAL SPRING |                                |



1265000043  
6/19/02

Figure 9a: Double Seal Assembly for the FZX 2400 model

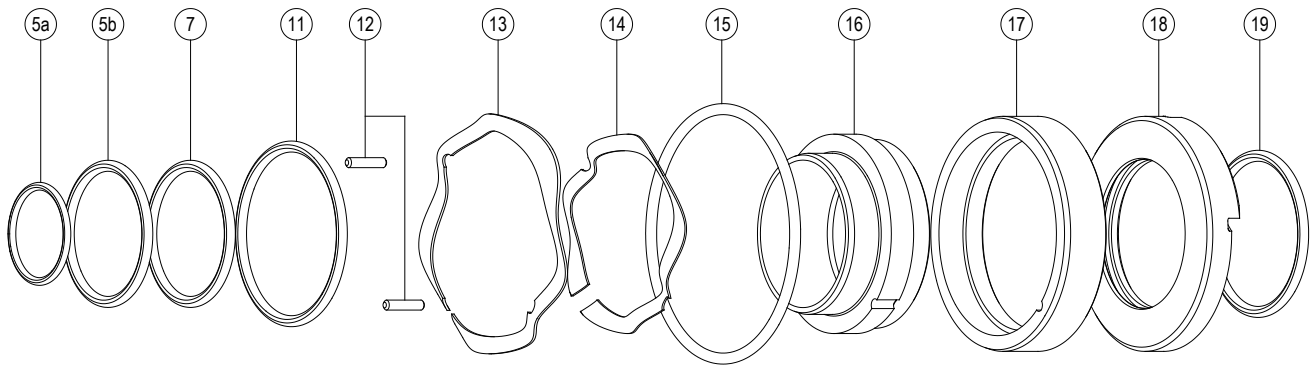

- |    |                              |   |                              |
|----|------------------------------|---|------------------------------|
| ⑤a | IMPELLER BOLT O-RING         | ⑮ | OUTER STATIONARY SEAL O-RING |
| ⑤b | IMPELLER WASHER O-RING       | ⑯ | INNER STATIONARY SEAL        |
| ⑦  | IMPELLER O-RING              | ⑰ | OUTER STATIONARY SEAL        |
| ⑪  | INNER STATIONARY SEAL O-RING | ⑱ | ROTATING SEAL                |
| ⑫  | PIN                          | ⑲ | ROTATING SEAL O-RING         |
| ⑬  | OUTER STATIONARY SEAL SPRING |   |                              |
| ⑭  | INNER STATIONARY SEAL SPRING |   |                              |

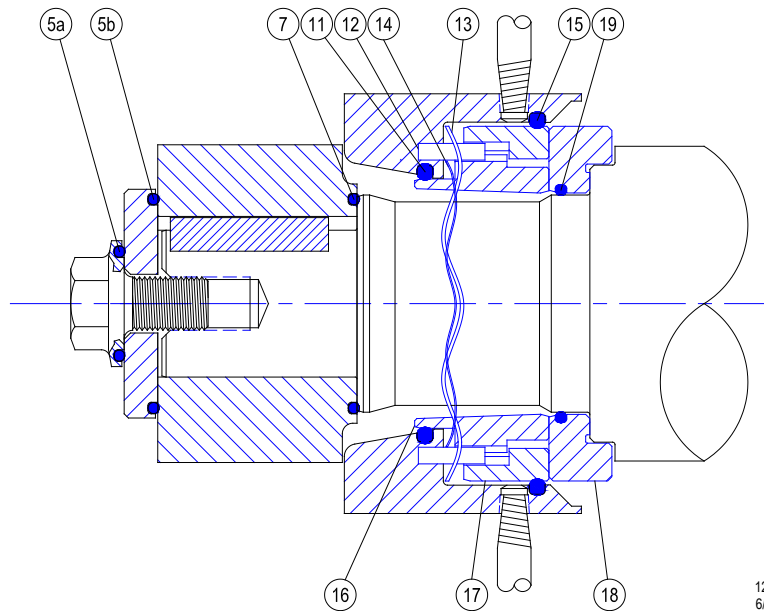

126500044  
6/19/02

## PUMP SHAFT AND/OR MOTOR REPLACEMENT



Begin all pump maintenance by disconnecting the energy source connected to the pump. Observe all lock out/tag out procedures as outlined by ANSI Z244.1-1982 and OSHA 1910.147 to prevent accidental start-up and injury.

### **TOOLS REQUIRED FOR PUMP SHAFT AND/OR MOTOR REPLACEMENT:**

---

- 3/4" wrench
- 3/4" socket
- 1/4" Allen wrench
- Plastic gapping spacer (supplied by Fristam)
- 3/8" diameter rod
- 15/16" socket wrench
- Soft-face hammer

### **PUMP DISASSEMBLY**

---

Disassemble the pump head as described on pages 6-7.

a) Loosen the shaft clamping bolt (26) (or shaft clamping bolts for the FZX 2400 model) with the 1/4" Allen wrench.

b) Pull the pump shaft (21) off the motor shaft.

If you are replacing the motor (27), the flange support (23) must be removed.

a) Loosen and remove the four motor bolts (33) with the 3/4" wrench. Also remove the washers (32).

b) Remove the flange support from the motor.

c) Clean off the motor face of the flange support and lubricate liberally with a food grade grease such as NEVER-SEEZ.

### **PUMP ASSEMBLY**

---

If replacing the motor check to make sure Belleville washers are installed to reduce motor shaft end play. It is recommended to check the TIR (total indicated run-out) of the motor shaft before using the new motor. If the TIR is not within .002" call your motor supplier.

Replacing the motor - Place the flange support (23) on the new motor (27), replace the motor bolts (33) and washers (32) and tighten to the appropriate torque (see page 5).

To replace the pump shaft:

a) Lubricate the inside of the pump shaft (21) liberally with NEVER-SEEZ.

b) Slide the pump shaft onto the motor shaft. Note: the pump shaft should slide freely on motor shaft.

### **SETTING THE IMPELLER GAP**

---

The next step is to gap the pump shaft.

- a) Place the pump housing (9) onto the flange support (23). *Note:* it is recommended not to have the mechanical seals in place for gapping the pump.
- b) Install the housing bolts (8) and tighten with a 3/4" wrench.
- c) Install the pump shaft key (20).
- d) Place the correct plastic gapping shim (page 4) over the pump shaft and slide it against the pump housing. Slide the impeller onto the pump shaft. (The gapping shim is supplied with the pump. Additional shims may be ordered from Fristam Pumps, Inc.)
- e) Place the impeller nut (or impeller bolt) (3) onto the pump shaft (21).
- f) Place the 3/8" diameter rod in the hole on the shaft. Allow the rod to rest against the flange support (23) to keep the shaft from rotating while tightening the impeller nut with the 15/16" socket wrench (tighten the impeller bolt with the 3/4" socket wrench for the FZX 2400 model). Tighten to the correct torque (see page 5).
- g) Push on the impeller nut (3) until the shim is tight between the impeller (6) and housing (9). See *Figure 10*.
- h) *Align the slot of the clamping ring (26) directly over one of the slots on the shaft (Figure 11).*
- g) Secure the shaft clamping bolt with the 1/4" Allen wrench (*Figure 10*) to the specified torque (see page 5).
- i) Now remove the impeller nut (3) (or impeller bolt for the FZX 2400 model), impeller (6), impeller key (20), shim and pump housing (9).

Assemble the pump head as described on pages 7-9.

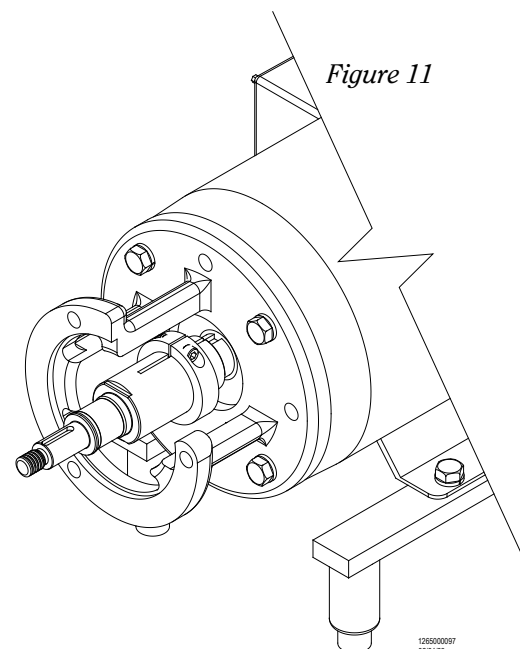
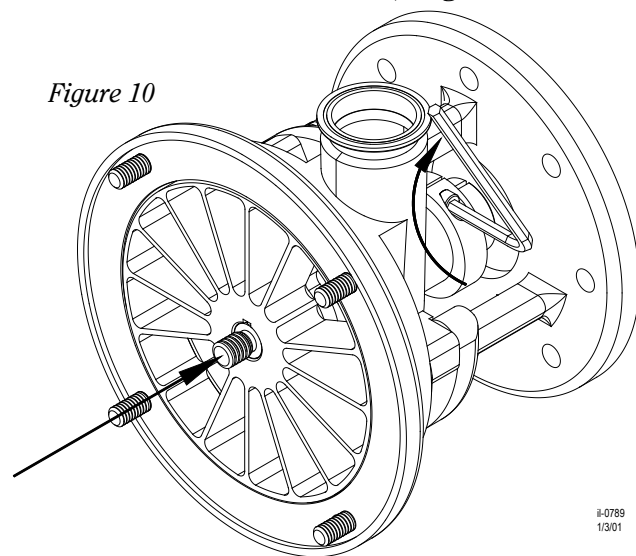

# FIGURE 14: EXPLODED VIEW OF FZX

- 1. Cover Nut
- 2. Pump Cover
- 3. Impeller Nut
- 3a. Impeller Bolt\*
- 3b. Impeller Bolt Washer \*
- 4. Cover Gasket
- 5. Impeller Nut Gasket
- 5a. Impeller Bolt O-ring\*
- 5b. Impeller Washer O-ring\*
- 6. Impeller
- 7. Impeller O-ring
- 8. Housing Studs
- 9. Pump Housing
- 10. Water Pipes

## DOUBLE EXTERNAL SEAL

- 11. Inner Stationary Seal O-ring
- 12. Pin
- 13. Outer Stationary Seal Spring
- 14. Inner Stationary Seal Spring
- 15. Outer Stationary Seal O-ring
- 16. Inner Stationary Seal
- 17. Outer Stationary Seal
- 18. Rotating Seal
- 19. Rotating Seal O-ring

- 20. Impeller Key
  - 21. Pump shaft
  - 22. Guard Screws
  - 23. Flange Support
  - 24. Housing Bolt Washer
  - 25. Housing Bolt
  - 26. Shaft Clamping Ring
  - 26a. Shaft Clamping Ring\*
  - 27. Motor
  - 28. Leg Bolt
  - 29. Leg Bolt Washer
  - 30. Leg Strap
  - 31. Flange Guard
  - 32. Motor Bolt Washer
  - 33. Motor Bolt
- \*parts for the FZX 2400 model only

## SINGLE EXTERNAL SEAL

- 11. Inner Stationary Seal O-ring
- 12. Pin
- 14. Inner Seal Spring
- 16. Inner Stationary Seal
- 18. Rotating Seal
- 19. Rotating Seal O-ring

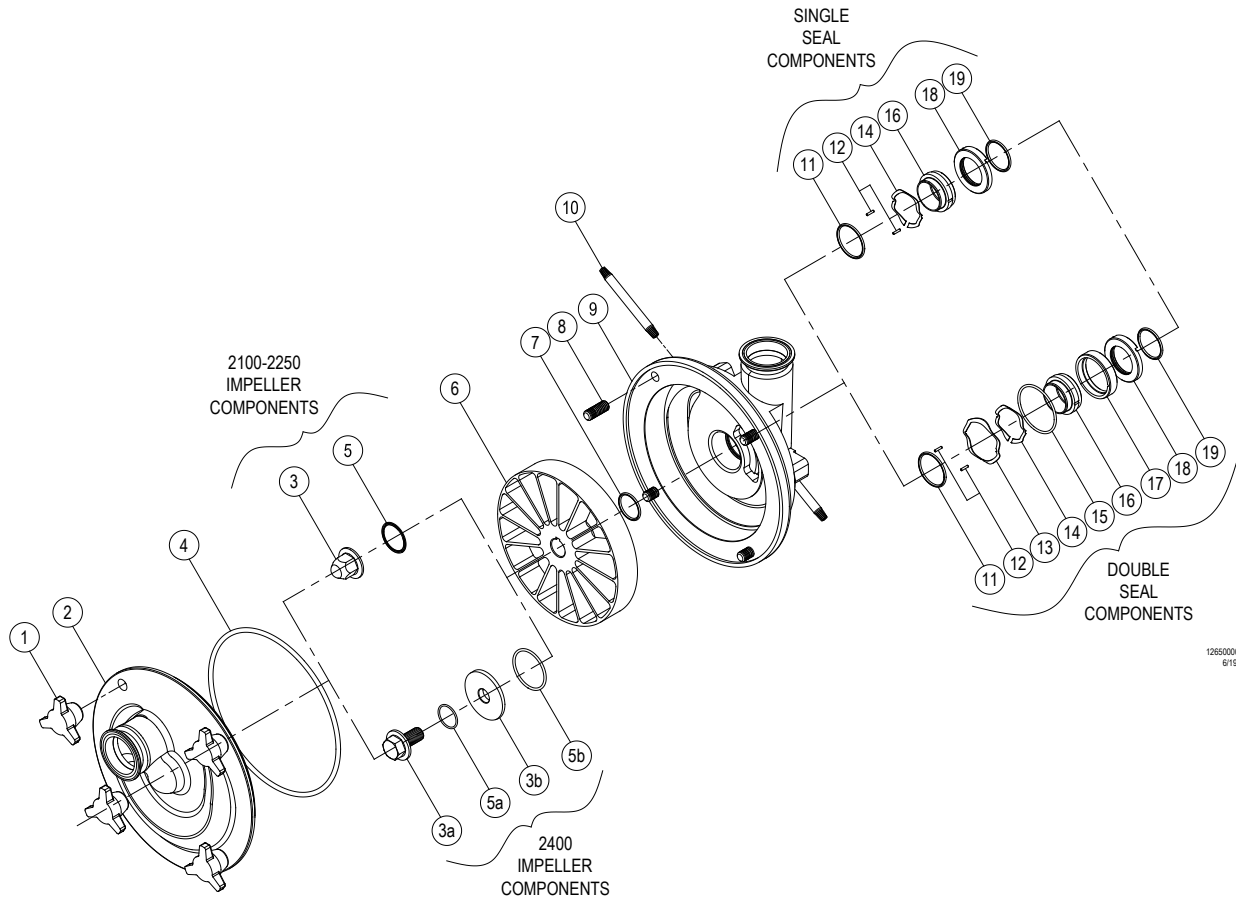

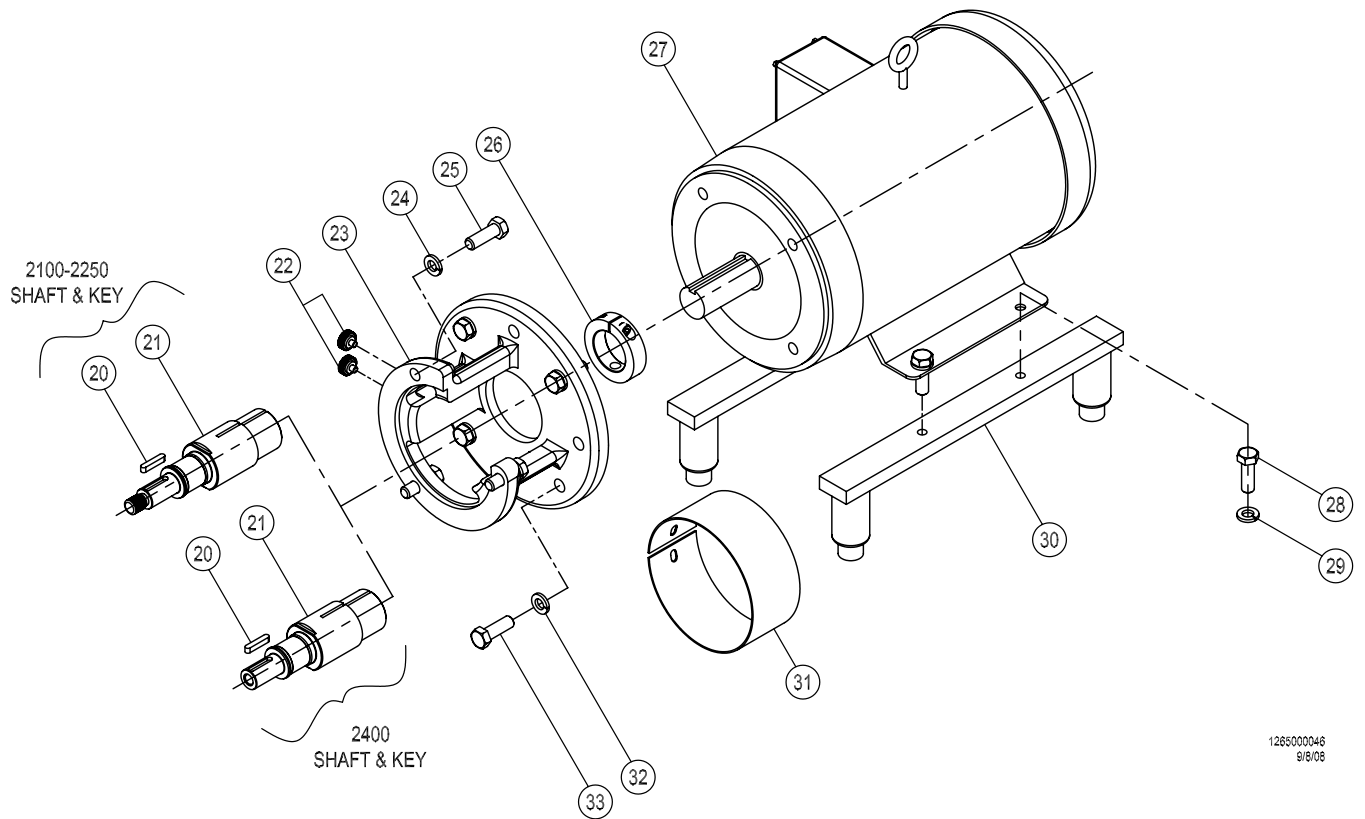



## FZX 2100 PARTS LIST

## FZX 2150 PARTS LIST

Item No.	Description	Part Number	Previous Part No.	Qty.	Item No.	Description	Part Number	Previous Part No.	Qty.
1	Cover nut	1103000028	58504738	3	1	Cover nut	1103000028	58504738	4
2	Pump cover	1508620000	59507185	1	2	Pump cover	1508620001	59507186	1
3	Impeller nut	1954000007	53501835	1	3	Impeller nut	1954000007	53501835	1
4	Cover gasket (buna)	1180000334	65500048	1	4	Cover gasket (buna)	1180000334	65500048	1
5	Impeller nut gasket	1181000083	65501825	1	5	Impeller nut gasket	1181000083	65501825	1
6	Impeller	1508630000	55507185	1	6	Impeller	1508630000	55507185	1
7	Impeller o-ring	1180000095	65503353	1	7	Impeller o-ring	1180000095	65503353	1
8	Housing studs (M12 x 33SS)	1103000001	58500317	3	8	Housing studs (M12 x 33SS)	1103000001	58500317	3
9	Pump housing - ss	1508610000	57507142	1	9	Pump housing - ss	1508610000	57507142	1
	Pump housing - ds	1508610001	57508126	1		Pump housing - ds	1508610001	57508126	1
10	Water pipes	1910000007	58500714	2	10	Water pipes	1910000007	58500714	2
11	Inner stationary seal o-ring (viton)	1180000398	65507191	1	11	Inner stationary seal o-ring (viton)	1180000398	65507191	1
12	Pin	1891000012	66507139	2	12	pin	1891000012	66507139	2
13	Outer stationary seal spring	1820000042	66507195	1	13	Outer stationary seal spring	1820000042	66507195	1
14	Inner seal spring	1820000041	66507194	1	14	Inner seal spring	1820000041	66507194	1
15	Outer stationary seal o-ring (viton)	1180000115	65503717	1	15	Outer stationary seal o-ring (viton)	1180000115	65503717	1
16	Inner stationary seal (carbon)	1815600063	66507151	1	16	Inner stationary seal (carbon)	1815600063	66507151	1
17	Outer stationary seal (carbon)	1815600042	66507152	1	17	Outer stationary seal (carbon)	1815600042	66507152	1
18	Rotating seal (chrome oxide coated)	1810600051	66507150	1	18	Rotating seal (chrome oxide coated)	1810600051	66507150	1
19	Rotating seal o-ring (viton)	1180000086	65503080	1	19	Rotating seal o-ring (viton)	1180000086	65503080	1
20	Impeller key	1315000018	53500310	1	20	Impeller key	1315000018	53500310	1
21	Impeller shaft (180 frame)	1302000005	52507179	1	21	Impeller shaft (210 frame)	1302000015	52507180	1
	Impeller shaft (210 frame)	1302000015	52507180	1		Impeller shaft (100/112 IEC frame)	1302000016	52507181	1
	Impeller shaft (100/112 IEC frame)	1302000016	52507181	1		Guard screws	1102000000	63501412	2
22	Guard screws	1102000000	63501412	2	22	Guard screws	1102000000	63501412	2
23	Flange support	1310600036	62507139	1	23	Flange support	1310600036	62507139	1
	Flange support (110/112 IEC frame)	1310600058	62507190	1		Flange support (110/112 IEC frame)	1310600058	62507190	1
24	Housing bolt washer	1104000006	13506364	4	24	Housing bolt washer	1104000006	13506364	4
25	Housing bolt	1101000037	13505799	4	25	Housing bolt	1101000037	13505799	4
26	Shaft clamping ring (180 frame)	1318000014	53504917	1	26	Shaft clamping ring (210 frame)	1318000015	53504918	1
	Shaft clamping ring (210 frame)	1318000015	53504918	1		Shaft clamping ring (100/112 IEC frame)	1318000018	53505769	1
	Shaft clamping ring (100/112 IEC frame)	1318000018	53505769	1	31	Flange guard	1936000043	63507189	1
31	Flange guard	1936000043	63507189	1	32	Motor bolt washer	1104000031	13500568	4
32	Motor bolt washer	1104000031	13500568	4	33	Motor bolt	1101000082	13500564	4
33	Motor bolt	1101000082	13500564	4					

## FZX 2200 PARTS LIST

## FZX 2250 PARTS LIST

Item No.	Description	Part Number	Previous Part No.	Qty.	Item No.	Description	Part Number	Previous Part No.	Qty.
1	Cover nut	1103000028	58504738	4	1	Cover nut	1103000028	58504738	5
2	Pump cover	1512620000	59506256	1	2	Pump cover (2.5" fitting)	1514620000	59507187	1
3	Impeller nut	1954000007	53501835	1	3	Impeller nut	1954000007	53501835	1
4	Cover gasket (buna)	1180000363	65504685	1	4	Cover gasket (buna)	1180000363	65504685	1
5	Impeller nut gasket	1181000083	65501825	1	5	Impeller nut gasket	1181000083	65501825	1
6	Impeller	1512630000	55506255	1	6	Impeller	1514630000	55507189	1
7	Impeller o-ring	1180000095	65503353	1	7	Impeller o-ring	1180000095	65503353	1
8	Housing studs (M12 x 33SS)	1103000001	58500317	4	8	Housing studs (M12 x 33SS)	1103000001	58500317	5
9	Pump housing - ss	1512610000	57507146	1	9	Pump housing - ss	1514610000	57507143	1
	Pump housing - ds	1512610001	57508127	1		Pump housing - ds	1514610001	57508128	1
10	Water pipes	1910000007	58500714	2	10	Water pipes	1910000007	58500714	2
11	Inner stationary seal o-ring (viton)	1180000398	65507191	1	11	Inner stationary seal o-ring (viton)	1180000398	65507191	1
12	pin	1891000012	66507139	2	12	pin	1891000012	66507139	2
13	Outer stationary seal spring	1820000042	66507195	1	13	Outer stationary seal spring	1820000042	66507195	1
14	Inner seal spring	1820000041	66507194	1	14	Inner seal spring	1820000041	66507194	1
15	Outer stationary seal o-ring (viton)	1180000115	65503717	1	15	Outer stationary seal o-ring (viton)	1180000115	65503717	1
16	Inner stationary seal (carbon)	1815600063	66507151	1	16	Inner stationary seal (carbon)	1815600063	66507151	1
17	Outer stationary seal (carbon)	1815600042	66507152	1	17	Outer stationary seal (carbon)	1815600042	66507152	1
18	Rotating seal (chrome oxide coated)	1810600051	66507150	1	18	Rotating seal (chrome oxide coated)	1810600051	66507150	1
19	Rotating seal o-ring (viton)	1180000086	65503080	1	19	Rotating seal o-ring (viton)	1180000086	65503080	1
20	Impeller key	1315000018	53500310	1	20	Impeller key	1315000018	53500310	1
21	Impeller shaft (180 frame)	1302000005	52507179	1	21	Impeller shaft (180 frame)	1302000005	52507179	1
	Impeller shaft (210 frame)	1302000015	52507180	1		Impeller shaft (210 frame)	1302000015	52507180	1
	Impeller shaft (250 frame)	1302000023	52507148	1		Impeller shaft (250 frame)	1302000023	52507148	1
	Impeller shaft (100/112 IEC frame)	1302000016	52507181	1		Impeller shaft (100/112 IEC frame)	1302000016	52507181	1
	Impeller shaft (132 IEC frame)	1302000017	52507182	1		Impeller shaft (132 IEC frame)	1302000017	52507182	1
22	Guard screws	1102000000	63501412	2	22	Guard screws	1102000000	63501412	2
23	Flange support (180-250 frame)	1310600036	62507139	1	23	Flange support (180-250 frame)	1310600036	62507139	1
	Flange support (110/112 IEC frame)	1310600058	62507190	1		Flange support (110/112 IEC frame)	1310600058	62507190	1
	Flange support (132 IEC frame)	1310600059	62507198	1		Flange support (132 IEC frame)	1310600059	62507198	1
24	Housing bolt washer	1104000006	13506364	4	24	Housing bolt washer	1104000006	13506364	4
25	Housing bolt	1101000037	13505799	4	25	Housing bolt	1101000037	13505799	4
26	Shaft clamping ring (180 frame)	1318000014	53504917	1	26	Shaft clamping ring (180 frame)	1318000014	53504917	1
	Shaft clamping ring (210 frame)	1318000015	53504918	1		Shaft clamping ring (210 frame)	1318000015	53504918	1
	Shaft clamping ring (250 frame)	1318000016	53504919	1		Shaft clamping ring (250 frame)	1318000016	53504919	1
	Shaft clamping ring (100/112 IEC frame)	1318000018	53505769	1		Shaft clamping ring (100/112 IEC frame)	1318000018	53505769	1
	Shaft clamping ring (132 IEC frame)	1318000019	53505065	1		Shaft clamping ring (132 IEC frame)	1318000019	53505065	1
31	Flange guard	1936000043	63507189	1	31	Flange guard	1936000043	63507189	1
32	Motor bolt washer	1104000031	13500568	4	32	Motor bolt washer	1104000031	13500568	4
33	Motor bolt	1101000082	13500564	4	33	Motor bolt	1101000082	13500564	4

## FZX 2400 PARTS LIST

Item No.	Description	Part Number	Qty.
1	Cover nut	1103000028	5
2	Pump cover (3" fitting)	1518620000	1
3a	Impeller bolt	1102000001	1
3b	Impeller bolt washer	1104000049	1
4	Cover gasket (buna)	1180000020	1
5a	Impeller bolt o-ring	1180000085	1
5b	Impeller washer oring	1180000474	1
6	Impeller	1518230000	1
7	Impeller o-ring	1180000474	1
8	Housing studs (M12 x 33SS)	1103000013	5
9	Pump housing - w/3" fitting	1518610000	1
10	Water pipes	1910000007	2
11	Inner stationary seal o-ring (viton)	1180000233	1
12	Seal pin (5/32" od by 5/8" long ss)	1891000033	2
13	Seal spring, double	1820000050	1
14	Seal spring, single	1820000048	1
15	Outer stationary seal o-ring (viton)	1180000234	1
16	Inner stationary seal (carbon)	1815600088	1
	Inner stationary seal (silicon carbide)	1815600089	
17	Outer stationary seal (carbon)	1815600090	1
18	Rotating seal (chrome oxide coated)	1810600095	1
	Rotating seal (silicon carbide)	1810600096	
19	Rotating seal o-ring (viton)	1180000467	1
20	Impeller key	1315000033	1
21	Impeller shaft (324-326TC)	1302000092	
	Impeller shaft (364-365TC)	1302000093	
22	Guard screws	1102000000	2
23	Flange support (324-365TC)	1310600080	1
24	Housing bolt washer	1104000013	4
25	Flange bolt	1101000001	4
26	Shaft clamping ring (324-326TC)	1318000028	1
	Shaft clamping ring (364-365TC)	1318000029	1
27	Motor		1
28	Leg bolt		
29	Leg bolt washer		
30	Leg strap	1920000049	
31	Flange guard	1936000080	1
32	Lock washer	1104000037	4
33	Motor bolt	1101000110	4

# INSTALLATION

## UNPACKING EQUIPMENT

Check the contents and all wrapping when unpacking the pump. Inspect the pump carefully for any damage that may have occurred during shipping. Immediately report any damage to the carrier. Remove the shaft guard and rotate the pump shaft by hand to make sure the impeller rotates freely. Keep the protective caps over the pump inlet and outlet in place until you are ready to install the pump.

## PIPING AND INSTALLATION GUIDELINES

- Properly support and align the suction and discharge piping to prevent stress at pump connections. (*Figure 1*)
- Provide for adequate motor ventilation.
- Keep suction piping as short and direct as possible.
- Install the pump so that it is readily accessible for maintenance, inspection and cleaning.
- Ensure that any mounting structure is properly sized to support the weight of the pump.
- Consider local noise level regulations when installing the pump.
- Ensure that the pump motor type is suitable for the environment where the pump is to be operated. (Pumps intended for use in hazardous environments eg., explosive, corrosive, etc., must use a motor with the appropriate enclosure characteristics. Failure to use an appropriate motor type may result in serious damage and/or injury.)
- Install throttling valves in the discharge piping to control the pump performance. Do not install throttling valves in the suction piping.
- Check valves in the discharge line should be a minimum of 5 ft. away from the pump outlet (*Figure 1*).
- In applications where the pump may lose its prime when shut off, an elbow or foot valve (or check valve) may be installed at the piping inlet to prevent the liquid from draining out of the suction line. See *Figure 2*.

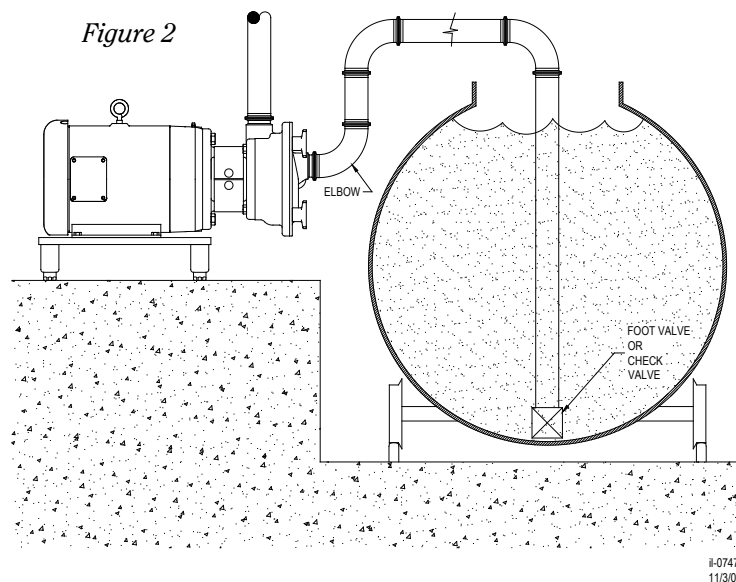
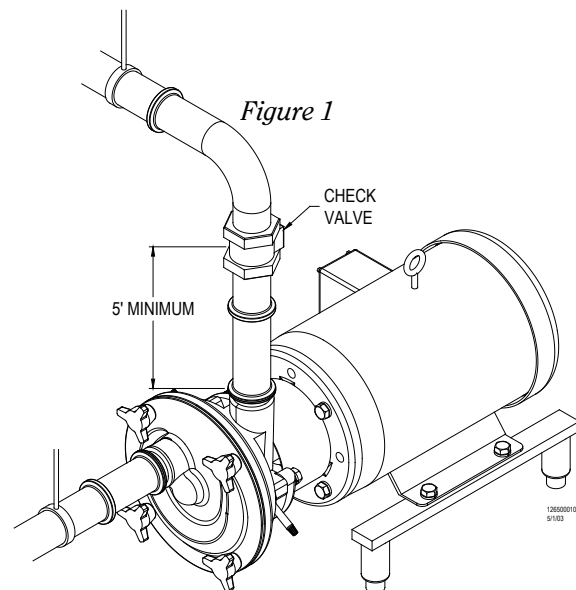

## ELECTRICAL INSTALLATION

- We use standard duty TEFC motors unless otherwise specified. Other motor options are available such as: washdown, flameproof, explosion-proof, hostile duty or chemical duty.
- Check pump for proper rotation. The shaft should rotate clockwise when viewing the motor fan.
- Note that a change in operating conditions (for example, higher viscosity, higher specific gravity, lower head losses) may change the load requirements on the motor. If you have a question regarding the power requirements for your application, please contact your local Fristam distributor or Fristam Pumps, Inc. for technical assistance.

## INSTALLATION OF WATER FLUSH FOR DOUBLE MECHANICAL SEAL

- Set up the water flush for the double mechanical seal (if installed). As shown in *Figure 3*. The seal flush water should be supplied at a maximum flow rate of 1-2 gph (45.42 lph) at a maximum pressure of 5 psi (.35 bar). *Excessive flow/pressure through the seal flush will cause excessive wear and shorten seal life.*
- It is desirable to have the flush water on the outlet side visible. This allows an easy check to see that the flush water is on and also if the seal is functioning properly. In a malfunctioning seal the flush water will disappear, become discolored or show an unusual increase in flow. If these conditions exist, check the seal and replace if necessary.

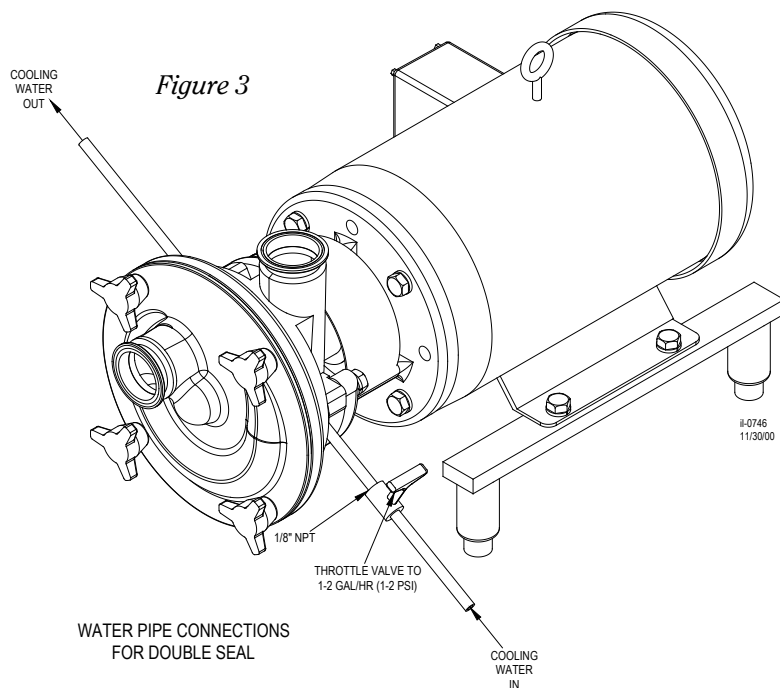

## PUMP OPERATIONS

### START-UP INSTRUCTIONS

- Remove any foreign matter in the pump or piping system before start-up. Do not use the pump to flush the system!
- Make sure the pump housing is filled with liquid before start-up.
- Avoid abrupt closure of valves. This can cause hydraulic shock which may cause severe damage to the pump and system.
- Maximum inlet pressure to the pump should not exceed 150 psi.

### SHUT-DOWN INSTRUCTIONS

- Shuff off the power supply to the pump.
- Close the shut-off valves in the suction and discharge piping.
- Draining and clean the pump.
- Protect the pump against dust, hear, moisture and impact damage.

## TROUBLESHOOTING

Fristam pumps are relatively maintenance free, however, in the event that a problem does arise, the troubleshooting chart below should help you with most of your pump related problems. If a motor problem arises please contact your local motor repair representative.

This troubleshooting chart has been prepared assuming that the pump installed is suitable for the application. Symptoms of cavitation can result when a pump is not properly applied. Examples of these symptoms are noisy operation, insufficient discharge, and vibration. If these conditions are present, check the system and re-evaluate the application. If you need assistance, contact Fristam Pumps at 1-800-841-5001 or 608-831-5001.

<b>PROBLEM</b>	<b>POSSIBLE CAUSE OF TROUBLE</b>
	(see following pages)
Pump does not deliver liquid	1, 2, 6, 7, 9, 10, 13, 15, 27, 28
Not enough capacity delivered	2, 3, 7, 10, 13, 15, 19, 20, 27
Pump loses prime after starting	2, 3, 6
Pump requires too much power	8, 11, 12, 15, 18, 19, 23
Leaking seal	5, 17, 22, 23, 24, 25
Seal fails prematurely	4, 6, 17, 19, 22, 23, 24, 25
Pump vibrates or is noisy	2, 11, 14, 15, 16, 17, 18, 19, 20, 26, 27, 29
Motor bearings fail prematurely	14, 17, 19, 26, 27
Pump overheats and seizes	1, 14, 18, 19, 26
Pump head leaking	21
<b>POSSIBLE CAUSE OF SUCTION PROBLEMS</b>	<b>POSSIBLE SOLUTIONS</b>
1. Pump inlet is not flooded	1a) Adjust piping so the pump inlet is flooded 1b) Install a foot valve to keep liquid in the suction piping
2. NPSHA is not sufficient	2a) Raise the level of liquid on the inlet side of the pump or lower the pump 2b) Use a larger pipe on the inlet side of the pump 2c) Eliminate restrictions in suction line where possible 2d) Check the inlet pipe for obstructions 2e) Shorten the inlet piping, move pump 2f) Lower the temperature of the liquid
3. Air entering the pump through the seal area	3. Check seal for proper installation, replace seal if defective

- 4. Seal flush water not on (double seal only)
- 5. Seal water flush pressure too high (double seal only)
- 6. Not enough liquid is retained in the pump housing

- 4. Turn on water to seal flush
- 5. Adjust water flow to seal flush to 10-12 gph at 1-2 psi
- 6. Install an elbow on the pump inlet

**POSSIBLE CAUSE OF MECHANICAL PROBLEMS**

---

- 7. Drive speed too low
- 8. Drive speed too high
- 9. Direction of shaft rotation is incorrect
- 10. Total head of system is higher than design head of pump
- 11. Total head of system is lower than pump design head
- 12. Specific gravity of liquid greater than expected
- 13. Viscosity of liquid is greater than expected
- 14. Operation is at a very low capacity for the pump model chosen
- 15. Foreign matter in pump
- 16. Pump foundation not rigid
- 17. Bent shaft
- 18. Impeller rubbing on pump housing or cover
- 19. Motor worn or damaged
- 20. Pump damaged
- 21. Cover gasket defective, permitting leakage
- 22. Shaft worn or scored
- 23. Seal improperly installed

- 7. Have a qualified person check that the power supplied matches the power of the drive
- 8. Have a qualified person check that the power supplied matches the power of the drive
- 9. Reverse rotation
- 10a) Check for restrictions in the piping
- 10b) Use larger diameter pipe
- 10c) Check application with Fristam Pumps
- 11a) Install throttling valve in discharge line
- 11b) Check with Fristam Pumps
- 12. Use larger motor, check application with Fristam Pumps
- 13a) Increase piping diameter and eliminate restrictions
- 13b) A larger drive or pump may be required, check application with Fristam Pumps
- 14. Check application with Fristam Pumps
- 15. Remove pump cover and clear foreign matter
- 16. Provide firmer foundation for the pump
- 17. Replace shaft (see pages 20-21 for directions)
- 18a) Check the impeller gap
- 18b) Replace defective components
- 18c) Make sure impeller nut is tightened properly
- 19. Take motor to authorized service center
- 20. Remove pump cover and inspect for damage. Replace defective parts
- 21. Replace cover gasket
- 22. Replace pump shaft
- 23. Check seal installation, replace defective components

- |   |   |
|---|---|
| 24. Type of seal incorrect for operating conditions   | 24. Replace seal with correct type of seal, check with your local representative or Fristam Pumps |
| 25. Dirt or grit in seal flush liquid leading to scoring of shaft or seal surfaces (double seal only) | 25. Use clean source of water for seal flush  |
| 26. Lack of lubrication in motor bearing  | 26. Lubricate motor bearings  |
| 27. Piping is obstructed  | 27. Remove obstruction in pipe, check for closed valve  |
| 28. Power is not being supplied   | 28. Have qualified person check electrical connections  |
| 29. Piping is being supported by the pump   | 29. Support the piping independently from the pump  |

Архангельск (8182)63-90-72  
Астана (7172)727-132  
Астрахань (8512)99-46-04  
Барнаул (3852)73-04-60  
Белгород (4722)40-23-64  
Брянск (4832)59-03-52  
Владивосток (423)249-28-31  
Волгоград (844)278-03-48  
Вологда (8172)26-41-59  
Воронеж (473)204-51-73  
Екатеринбург (343)384-55-89  
Иваново (4932)77-34-06

Ижевск (3412)26-03-58  
Иркутск (395)279-98-46  
Казань (843)206-01-48  
Калининград (4012)72-03-81  
Калуга (4842)92-23-67  
Кемерово (3842)65-04-62  
Киров (8332)68-02-04  
Краснодар (861)203-40-90  
Красноярск (391)204-63-61  
Курск (4712)77-13-04  
Липецк (4742)52-20-81  
Киргизия (996)312-96-26-47

Магнитогорск (3519)55-03-13  
Москва (495)268-04-70  
Мурманск (8152)59-64-93  
Набережные Челны (8552)20-53-41  
Нижегород (831)429-08-12  
Новокузнецк (3843)20-46-81  
Новосибирск (383)227-86-73  
Омск (3812)21-46-40  
Орел (4862)44-53-42  
Оренбург (3532)37-68-04  
Пенза (8412)22-31-16  
Казахстан (772)734-952-31

Пермь (342)205-81-47  
Ростов-на-Дону (863)308-18-15  
Рязань (4912)46-61-64  
Самара (846)206-03-16  
Санкт-Петербург (812)309-46-40  
Саратов (845)249-38-78  
Севастополь (8692)22-31-93  
Симферополь (3652)67-13-56  
Смоленск (4812)29-41-54  
Сочи (862)225-72-31  
Ставрополь (8652)20-65-13  
Таджикистан (992)427-82-92-69

Сургут (3462)77-98-35  
Тверь (4822)63-31-35  
Томск (3822)98-41-53  
Тула (4872)74-02-29  
Тюмень (3452)66-21-18  
Ульяновск (8422)24-23-59  
Уфа (347)229-48-12  
Хабаровск (4212)92-98-04  
Челябинск (351)202-03-61  
Череповец (8202)49-02-64  
Ярославль (4852)69-52-93

<https://fristam.nt-rt.ru/> || [fmg@nt-rt.ru](mailto:fmg@nt-rt.ru)