

Original Operating Manual
Mounting instructions

Centrifugal pump FPC series KF

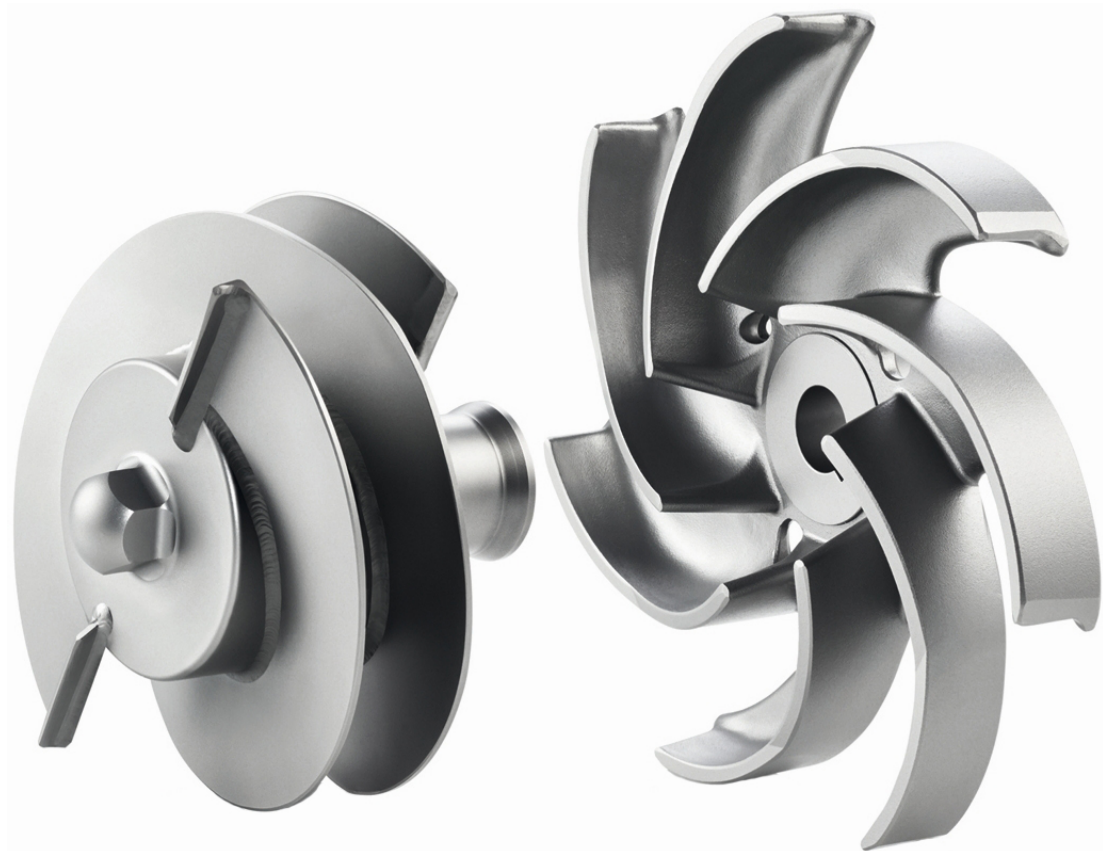

Архангельск (8182)63-90-72
Астана (7172)727-132
Астрахань (8512)99-46-04
Барнаул (3852)73-04-60
Белгород (4722)40-23-64
Брянск (4832)59-03-52
Владивосток (423)249-28-31
Волгоград (844)278-03-48
Вологда (8172)26-41-59
Воронеж (473)204-51-73
Екатеринбург (343)384-55-89
Иваново (4932)77-34-06

Ижевск (3412)26-03-58
Иркутск (395)279-98-46
Казань (843)206-01-48
Калининград (4012)72-03-81
Калуга (4842)92-23-67
Кемерово (3842)65-04-62
Киров (8332)68-02-04
Краснодар (861)203-40-90
Красноярск (391)204-63-61
Курск (4712)77-13-04
Липецк (4742)52-20-81
Киргизия (996)312-96-26-47

Магнитогорск (3519)55-03-13
Москва (495)268-04-70
Мурманск (8152)59-64-93
Набережные Челны (8552)20-53-41
Нижний Новгород (831)429-08-12
Новокузнецк (3843)20-46-81
Новосибирск (383)227-86-73
Омск (3812)21-46-40
Орел (4862)44-53-42
Оренбург (3532)37-68-04
Пенза (8412)22-31-16
Казахстан (772)734-952-31

Пермь (342)205-81-47
Ростов-на-Дону (863)308-18-15
Рязань (4912)46-61-64
Самара (846)206-03-16
Санкт-Петербург (812)309-46-40
Саратов (845)249-38-78
Севастополь (8692)22-31-93
Симферополь (3652)67-13-56
Смоленск (4812)29-41-54
Сочи (862)225-72-31
Ставрополь (8652)20-65-13
Таджикистан (992)427-82-92-69

Сургут (3462)77-98-35
Тверь (4822)63-31-35
Томск (3822)98-41-53
Тула (4872)74-02-29
Тюмень (3452)66-21-18
Ульяновск (8422)24-23-59
Уфа (347)229-48-12
Хабаровск (4212)92-98-04
Челябинск (351)202-03-61
Череповец (8202)49-02-64
Ярославль (4852)69-52-93

Contents

1	Introduction	5	7	Operation	13
1.1	Foreword.....	5	7.1	Safety instructions.....	13
1.2	Manufacturer	5	7.2	Start operation.....	14
1.3	Scope of delivery	5	7.3	Monitor the pump operation	14
1.4	Pump without motor (option).....	5	7.4	Stop operation.....	14
1.5	Scope of documentation	5	7.5	Decommission pump.....	14
1.6	About this manual	5	7.6	Cleaning during operation.....	14
2	Safety.....	6	8	Malfunctions	15
2.1	Basic safety instruction	6	8.1	Safety instructions.....	15
2.2	Proper use.....	6			
2.3	Predictable misuse	6	9	Maintenance.....	15
2.4	Warning and information signs	6	9.1	Safety instructions.....	15
2.5	Noise emission	7	9.2	Spare parts	15
2.6	Disposal	7	9.3	Check the sealing or quenching fluid line (optional)	15
3	Layout and function	8	9.4	Lubricate motor bearing.....	15
3.1	Principal design	8	9.5	Lubricate shaft bearing	15
3.2	Models.....	9	9.6	Change motor.....	16
3.3	Pump designation key	9	9.7	Replace shaft seal	16
3.4	Versions	9	9.8	Dismantle the pump head	17
4	Transport.....	10	9.9	Check clearances	17
4.1	Transport.....	10	9.10	Mount the pump head	18
			9.11	Model FPC...V: Mount and align the pump shaft.....	22
5	Storage	11	10	Appendix 1	23
5.1	Safety instructions	11	10.1	Technical data.....	23
5.2	Storage conditions	11	10.2	Maintenance intervals ¹	24
5.3	Storage.....	11	10.3	Malfunction table	25
5.4	Re-commissioning.....	11	10.4	Numbers in sectional drawings	27
			10.5	EC Declaration of Conformity.....	28
			10.6	EG Declaration of Incorporation	28
6	Installation	11	11	Appendix 2 – Mounting instructions (Option).....	29
6.1	Safety instructions	11	11.1	Safety instructions.....	29
6.2	Installation site.....	11	11.2	Application.....	29
6.3	Prevention of noise and vibration	12	11.3	Type plate.....	29
6.4	Attach the pump	12	11.4	Transport without motor.....	29
6.5	Electrical connection	13			
6.6	Connect the sealing or quenching fluid line (optional)	13			
6.7	Cleaning	13			

1 Introduction

1.1 Foreword

This operation manual describes all sizes, models and versions of the FPC centrifugal pumps.

Please refer to the type plate on your pump and to the "Order-related documents" in the enclosed documents for the model, size and version of your pump.

1.2 Manufacturer

FRISTAM Pumpen KG (GmbH & Co.)

Kurt-A.-Körber-Chaussee 55

21033 Hamburg

GERMANY

Telephone: +49 40/7 25 56-0

Fax: +49 40/7 25 56-166

E-mail: info@fristam.de

1.3 Scope of delivery

The delivery includes:

- Pump with motor = pump unit
optional: without motor
- Pipe connection covers
- Optional: Assembly kit
- *Fristam* accessories, if applicable
- Documentation
- ▶ Check the delivery for completeness and transport damage. Inform *Fristam* immediately in case of irregularities.

1.4 Pump without motor (option)

The pump can optionally be delivered without a motor. In this case, continue reading up to and including Section 3 "Layout and function", and then continue with Section 11 "Appendix 2 – Mounting instructions (Option)", page 29.

1.5 Scope of documentation

The documentation includes:

- **This operating manual**
 - Appendix 1 with maintenance, lubrication and tightening torque tables.
 - Appendix 2 with mounting instructions.

– Enclosed documents:

- Order-related documents
- Subvendor documentation (motor, etc.)
- Documentation about *Fristam* accessories, if applicable
- Certificates (materials certificates, etc.), if applicable
- Declaration of Conformity or Declaration of Incorporation.

1.6 About this manual

Lists are indicated by dashes:

- Part 1
- Part 2

Tasks that must be completed in a specific sequence are numbered:

1. Switch on machine.
2. Switch off machine.

Tasks that do not need to be completed in a specific order are preceded by triangles:

- ▶ Task
- ▶ Task

1.6.1 Safety instructions

⚠ DANGER

A safety instruction with the signal word "Danger" warns of dangers to persons that can result in death or serious injury.

⚠ WARNING

A safety instruction with the signal word "Warning" warns of dangers to persons that may result in death or serious injury.

⚠ CAUTION

A safety instruction with the signal word "Caution" warns of dangers to persons that may result in minor or moderate injury.

ATTENTION

A safety instruction with the signal word "Attention" warns of damage to property.

2 Safety

2.1 Basic safety instruction

- ▶ Read this operating manual fully before using the pump and keep it available at the pump installation site.
- ▶ Comply with all applicable statutory regulations in the country of use and the internal working and safety regulations.
- ▶ All work described here must be carried out by qualified specialist technicians and with due care.
- ▶ Danger of contamination: Comply with statutory and operational safety regulations when transporting hazardous conveying media.

2.2 Proper use

The FPC centrifugal pumps are designed for application in the food industry, in the pharmaceutical and biotechnology sector as well as in CIP process engineering.

The FPC centrifugal pumps are normally used as CIP return flow pumps, for draining tanks, for conveying gaseous media, but also as product pumps. It is possible to evacuate pipes on the suction side with these centrifugal pumps.

Each pump is designed in accordance with customer requirements. The sealing material has been specifically selected for the respective conveying medium. Only the explicit pumping medium for which the pump was designed may be conveyed with the pump (see "Order-related documents" in the enclosed documents).

The FPC centrifugal pumps are designed for operation with a speed of 2900 rpm and/or 3500 rpm. A lower speed deteriorates the suction behavior and thus influences the pump behavior.

2.3 Predictable misuse

The standard version of FPC centrifugal pumps may not be used in an explosive atmosphere. For such purposes, we offer special explosion-proof versions.

The conveying of inappropriate conveying media can destroy the pump.

The standard pump units by *Fristam* are described in this operation manual. The operator is responsible for operation with regards to exceptions and the installation of extras.

Modifications and changes to the pump are only permitted after consultation with *Fristam*.

2.4 Warning and information signs

- ▶ Never remove or change the warning and information signs attached the pump.
- ▶ Damaged or lost signs must be replaced immediately true to the original.

2.4.1 Direction of rotation



Fig. 1 Impeller direction of rotation sign

This sign shows the impeller's direction of rotation. The sign is attached to the pump.

2.4.2 Hot surface



Fig. 2 Safety label: "Hot surface"

This safety sign indicates that parts may become hot during pump operation or that hot conveying media may be conveyed. The pump may only be touched with suitable protective gloves.

2.4.3 No dry running

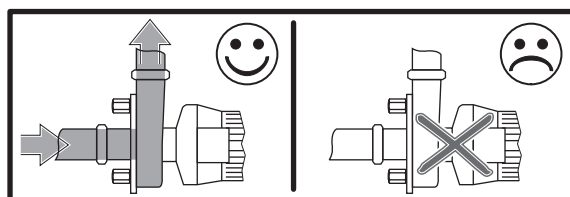

Fig. 3 Safety label: "No dry running"

This sign indicates that the pump must not be run dry under any circumstances. Conveying medium must always be present in the suction line and the pump when the pump is actuated. Otherwise the pump will be damaged.

2.4.4 Type plate

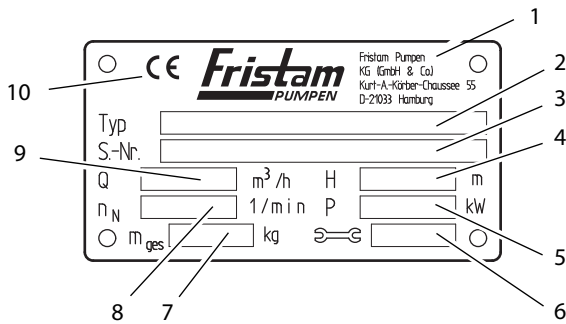

Fig. 4 Type plate for the pump unit

1	Manufacturer
2	Type: Pump series, size, design, version
3	S. no.: Serial number of the pump
4	H: Static head [m]
5	P: Motor power [kW]
6	Year of manufacture
7	mtot: Mass (total) [kg]
8	n_N : Rated speed [rpm]
9	Q: Flow rate [m^3/h]
10	CE label

2.5 Noise emission

- ▶ Adhere to the applicable statutory regulations for noise emissions. For the sound emission values of the pump, see Section 10.1 "Technical data", page 23.

⚠ CAUTION

Noise emission when pump is running

Damage to hearing

- ▶ Hearing protection must be worn when using pumps whose sound level is higher than 80 dB (A).

2.6 Disposal

2.6.1 Disposal of transport packaging

- ▶ Recycle transport packaging as recycling material.

2.6.2 Model KF: Disposal of lubricants

- ▶ Dispose of greased components and grease in accordance with the applicable environmental regulations.

2.6.3 Disposal of pump

1. Carefully clean the pump. Dispose of all residues in accordance with the applicable environmental regulations.
2. Dismantle pump into its individual components.
3. Dispose of the pump components in accordance with the applicable environmental regulations.

2.6.4 Disposal of electrical and electronic scrap

- ▶ Dispose of electrical and electronic scrap in accordance with the applicable environmental regulations.

3 Layout and function

3.1 Principal design

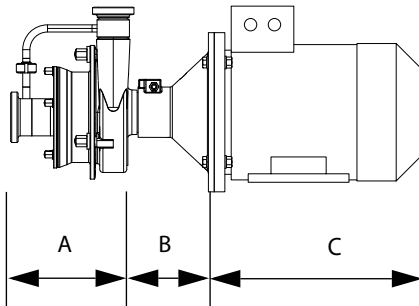

Fig. 5 Example of the principle layout of the pumps

A	Pump head
B	Lantern
C	Electric motor

3.1.1 Pump head (A)

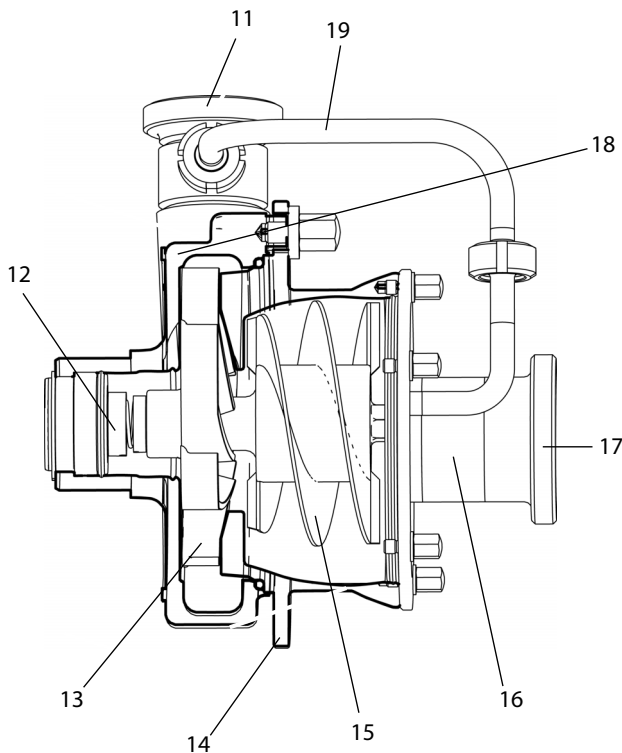

Fig. 6 Pump head

11	Pressure line connection
12	Shaft seal
13	Impeller
14	Pump cover
15	Rotor
16	Rotor cover
17	Suction line connection
18	Pump casing
19	Return line

Shaft seal (12)

The pump is available with two different shaft seal types:

- Single shaft seal
- Double shaft seal

For double shaft seals, the pump casing must feature two additional connections for the sealing liquid. These connections are not shown in the figures below.

3.1.2 Lantern (B) and electric motor (C)

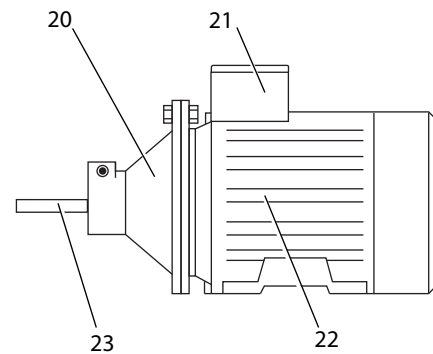

Fig. 7 Lantern and electric motor

20	Lantern
21	Electric power connection
22	Electric motor
23	Pump shaft

Lantern (20)

The lantern connects the pump casing with the motor. Two versions are possible, depending on the pump size:

- The pump casing is screwed to the lantern by means of a flange connection.
- The pump casing is inserted into the lantern and clamp-fitted.

Models with lanterns:

- FPC...V
- KF
An additional bearing for the pump shaft is fitted inside the lantern with base.

Electric motor (22)

The following motor types can be mounted:

- IEC standard motor with A-sided fixed bearing (drive side) with key and shaft pin in models:
 - IM B5: Model with flange
 - IM B3/B5: Model with flange and base

With the IEC standard motor, a *Fristam* pump shaft is clamped on the motor shaft pin.

3.2 Models

The model is stated on the type plate. See *Section 2.4.4 "Type plate", page 7.*

The following models are depicted in this manual:

- lantern clamp-fixed,
- without enclosure, see *Section 3.4 "Versions", page 9.*

3.2.1 Model FPC...V

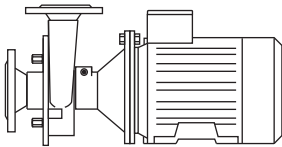

Fig. 8 Model FPC...V

Motor: IEC standard motor, model B3/B5

Layout: with lantern

3.2.2 Model KF

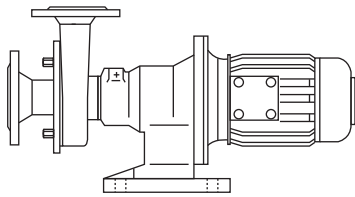

Fig. 9 Model KF

Motor: IEC standard motor, model B5

Layout: Compact bearing holder with base

3.3 Pump designation key

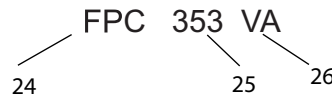

Fig. 10 Example of type designation

24	Pump type
25	Pump size
26	Symbol 1

(24) Pump type

FPC...V extended insert shaft as pump shaft

(26) Additional characters 1

A, B, C, D Versions see *Section 3.4 "Versions", page 9:*

KF Compact bearing holder with base

V Stainless steel lantern, double shaft seal, \varnothing 75mm on lantern neck

3.4 Versions

Version	Enclosure	Spherical cap bases	Motor base
A	with	with	without
B	without	without	with
C	without	with	without
D	with	without	with

Table 1 Versions

Note: In case of delivery of the pump without motor (optional), first read *Section "Appendix 2 – Mounting instructions (Option)" on page 29.*

4 Transport

4.1 Transport

All transport tasks must be carried out by trained personnel.

The pump can be transported by forklift truck or by crane.

Always transport the pump in its installation position.

4.1.1 Safety instructions

- ▶ Risk of injury from falling or unsecured components.
 - Only use suitable transport equipment and hoists. For details about the weight of the pump, see type plate of the pump and in the “Order-related documents” in the enclosed documents.
 - Prior to transport, secure the pump against falling. Secure it to the pallet, using securing straps or screws.
 - Do not leave the pump in an suspended position for longer than is necessary.
- ▶ Damage to the pump due to contamination, impacts or moisture.
 - Remove the protective foil only immediately prior to installation.
 - Only remove the pipe connection seals immediately prior to connecting the pipes.

4.1.2 Transportation with forklift truck

Preparation

- ▶ Ensure that the pump is properly secured on the pallet.

Procedure

1. Pick up the pallet with the forks of the forklift truck.
2. Carefully transport the pallet to the intended location and lower it to the ground.

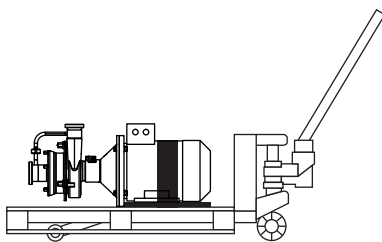

Fig. 11 Transport with lifting equipment

4.1.3 Transport with crane

⚠ WARNING

Falling parts

Death due to crushing, crushing of limbs, damage to property.

- ▶ Do not lift the pump by the eyelet bolts on the motor or the pump casing, as these bolts are not designed to carry the unit weight.
- ▶ Only use hoists designed for the total weight of the pump.
- ▶ Ensure that there are no persons standing below the suspended the pump.

⚠ WARNING

Swinging parts

Risk of crushing and serious injury.

- ▶ While transporting the pump, start and stop the crane without jerking.
- ▶ Ensure that there are no persons in the danger zone of the pump.

Auxiliary equipment

Hoists: tested round slings in accordance with DIN EN1492-1 and 1492-2.

Preparation

- ▶ Remove transport safeguards.

Procedure

1. Place round sling twice around the rear end of the motor. Do not place over the fan hood (see Fig. 12 Transport by crane).
2. Place the other end of the round sling between the lantern and the pump casing. Do not loop the round sling over sharp corners or edges.
3. Bring both slings to the crane hook and rotate them by 180° so that the slings cannot slip in the hook.
4. For models with double shaft seal:
 - Caution:** The round sling might push down on the sealing water tube. This might damage the double shaft seal.
 - ▶ Ensure that the round sling is placed around the sealing water tube.
5. Position the center of gravity so that the pump is lifted in a horizontal position.
6. Lift the pump.

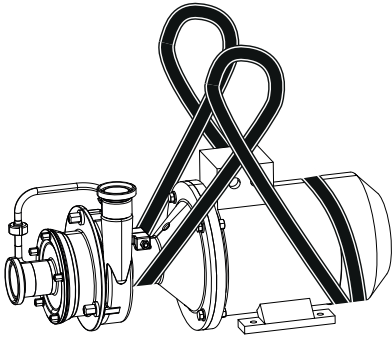

Fig. 12 Transport by crane

5 Storage

5.1 Safety instructions

- ▶ Corrosion: there is a risk of condensation under the tarpaulin, which can destroy the pump.
 - Provide adequate ventilation.

5.2 Storage conditions

- ▶ Store the pump as follows:
 - in dry room, with low air humidity
 - protected against frost and heat, where possible at 20 to 25 °C
 - in well ventilated area
 - free of dust

5.3 Storage

If the pump is to be stored for a period of more than six months, comply with the following:

- ▶ Remove the shaft seals and store them separately:
 - **For models with single shaft seal**
The rotor must be loosened to relax the seal and prevent conglutination of the polymers.
 - **For models with double shaft seal**
Completely dismantle shaft seal and store separately to prevent conglutination of the elastomers.

For information about the shaft seal, refer to the "Order-related documents".
- ▶ All moving pump parts must be rotated every three months.

5.3.1 Storage of elastomer parts

Storage conditions

- Storage temperature between +5 °C and +20 °C
- Relative air humidity below 70%
- Protected from direct sunlight
- Stored in a manner that does not cause deformation

5.4 Re-commissioning

- ▶ Prior to re-commissioning after prolonged storage, check the seals, bearings and lubrication.

6 Installation

6.1 Safety instructions

- ▶ Risk of injury from falling parts.
 - Wear safety footwear.
 - Observe the load-bearing capacity of the hoists and ensure proper attachment.
- ▶ Risk of injury from unstable installation.
 - Tighten screws with stated tightening torque (see Section 10.1.1 "Tightening torques for screws and nuts", page 23)
 - Use a torque wrench or an impact screwdriver with adjustable torque.
- ▶ Risk of damage to property from vibration in machines with spherical cap bases.
 - Use spherical cap discs.

6.2 Installation site

The installation site for pumps with standard equipment must meet the following conditions:

- Non-explosive atmosphere.
- Dust-free environment.
- Ambient temperature: –20 °C to +40 °C
- Humidity and salt content of the ambient air: see the documentation of the motor suppliers. This is included in the enclosed documents.
- Foundation of adequate dimensions for the pump weight.
- Horizontal and level installation surface. Adequate strength of surface for the pump weight.
- Sufficient space for maintenance work also required.
- Sufficient air supply for motor cooling.

6.3 Prevention of noise and vibration

6.3.1 Primary measures

- ▶ Operate pump within optimum operating range.
 - Do not underload the pump. Avoid excessive throttling. Only operate the pump with a low flow rate, if this is necessary for regulating purposes.
 - Do not operate the pump with very high flow rates. If necessary, install a flow limiter in the pressure line.
 - Operate pump without cavitation (see Section 6.4.1 "Install piping", page 12).
- ▶ De-couple the suction and pressure lines from vibrating parts.
 - Support the lines.
 - Align the lines.
 - Use vibration insulation elements.

6.3.2 Secondary measures

- ▶ Implement structural measures, such as:
 - Sound-proof cladding
 - Encasing of pump

6.4 Attach the pump

Models FPC...V

- ▶ Versions A and C:
Install and align the pump on the spherical cap bearings.
- ▶ Versions B and D:
Screw the pump with the pump base to the foundation.

Model KF

- ▶ Versions A and C:
Install and align the pump on the spherical cap bearings.
- ▶ Versions B and D:
Screw compact bearing support to the foundation.

Mobile frame (optional)

1. Position the pump at its location of operation. Apply the brakes to the rollers (if available) or secure the mobile frame with chocks.
2. Connect the mobile frame to an earthing conductor to eliminate static charging.
3. Install hosepipes so that these cannot be damaged.

6.4.1 Install piping

- ▶ Install and connect the pipelines as follows:
 - Keep the pipeline friction loss as low as possible: avoid unnecessary valves, elbows, and abrupt pipe transitions.

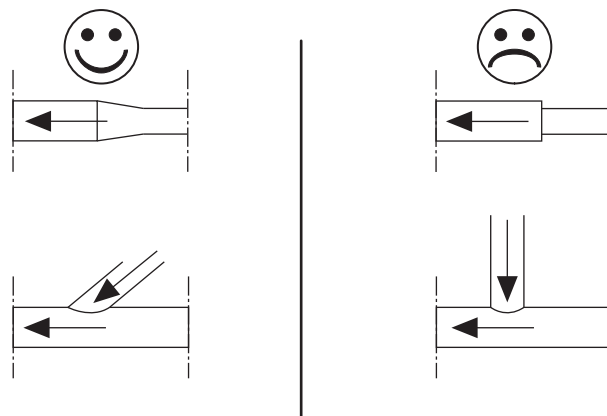

Fig. 13 Pipe transitions

- Install piping with an appropriate cross-section so that there is no unnecessary pressure loss or cavitation in the suction section so that the condition

$$NPSH_{\text{machine}} > NPSH_{\text{pump}}$$

is fulfilled.

This should be checked during the planning stage.

- Dimension the pipeline connections based on pressure, temperature and medium properties.
- Connect the pipelines without strain or pressure to the pump so that there is no stress or torsion at the pump.
- Fasten the piping with pipe clamps to ceilings, walls and the floor.
- Align the pipelines so that they are flush to the pump connections.

6.4.2 Installation of the piping when operating the pump as a self-priming pump

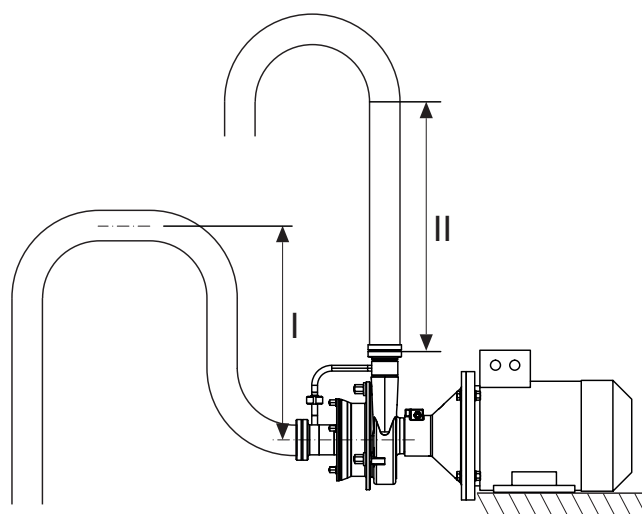

Fig. 14 Installation of suction and pressure line

If the pump is to be operated as a self-priming pump (evacuation of a negative suction-side pipe), the pipe requires a fluid feed Table 2 on page 13. Lay out the suction and pressure line as shown to ensure that the fluid remains in the pump and does not drain through the pipe. The pressure socket must always be aligned vertically upward.

Pump size	Dimension I in m	Dimension II in m	Fluid level in I
3531/3532	> 0.2	> 1.5	3.5
3541/3542	> 0.2	> 1.5	4.5

Table 2 Installation of the pipes

6.5 Electrical connection

The electrical connection must be installed by a qualified electrician.

1. Observe the connection rating on the motor type plate. The specified voltage must not be exceeded.
2. Connect the motor according to the circuit diagram in the terminal box of the motor.
3. Protect the cable glands against moisture.
4. Turn on the motor for 2 to 3 seconds and low speed. Compare the actual direction of rotation of the motor fan impeller with the arrow on the pump head.
5. If necessary, switch the poles.

6.6 Connect the sealing or quenching fluid line (optional)

In versions with double shaft seal, the seal chamber must be flushed with a sealing or quenching liquid.

- ▶ Use a suitable medium, such as water, for this purpose.

6.6.1 Installing the pipelines

1. Install and seal the supplied flushing tubes.
2. As a standard, the feed line should be fitted at the **bottom** of the shaft seal.
3. As a standard, the return line should be fitted at the **top** of the shaft seal.

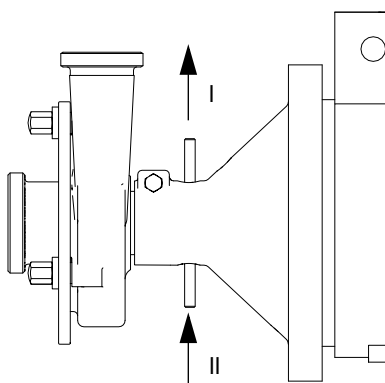

Fig. 15 Installing the pipelines

I	Return line
II	Inlet

4. Install the following valves into the pipelines:
 - Install the sight glass in the return line.

6.7 Cleaning

To clean the machine use a detergent that conforms to the hygiene requirements for the respective medium.

1. Before sealing the pump, ensure that there are no foreign substances inside the pump and the pipelines.
2. Seal the pump.
3. Connect the pipelines.
4. Before commissioning the machine, clean the pump and the pipeline system thoroughly.

7 Operation

7.1 Safety instructions

- ▶ Risk of injury from burns: if the pump is used for the conveying of a hot medium, it can become very hot. Before touching the pump, check its temperature.
- ▶ Noise emission: the A-rated sound level of the pump can exceed 80 dB (A). Always wear hearing protection when in the vicinity of the running pump.
- ▶ Risk of bursting: if the permissible pressure or temperature range is exceeded, the pump might burst or starts leaking. Observe the pressure and temperature range of the pump (see "Order-related documents" in the enclosed documents).
- ▶ Risk of bursting: in the event of a fire, the use of cold extinguishing agents can cause the pump to burst. Do not cool the pump when extinguishing, unless necessary.
- ▶ Pump is running in reverse, despite emergency stop: in the event of an emergency stop, the pump might run in reverse, due to the medium pressure in the pressure line. If necessary, install a check valve in the pressure line.
- ▶ Reverse running of the pump destroys the shaft seal. Reverse running of the pump destroys the springs in the shaft seal. In addition, reverse running detaches the rotor, which may result in damage to the entire pump head. Always operate pump in the direction of rotation. See Section 2.4.1 "Direction of rotation", page 6.

7.2 Start operation

ATTENTION

Damage to the shaft seals

Running the pump without medium results in damage to the mechanical seal.

- ▶ Ensure that there is always sufficient medium in the pump (fill level at top edge at the outlet side) prior to and during operation.

ATTENTION

Damage to double shaft seals

Running the pump without sealing liquid results in damage to the shaft seal.

Ensure that during operation:

- ▶ The sealing liquid flows with the necessary pressure through the double shaft seal.

The prescribed sealing fluid pressure is specified in the "Order-related documents" in the sectional drawing of the shaft seal. The "Order-related documents" are included in this operating manual.

- Negative pressure in the seal chamber is not allowed.

If no pressure is noted in the "Sectional drawing of the shaft seal", the following applies:

- A max. pressure of 0.2 bar is allowed for seals to which sealing fluid is applied without pressure or which are flushed.
- ▶ The temperature of the sealing liquid is maintained at $T < 70\text{ °C}$.

1. Open the valve in the suction line.
2. Close the valve in the pressure line.
3. Fill the pump and the suction line up to the top edge of the pump with medium. Allow any air bubbles to escape.
4. Switch on the motor. The pump conveys medium against the closed valve in the pressure line. This limits the start-up current.
5. Slowly open the valve in the pressure line and adjusting the working point.

7.3 Monitor the pump operation

During operation, pay attention to the following:

- ▶ **Damage to the shaft seal:** Regulation of the pump performance by means of the valve at the suction side can cause damage to the pump and the shaft seals. Only adjust the pump performance with the valve at the pressure side.
- ▶ **Damage to conveying medium:** If the valve in the pressure line is suddenly closed during operation, or is closed for a prolonged period of time, pressure blows might occur in the pump, damaging the pump and/or the medium. During

pump operation, do not close the valve in the pressure line suddenly or for prolonged periods.

- ▶ **Damage to pump:** Exceeding the rated pump rate can lead to damage to the pump and the shaft seals. Do not exceed the maximum speed of 3,500 rpm.
- ▶ **Damage to motor when operated with frequency inverter (FI):** If the speed is too low, the FI motors might become damaged from overheating. Observe the instructions in the motor manufacturer documentation appended to this document.

7.4 Stop operation

1. Switch off the motor.
2. Close the valve in the suction line to prevent the pump from running empty.
3. Close the valve in the pressure line.

7.5 Decommission pump

1. Switch off the motor.
2. Close the valve in the suction line.
3. Close the valve in the pressure line.
4. Disconnect the pump from the power supply.
5. Empty the pump.
6. Clean the pump.
7. Dry the pump.
8. Protect the interior of the pump against moisture, for example with silica gel.
9. Seal the pipe connections with caps to prevent dirt or foreign objects entering the pump.
10. For further steps, please refer to *Section 5 "Storage", page 11*.

7.6 Cleaning during operation

7.6.1 CIP method

The pumps of the FPC series are suited for CIP (Cleaning In Place). The following recommended values apply to CIP cleaning:

Sample cleaning sequence

1. Pre-rinse with water
2. Rinse with sodium dioxide (NaOH, see *Table 3 CIP cleaning*).
3. Intermediate rinse with water
4. Rinse with nitric acid (HNO₃, see *Table 3 CIP cleaning*).
5. Clear rinse with water

Medium	Process temperature [°C]
NaOH (ca. 1–2%)	80 – 85
HNO ₃ (approx. 1 %)	60 – 65

Table 3 CIP cleaning

The pump's differential pressure should be 2 – 3 bar to achieve sufficient flow speeds.

In case deviating values, contact *Fristam*.

7.6.2 SIP method

The pumps of the FPC series are only suited for SIP (Sterilisation In Place) after consultation with *Fristam*.

Suitability depends on the installed elastomers.

Process temperature maximum 145 °C.

Temperatures with ATEX may deviate, see additional ATEX operation manual "*Temperature application limit*".

8 Malfunctions

For malfunctions, possible causes and remedies, see *Section 10.3 "Malfunction table", page 25*.

8.1 Safety instructions

- ▶ Risk of injury from burns: if the pump is used for the conveying of a hot medium, it can become very hot. Before touching the pump, check the temperature.
- ▶ Pump is running in reverse, despite emergency stop: in the event of an emergency stop, the pump might run in reverse, due to the medium pressure in the pressure line. Install a non-return valve.

9 Maintenance

For maintenance intervals, see *page 24*.

9.1 Safety instructions

- ▶ Rotating parts: risk of injury. Prior to removing guard plates, switch the pump's motor off and secure it against restarting.
- ▶ Risk of injury from burns: If the pump is used for the conveying of a hot medium, it can become very hot. Before touching the pump, check its temperature.
- ▶ Electric shock: as liquids flow through the unit, components might become electrically charged. Connect the pipelines and the pump to an earthing conductor.
- ▶ Uncontrolled escaping of liquid: Before any maintenance and set-up work on the pump:

- Close the suction and pressure valves upstream and downstream of the pump.

- Close the sealing or quenching liquid line.

- ▶ Escaping liquids: Risk of corrosion and contamination. Before opening the pump casing, empty the pump.
- ▶ Stress fractures: Do not shock-cool the pump. Material damage through scratching of polished surfaces. For work on polished surfaces, use a socket wrench with copper insert.

9.2 Spare parts

- ▶ The use of spare parts that were not approved by *Fristam Pumpen KG (GMBH & Co.)* may lead to serious injury to persons and material damage. In case of questions concerning spare parts, contact *Fristam*.

- ▶ *Fristam* registers all delivered pumps. The following information is required when ordering spare parts from *Fristam*:

Serial number, see

- type plate or
- pump casing (stamped mark)

9.3 Check the sealing or quenching fluid line (optional)

For pumps equipped for "locking system" or "quenching system," the sealing liquid head must be checked daily.

- ▶ Measure the sealing liquid pressure and compare it with the prescribed value.

The stated value is contained in the "*Order-related documents*" on the "*Sectional drawing of the shaft seal*". The "*Order-related documents*" are enclosed to this operation manual.

- ▶ The sealing liquid in the pump is heated up by the hot conveying medium.

Make sure that the sealing liquid temperature of $T < 70\text{ °C}$ is maintained during operation.

9.4 Lubricate motor bearing

- ▶ Lubricate the motor bearing in accordance with the manufacturer's instructions (see "*Motor supplier documentation*").

9.5 Lubricate shaft bearing

9.5.1 Model FPC...V

The model FPC...V does not have an additional shaft bearing and must therefore not be lubricated.

9.5.2 Model KF

- ▶ Do not relubricate the grooved ball bearing, replace completely.

- With constant operating conditions, and increase of the power consumption, the noise level and/or the vibration indicates wear. In this case, exchange the deep groove ball bearing.

► Lubricate cylindrical roller bearing with bearing grease.

Model	Bearing grease quantity
KF 1	20 g
KF 2	40 g
KF 3	60 g

Table 4 Bearing grease quantities model KF

Preconditions

- Pump head is removed.
- Motor is dismantled.

Procedure

1. Dismantle bearing cap (29).
2. Push out pump shaft (27) with bearing to the motor side.

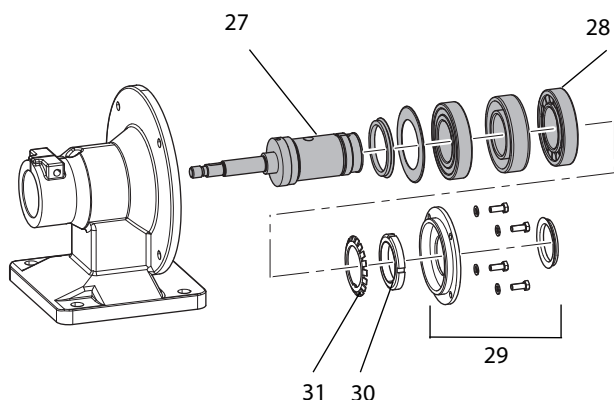

Fig. 16 Model KF, shaft bearing

3. Dismantle bearing nut (30) and retaining washer (31).
 4. Remove the outer race of the cylindrical roller bearing.
- Note: All components shown in grey in the above figure remain on the shaft.
5. Clean all parts and inspect them for damage. If necessary, replace damaged parts.
 6. Relubricate cylindrical roller bearing (27).

We recommended using: JAX Halo-Guard FG-2 bearing grease or alternatively a white NSF H1 grease. Alternatively, use an equivalent brand of lubricant of similar quality and viscosity.

See Table 4 Bearing grease quantities model KF.

7. Replace outer race on shaft.
8. Place retaining washer and bearing nut on the shaft and tighten bearing nut.

9. Push the pump shaft together with the bearing back into the lantern.
10. Mount bearing cap (29).

9.6 Change motor

IEC standard motor in FPC...V

1. Switch off the motor and secure it against restarting.
2. Dismantle the pump head (see Section 9.8 "Dismantle the pump head", page 17).
3. Remove lantern from motor.
4. Remove shaft.
5. Change motor.
6. Mount and align shaft (see Section 9.11 "Model FPC...V: Mount and align the pump shaft", page 22).
7. Mount lantern.
8. Flange connection only: check clearance if required (see Section 9.9 "Check clearances", page 17).
9. Change mechanical seal and mount pump head (see Section 9.10 "Mount the pump head", page 18).

IEC standard motor in model KF

1. Switch off the motor and secure it against restarting.
2. Remove the motor from the compact bearing holder with base.
3. Dispose of motor environmentally. See Section 2.6.4 "Disposal of electrical and electronic scrap", page 7.
4. Insert key of the old motor into the new motor.
5. Secure the motor to the compact bearing holder with base.

9.7 Replace shaft seal

The shaft seal must be replaced, if:

- Medium escapes from the pump at the atmosphere side.
- Sealing liquid contaminates the conveying medium.

Procedure

1. Dismantle the pump head (see Section 9.8 "Dismantle the pump head", page 17).
2. Change mechanical seal and mount pump head (see Section 9.10 "Mount the pump head", page 18). Perform the following steps, depending on the shaft seal type:
 - Pre-assemble the seals on the shaft.
 - Pre-assemble the pump casing.
 - Mount the lantern on the pump casing.
 - Mount the mechanical seal.
 - Mount the impeller.
 - Screw on the pump cover.

- ▶ Mount the rotor.
- ▶ Screw on the rotor cover.
- ▶ Mount the return line.

9.8 Dismantle the pump head

9.8.1 Preparation

1. Switch off the motor and secure it against restarting.
2. Close the valve in the pressure line.
3. Close the valve in the suction line.
4. Empty the pump completely.

9.8.2 Procedure

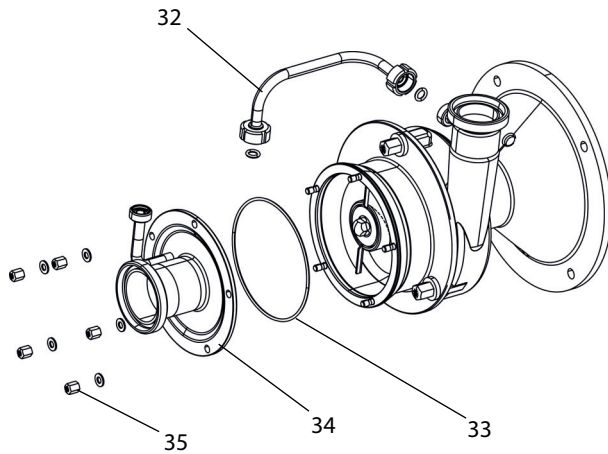

Fig. 17 Pump cover

1. Undo return line (32) between rotor cover (34) and casing.
2. Undo nuts (35) on pump cover.
3. Take off nuts, washers, rotor cover (34) and cover seal (33).

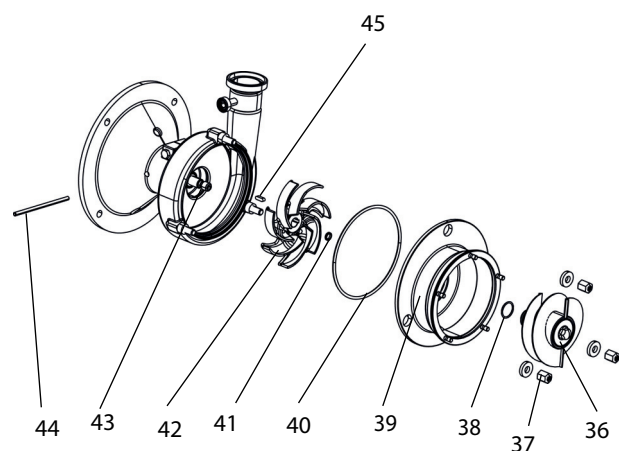

Fig. 18 Impeller

4. **WARNING:** Risk of injury when holding the rotor by hand to prevent it from rotating. Block shaft (43) through the boring in the lantern with a tool (44).
5. Undo rotor (36) and take off together with the O-ring (38).
6. Undo nuts (37) on pump cover.
7. Take off nuts, washers, pump cover (39) and cover seal (40).
8. Take snap ring (41), impeller (42) and key (45) off the shaft.
9. Only in pumps with double shaft seal: Remove the flush tubes for the sealing/quenching liquid.
10. Pull the pump head together with the pump-side shaft seal from the shaft, proceeding as following:
 - 10a. Version with clamp connection
 1. Loosen the clamp screw.
 2. Slightly widen the clamp connection with a wedge.
 3. Pull the pump casing from the clamp connection.
 - 10b. Version with flange connection
 1. Loosen and remove the connecting screws at the flange.
 2. Remove the pump casing.
11. Remove the shaft seal from the pump casing.

9.9 Check clearances

The position of the impeller is fixedly defined by the position of the shaft. The clearances are set by the position of the pump casing to the impeller.

Note: Refer to table 5 for the clearance.

Prerequisites

- Pump casing is permanently connected to lantern.
- Pump cover is removed.
- Impeller is placed and the rotor is tightened.

9.9.1 Measure the impeller-pump cover clearance

1. Measure the height of the pump cover (46) with vernier calipers.

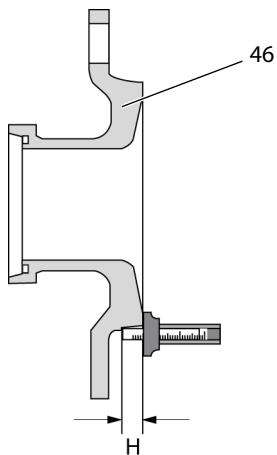

Fig. 19 Height

2. Measure the distance A from the pump casing (47) to the impeller (48) with vernier calipers, see Fig. "Distance" on page 18.

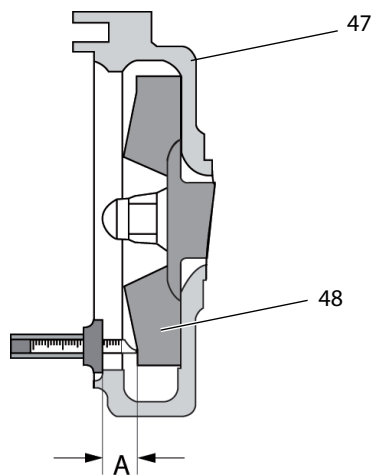

Fig. 20 Distance

3. Calculate the clearance (clearance = A - H).
4. Compare clearance with Table 5 "Standard clearance", page 18.

9.9.2 Measure the impeller-casing clearance

1. Measure the impeller/casing clearance with feeler gauge (Fig. 21 "Impeller-housing clearance", page 18).
2. Compare clearance with Table 5 "Standard clearance", page 18.

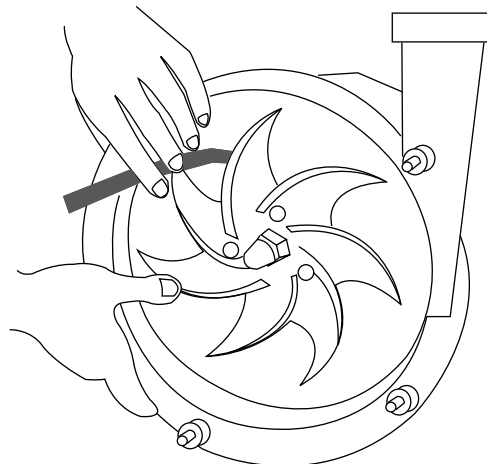

Fig. 21 Impeller-housing clearance

Pump size	Clearance in mm	
	Impeller/pump cover	Impeller/casing
3531/3532	0.5	1.5
3541/3542	1.0	1.1

Table 5 Standard clearance

9.10 Mount the pump head

The mounting of the pump depends on the respective size and model as well as on the respective shaft seal (see "Order-related documents") in the enclosed documents.

ATTENTION

Incorrect elastomers

Leakage at pump.

- ▶ Ensure that the elastomers are suitable for the conveying media properties. See "Order-related documents".

Preparation

- ▶ Clean all pump parts and inspect them for damage and proper fit.
- ▶ If required, rework or replace the pump parts.
- ▶ Perform the mounting procedure under clean conditions, carefully, and without applying little force. Otherwise the seals may be permanently deformed or break in some cases.
- ▶ Replace all O-rings.
- ▶ To reduce friction, wet the O-rings and sliding surface with water, alcohol or silicon grease.
- ▶ Clean the sealing faces of the mechanical seals with a degreasing agent, e.g. "OKS 2610 Universal Cleaner". Ensure that the seal faces are subsequently not contaminated with oil or grease. Do not touch them with your fingers.

Tip: To glue in bearings and bushings, we recommend using an adhesive such as "Euro Lock A64.80".

Tip: To secure the threaded pins, we recommend using an adhesive such as "Euro Lock A24.10".

9.10.1 Set the clearance for the flange connection

Note: In the case of pumps with flange connections, the clearance is set with shims. To find out the exact number and thickness of the required shims, the rotor, impeller and key must first be mounted as follows and then dismantled again.

1. Slide pump casing (49) and shims (50) over the shaft up to the flange (51) and screw on.

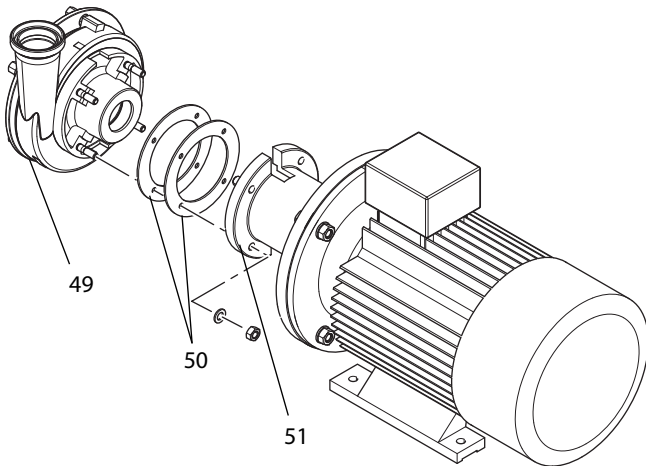

Fig. 22 Set the clearance for the flange connection

2. Slide driver onto the shaft.
3. Slide key and impeller onto the shaft.
4. Tighten the rotor.
5. Check clearances (see Section 9.9 "Check clearances", page 17).
6. Dismantle rotor, impeller and key.
7. Remove the pump casing.
8. If the clearance is not correct:
 - ▶ Set the clearance with suitable shims.

9.10.2 Mount seals

For details regarding the shaft seal installed in the pump, see "Order-related documents", sectional drawing and spare parts list.

The parts numbers in this section correspond to DIN 24250.

The mounting of standard shaft seals for the application cases A and B is described in the following. Your order-related version may deviate from this. In case of questions or for further information, contact Fristam.

Application case	Pump	Shaft seal	Sizes
A	FPC/FPC...V	single	350
B	FPC/FPC...V	double	350

Table 6 Standard shaft seals

Application case A

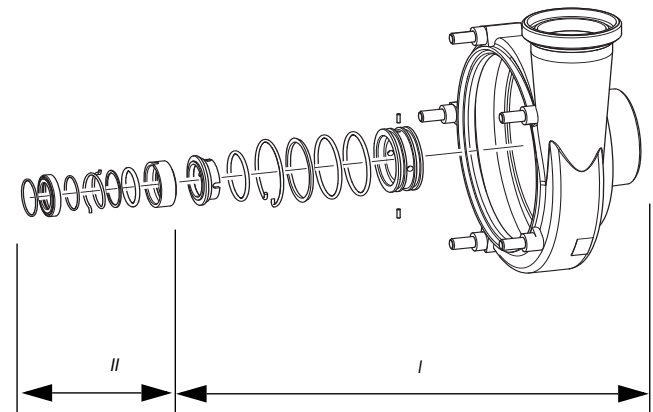

Fig. 23 Application case A

In the above figure, parts are grouped according to assembly steps:

I	Pre-assemble pump casing
II	Terminate the assembly on the shaft

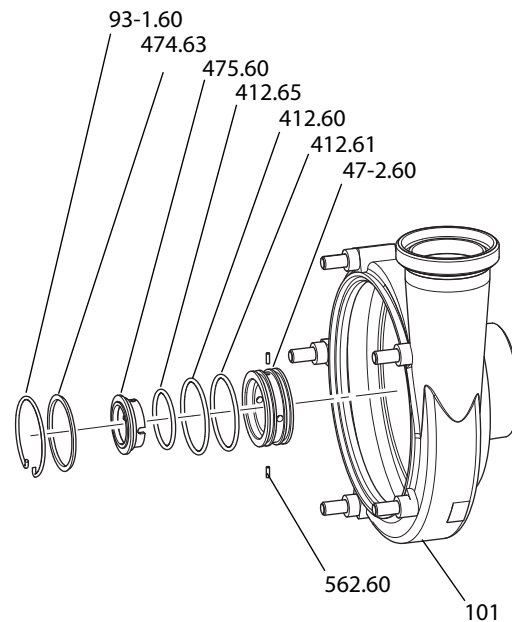

Fig. 24 Application case A, preassemble the pump casing

To preassemble the pump casing (I):

1. Glue in cylindrical pin (562.60) in the mechanical seal chamber (47-2.60) with a joint.

Note: Glue in cylindrical pins with adhesive in the mechanical seal chamber so that they do not contact the shaft in any case in assembled state. Please note that the cylindrical pin are completely inserted in the borings of the mating ring (475.60). If they are no borings in the mating ring, the cylindrical pins must be inserted in the notches of the mating ring (see "Sectional drawing of the shaft seal").

2. Fit mechanical seal chamber with O-rings (412.60), (412.61).

3. Insert the preassembled mechanical seal chamber into the pump casing (**101**).
4. Fit the pump casing with a thrust collar (**474.63**) and secure with a snap ring (**93-1.60**).

Now the pump casing is preassembled.

5. Fit the mating ring (**475.60**) with an O-ring (**412.65**).
6. Insert the mating ring into the mechanical seal chamber.

Note: Insert in such a way that the cylindrical pins of the mechanical seal chamber are inserted into the grooves of the mating ring.

Now the mechanical seal chamber is preassembled.

7. Mount pre-assembled pump casing (**101**) on shaft as described in Section 9.10.3 "Mount the pump casing", page 21.

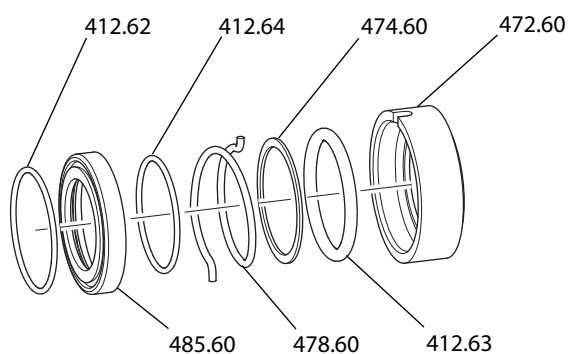

Fig. 25 Application case A, completing the installation on the shaft

To complete the assembly on the shaft (II):

8. Fit primary ring (**472.60**) with O-rings (**412.63**).
9. Fit driver (**485.60**) with O-rings (**412.62**) and (**412.64**).
10. Slide primary ring with thrust collar (**474.60**), spring (**478.60**) and driver onto the shaft. Let the edge of the spring snap into the primary ring.
11. Terminate assembly of the shaft seal by fitting the impeller, see Section 9.10.4 "Mount the impeller", page 21.
Note: Let the edge of the spring snap into the groove of the primary ring.
12. Terminate assembly of the shaft seal by fitting the impeller, see Section 9.10.4 "Mount the impeller", page 21.

Application case B

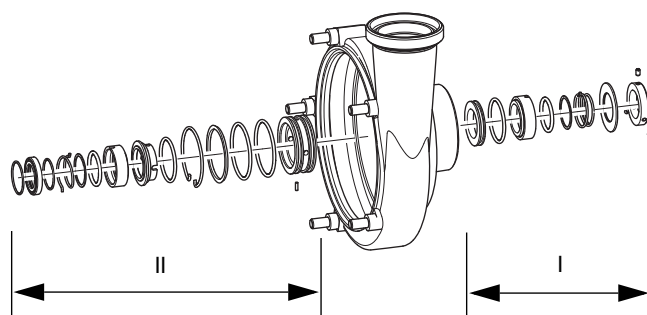

Fig. 26 Application case B

In the above figure, parts are grouped according to assembly steps:

I	Mount the shaft seal on the motor side on the shaft
II	Mount the shaft seal on the pump side on the shaft

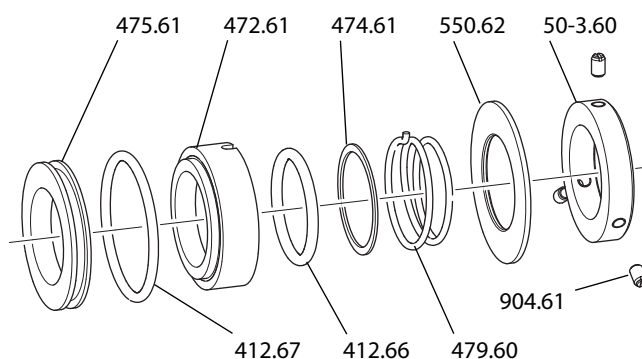

Fig. 27 Application case B, mounting the shaft seal on the motor side (I)

To install the shaft seal on the motor side (I):

1. Only with FPC...V: Fixate the collar (**50-3.60**) with set screws (**904.61**) on the shaft.
In doing so, fit the set screws with screw retainer. Position on the shaft: see "Sectional drawing of the shaft seal".
2. Slide washer (**550.62**) onto the shaft.
3. Fit primary ring (**472.61**) with O-ring (**412.66**).
4. Slide spring (**479.60**) with thrust collar (**474.61**), primary ring (**472.61**) onto the shaft. In doing so, let the edge of the spring snap into the groove of the primary ring.
5. For mounting the pump casing, see Section 9.10.3 "Mount the pump casing", page 21.
6. Insert O-ring (**412.67**) into the mating ring (**475.61**) and insert into the mechanical seal chamber (**47-2.60**).
The shaft seal has now been preassembled on the motor side. To install the shaft seal on the pump side (II):
7. To install the shaft seal on the pump side, proceed as described in Section "Application case A", page 19.

9.10.3 Mount the pump casing

Pump with flange connection

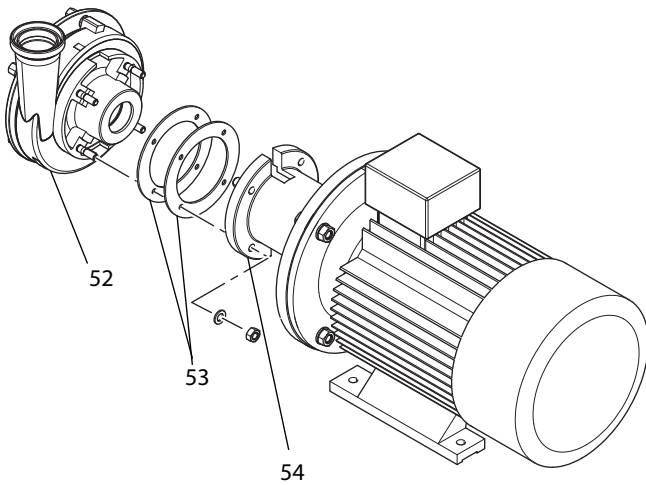

Fig. 28 Mount the pump casing with flange connection

- ▶ Slide preassembled pump casing (52) with shims (53) over the shaft up to the flange (54) and screw on (see Section 10.1 "Technical data", page 23).

Pump with clamp connection

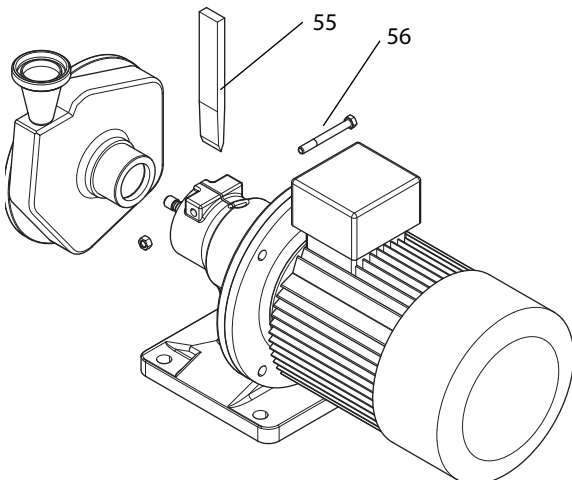

Fig. 29 Mount the pump casing with clamp connection

1. Slightly widen the clamp connection with a wedge (55).
2. Only with double shaft seal: slide motor side seal set onto the pump shaft.
3. Install the complete shaft seal casing with seals into the pump casing and secure against shifting.
4. Slide the pump casing over the pump shaft to the clamp connection and slightly tighten the clamp bolt (56).
5. Slide the pump-side seal set onto the shaft.
6. Insert key, slotted plastic retaining washer and impeller.
7. **Caution:** Risk of injury when holding the rotor by hand to prevent it from rotating. Block shaft through the boring in the lantern with a tool.

8. Insert O-ring into the rotor, block shaft against twisting and tighten rotor.

Thread	Tightening torque
M16	100 Nm

Table 7 Tightening torque for rotor

9. **Note:** The rotor may not be tightened with an impact screwdriver.

10. Set the clearance by shifting the pump head within the clamp connection (see Section 9.9 "Check clearances", page 17). In doing so, align the surface of the pressure socket horizontally (connection of pressure line).

11. Tighten clamp bolt (56):

	Thread	Tightening torque
Standard motor	M10	45 Nm
	M12	75 Nm

Table 8 Tightening torques for clamp connection

12. Continue with section Section 9.10.5 "Seal pump", page 22.

9.10.4 Mount the impeller

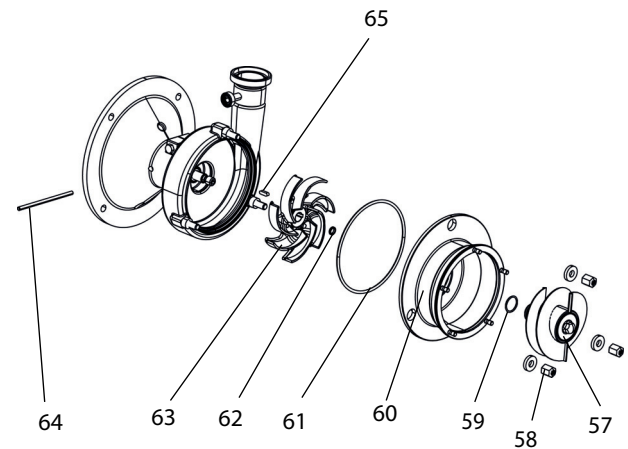

Fig. 30 Impeller mounting

1. Cut plastic retaining washer (62) open and insert into the shaft groove.
2. Slide key (65) and impeller (63) onto the shaft.
3. **Caution:** Risk of injury when holding the impeller by hand to prevent it from rotating.
 - ▶ Block impeller with a wooden wedge.
4. Fit pump cover (60) with O-ring (61) and screw onto casing with cap nuts (58).
5. **WARNING:** Risk of injury when holding the rotor by hand to prevent it from rotating. Block shaft through the boring in the lantern with a tool (64).
6. Twist rotor (57) with O-rings (59) onto the shaft and tighten (tightening torque = 100 Nm).

7. **Note:** The rotor may not be tightened with an impact screwdriver.
8. **Caution:** Remove the tool immediately after the assembly.

9.10.5 Seal pump

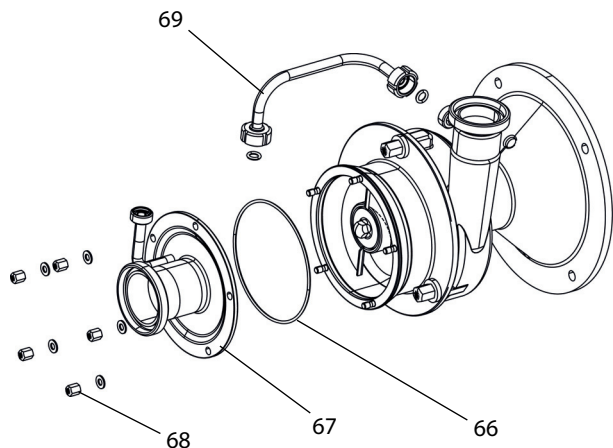

Fig. 31 Pump cover

1. Slide on rotor cover (67) with O-ring (66). Screw down nuts (68) with washers.
2. Connect return line (69) with O-rings between rotor cover and casing.

9.11 Model FPC...V: Mount and align the pump shaft

Note: After changing the IEC motor, the pump shaft must be installed and aligned.

CAUTION

Rotating parts

Bruising and severe injuries

- Switch off the motor and secure it against restarting.

1. Remove the key from the motor shaft pin.
2. For electric motors with a power of more than 30kW: insert the supplied half key.
3. degrease motor shaft pin and boring of the pump shaft with cleaning agent, e.g. "OKS 2610 Universal Cleaner".
4. Grind motor shaft pin and edges of the key groove with sandpaper to remove unevenness and burrs.
5. Coat motor shaft pin in the area of the shaft shoulder with sealing gel, e.g. "Stucarit 309".
6. Slide pump shaft with shrink ring onto the motor shaft pin up to the shaft shoulder.

7. Tighten the screws of the shrink ring crosswise:

Thread	Tightening torque
M5	6 Nm
M6	12 Nm
M8	30 Nm

8. Attach the dial gauge onto the pump shaft to check the run-out tolerance.

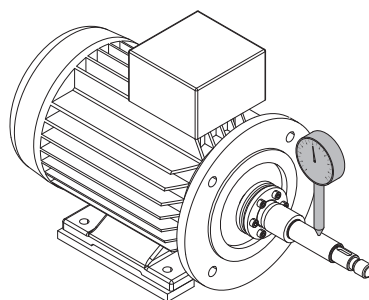

9. Check the runout of the pump shaft in dependence on the motor power.
 - Motor < 30 kW: max. runout tolerance = 0.06 mm
 - Motor > 30 kW: max. runout tolerance = 0.08 mm
10. If necessary, adjust runout of the pump shaft.

10 Appendix 1

10.1 Technical data

10.1.1 Tightening torques for screws and nuts

Material: Steel, strength class 8.8

Thread	M6	M8	M10	M12	M16	M20
Tightening torque [Nm]	11	27	54	93	230	464

Material: Stainless steel, strength class 70

Thread	M6	M8	M10	M12	M16	M20
Tightening torque [Nm]	7.4	17.5	36	62	150	303

Material: Stainless steel, strength class 80

Thread	M6	M8	M10	M12	M16	M20
Tightening torque [Nm]	10	24	49	80	203	393

10.1.2 Noise emission

Pump size	Sound level dB(A)
3532	79
3542	79

Table 9 Noise emission

The stated values apply for a 50 Hz mains connection and operation of the pump with the highest efficiency. The sound level might deviate significantly, depending on the working point. For details, see "Pump characteristic" in the enclosed documentation.

10.2 Maintenance intervals¹

Model	Interval	Maintenance task	Chapter
All models with sealing/ quenching liquid option	Daily	Check sealing or quenching liquid	See Section 9.3 "Check the sealing or quenching fluid line (optional)", page 15
KF1, KF2, KF3	5000 h	Lubricate shaft bearing	See Section 9.5.2 "Model KF", page 15
All	As required	Replace shaft seal	See Section 9.7 "Replace shaft seal", page 16
All	As required	Change motor	See Section 9.6 "Change motor", page 16
FPC...V	As required	Change shaft	See Section 9.11 "Model FPC...V: Mount and align the pump shaft", page 22
All	According to manufacturer specifications	Lubricating motor bearing	See Section 9.4 "Lubricate motor bearing", page 15

Table 10 Maintenance intervals

¹For maintenance intervals of the motor, see motor operating manual.

10.3 Malfunction table

Problem	Possible cause	Remedy
Pump not conveying or irregular flow rate	Suction line closed / clogged	Open / clean suction line
	Suction filter dirty	Clean suction filter
	Pressure side shut-off valve closed	Open pressure line
	Pump not completely filled with liquid	Install pipeline system so that the pump casing is filled with liquid, even when at standstill
	Pump with geodetic suction height ¹ ; liquid level drops during standstill	Install foot valve in suction line
	Suction line leaking (sucking in air)	Seal suction line
	Foot valve blocked / dirty	Clean / repair foot valve
	Suction height too great	Position pump lower Reduce suction height
	Air lock in suction line	Always lay suction lines rising to the pump
	Too much air or gas in conveying medium	Install vent valve
	Air entering through shaft seal	Check shaft seal installation Replace elastomers
	Cavitation at impeller inlet, excessive resistance in suction line, suction height too great NPSH value of unit not adjusted to pump	Optimise suction line, increase suction head, reduce medium temperature, contact <i>Fristam</i>
	Flow rate too high	Pressure side valve opened too far
Diameter of pressure line too large		Decrease nominal pipe diameter Insert orifice plate
Impeller diameter too large		Reduce outer impeller diameter Reduce speed with frequency inverter Contact <i>Fristam</i>
Flow rate too low, static head too low	Pump too small	Contact <i>Fristam</i>
	Impeller diameter is too small	Contact <i>Fristam</i> Replace impeller
	Incorrect direction of motor rotation	Exchange connections in motor terminal box
	Rotation speed too low (incorrect voltage)	Correct power supply according to motor type plate
	Nominal diameters of pipelines too small	Install pipes with larger diameter
	Pipeline resistance in suction and/or pressure line too high	Optimise pipeline system, reduce number of bends and valves Contact <i>Fristam</i>
	Pipes clogged	Clean pipes
	Foreign objects/deposits in impeller	Remove and clean impeller
	Impeller incorrectly installed	Check impeller clearance and re-adjust
	Density of pumping medium too high Viscosity of pumping medium too high	Contact <i>Fristam</i>
Metallic noise	Foreign object in pump interior	Dismantle pump, examine and repair
	Impeller resp. rotor starts up	Check direction of rotation, readjust impeller clearance, exchange retaining washer, tighten rotor with torque wrench
	Pump/shaft seal runs dry	Add pumping medium immediately, open suction valve

Table 11 Troubleshooting

Problem	Possible cause	Remedy
Flow noises	Pump operated outside specified load range (overload)	Adjust working point to specifications
	Flow loss in suction line too high	Increase nominal width, reduce pipeline lengths, prevent gas emission
	Cavitation	Check conditions for NPSH evaluation, contact <i>Fristam</i>
Vibrations	Suction and pressure lines put inadmissible strain on the pump	Pipes must be supported so that they do not place a load on the pump; install vibration dampers if necessary, avoid pressure surges at the pump
Excessive heating of shaft bearing	Damage to bearing	Replace bearing
Current consumption of motor too high	Flow rate too high	Close the valve in the pressure line Reduce speed with frequency inverter
	Impeller diameter too large	Reduce impeller diameter Contact <i>Fristam</i>
	Viscosity and/or density of the pumping medium too high	Contact <i>Fristam</i>
	Serious damage to shaft bearing, shaft deformed	Dismantle, inspection, and have it repaired by <i>Fristam</i> .
Leakage at shaft seal	Rotor lose	Dismantle impeller, inspect shaft shoulder Check shaft seals, mount rotor, tighten with necessary tightening torque Possibly exchange of parts. Exchange retaining washer
	Mechanical damage / wear to shaft seal or rotary shaft seal	Replace shaft seal, including elastomers, change seal material Contact <i>Fristam</i>
	Shaft seal running dry, suction height too great, pumping medium temperature too high	Increase pump inlet pressure, reduce suction height, install double shaft seal, contact <i>Fristam</i>
	Sealing water pressure too high	Adjust with restrictor valve
	Sealing water pressure too low	Replace radial shaft seal
	Water tube blocked, (causing damage to radial shaft seal) Sealing water dirty	Clean water tube Adjust water feed and discharge, use water of drinking water quality at max. 70°C
	pumping Medium temperature too high	Contact <i>Fristam</i> Convert to double shaft seal

Table 11 Troubleshooting

¹The geodetic suction height is the vertical distance between the surface of the suction side liquid level and the center of the impeller.

10.4 Numbers in sectional drawings

The general list of numbers refers to the enclosed "sectional drawings". The parts numbers are in accordance with DIN 24250.

Part no.	Designation
101	Pump casing
108	Stage casing
160	Cover
160-1	Rotor cover
13-1	Back casing panel
13-2	Casing insert
130	Casing part
132	Spacer
135	Wearing bush
154	Intermediate wall
156	Outlet side
18-1	Spherical cap bearing
18-2	Vibration absorber
182	Base
21-1	Synchronizing shaft
213	Drive shaft
23-1	Displacer
23-4	Rotor
26-1	Bracket for mech. seal chamber
230	Impeller
32-1	Angular ball bearing
32-2	Cylindrical roller bearing
32-3	Grooved ball bearing
32-4	Tapered roller bearing
321	Radial ball bearing
322	Radial roller bearing
325	Needle bearing
330	Bearing holder
331	Bearing block
341	Drive lantern
344	Bearing holder lantern
350	Bearing housing
360	Bearing cover
40-4	Half-length taper grooved pin
400	Flat seal
410	Profile seal
411	Sealing ring
412	O-ring
421	Radial gasket
422	Felt ring
423	Labyrinth ring
433	Mechanical seal
45-1	Support ring
451	Stuffing box housing
454	Gland seal ring
47-1	Spring with washer
47-2	Mechanical seal chamber
47-3	Wedge seal
47-5	Ring nut
471	Sealing cover
472	Rotating seal ring
474	Thrust collar
475	Stationary seal ring
476	Counter ring holder

Part no.	Designation
477	Spring for mechanical seal
478	Spring, right
479	Spring, left
481	Bellows
482	Bellows support
484	Spring washer
485	Seal driver
500	Ring
50-1	Spring washer
50-2	V -Ring
50-3.60	Adjusting ring
504	Spacer ring
520	Sleeve
523	Shaft sleeve
524	Shaft protective sleeve
525	Spacer sleeve
54-1	High-pressure cover bushing
54-2	Bushing
54-3	Stationary bushing
540	Bushing
543	Spacer bushing
55-1	Serrated washer
550	Washer
551	Spacer washer
554	Washer
561	Grooved pin
56-1	Roll pin
56-2	Grooved drive stud
560	Pin
562	Cylindrical pin
59-2	Dished type lock washer
59-3	Shrink ring
59-4	Lantern
59-5	Membrane
642	Oil level sight glass
680	Enclosure
68-1	Sheet metal strip
68-2	Foam strip
68-3	Holder for enclosure
68-4	Orifice plate
68-5	CF guard plate
681	Coupling guard
701	Bypass line
702	Return line
710	Pipe
71-1	Connection pipe
715	Hose pipe
722	Flange adapter
723	Flange
724	Blind flange
733	Pipe clamp
751	Valve housing
755	Valve spindle
756	Valve spring

Part no.	Designation
759	Valve disc
800	Motor
801	Flange motor
87-1	Gearbox
87-2	Gearbox cover
87-3	Gearbox cap
87-4	Gear foot
839	Contact
872	Gearwheel
89-1	Filler piece
89-2	Support for adjustable leg
89-3	Motor base
89-4	Handle
89-5	Protective cap
89-6	Wheel
89-8	Flat steel
89-9	Motor carrier
89-10	Motor carrier
89-11	Spherical cap base support
892	Foot plate
894	Bracket
897	Guide piece
90-1	Stud bolt
90-3	Taper pin
90-4	Half-length taper grooved pin
90-5	Eye bolt
900	Screw
901	Hexagon head screw
902	Stud
903	Threaded plug
904	Threaded pin
906	Impeller bolt
909	Adjusting screw
91-1	Slotted cheese head screw
913	Vent screw
914	Hexagon socket screw
92-1	Long star handle nut
92-2	Short star handle nut
92-3	Cap nut
92-4	Rotor nut
92-5	Forcing screw
92-6	Rotor fixture
92-7	Nut with collar
920	Hexagon nut
921	Shaft nut
922	Impeller nut
923	Bearing nut
93-1	Snap ring
930	Retainer
931	Retaining washer
932	Snap ring
940	Key
941	Disk spring
950	Spring

11 Appendix 2 – Mounting instructions (Option)

11.1 Safety instructions

These mounting instructions are exclusively intended for expert personnel.

11.2 Application

These mounting instructions apply for pumps that were delivered without motor (optional) and pre-assembled.

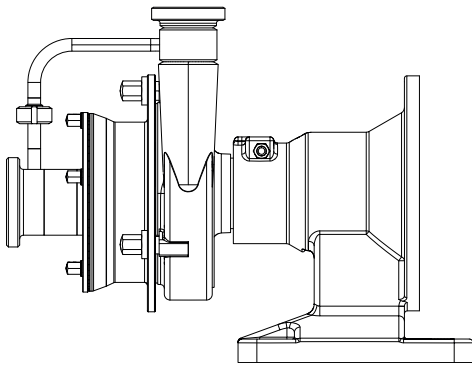

Fig. 32 Incomplete machine: Pump without motor, exemplary of model KF

The following details in the “original operation manual” for complete machines are invalid in this case:

- Chapter 10.5 “EC Declaration of Conformity”, page 28,
- Chapter 10.1.2 “Noise emission”, page 23
- Chapter 2.4.4 “Type plate”, page 7.

11.3 Type plate

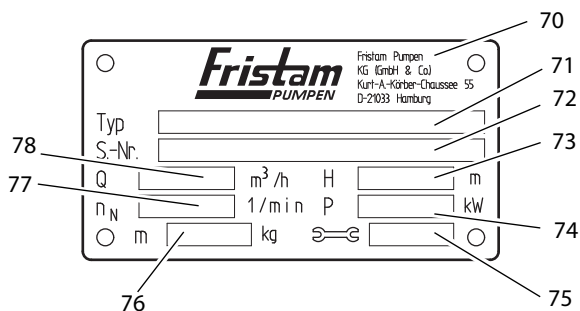

Fig. 33 Type plate for pumps without drive

70	Manufacturer
71	Type: Pump series, size, design, version
72	S. no.: Serial number of the pump

73	H: Conveying height [m]; without drive: no details
74	P: Motor output [kW]; without drive: no details
75	Year of manufacture
76	m: Weight (pump without drive) [kg]
77	n_N : Rated speed [1/min]; without drive: no details
78	Q: Flow rate [m ³ /h]; without drive: no details

11.4 Transport without motor

All transport tasks must be carried out by trained personnel.

The pump can be transported by forklift truck or by crane.

Always transport the pump in its installation position.

11.4.1 Safety instructions

Falling or unsecured parts

Severe crushing.

- ▶ Always wear safety gloves during all transport work.

Incorrect transport position of pump

Escape of caustic, toxic or contaminating liquids. Damage to persons and/or property through contamination.

- ▶ Always transport pump in installation position.

Open, unsealed pipe connections

Damage to property due to contamination, impacts or moisture in the pump.

- ▶ Only remove pipe connections directly before connection to the pipes.

11.4.2 Transportation with forklift truck

⚠ WARNING

Unsecured parts

Severe injury due to crushing, crushing of limbs, damage to property.

- ▶ Prior to transport, secure the pump against falling. Secure it to the pallet, using securing straps or screws.

Preparation

Ensure that the pump is properly secured on the pallet. Example with straps Fig. 34 “Transport with lifting equipment”, page 30.

Procedure

1. Pick up the pallet with the forks of the forklift truck.
2. Carefully transport the pallet to the intended location and lower it to the ground.

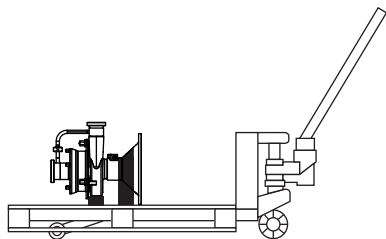

Fig. 34 Transport with lifting equipment

11.4.3 Transport with crane

WARNING

Falling parts

Death due to crushing, crushing of limbs, damage to property.

- ▶ Only use transport and hoists designed for the total weight of the pump.

For details about the weight of the pump, see type plate of the pump and at "Order-related documents" in the enclosed documents.

- ▶ Do not leave the pump in an suspended position for longer than is necessary.
- ▶ Ensure that there are no persons standing below the suspended the pump.

WARNING

Swinging parts

Risk of crushing and serious injury.

- ▶ While transporting the pump, start and stop the crane without jerking.
- ▶ Ensure that there are no persons in the danger zone of the pump.

Auxiliary equipment

- Hoists: tested round slings in accordance with DIN EN1492-1 and 1492-2.
- Eye bolt and suitable lifting devices for eye bolt

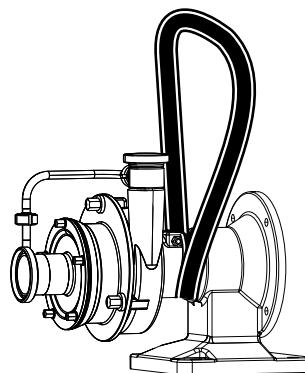

Fig. 35 Transport by crane

Preparation

- ▶ Remove transport safeguards.

KF to be transported with round sling:

Procedure

1. Wrap round sling two times around the lantern neck (see Fig. 35 "Transport by crane", page 30).
2. Lead other end of round sling to crane hook and hook in.
3. Position the center of gravity so that the pump is lifted in a horizontal position.
4. Lift the pump.

11.5 Installation site

For the general conditions regarding the installation site, refer to the operation manual Chapter 6.2 "Installation site", page 11.

11.6 Mount pump

11.6.1 Model KF

Requirement (customer-side)

- Suitable motor

ATTENTION

Incorrect layout of motor

Destruction of the pump

- ▶ Only use motors that match the pump characteristics. Contact *Fristam* if you have questions.

Procedure

1. Insert the key into the motor groove.
2. Slide motor shaft into the compact bearing support.
3. Secure the motor to the compact bearing support. Tighten screws crosswise.

Архангельск (8182)63-90-72
Астана (7172)727-132
Астрахань (8512)99-46-04
Барнаул (3852)73-04-60
Белгород (4722)40-23-64
Брянск (4832)59-03-52
Владивосток (423)249-28-31
Волгоград (844)278-03-48
Вологда (8172)26-41-59
Воронеж (473)204-51-73
Екатеринбург (343)384-55-89
Иваново (4932)77-34-06

Ижевск (3412)26-03-58
Иркутск (395)279-98-46
Казань (843)206-01-48
Калининград (4012)72-03-81
Калуга (4842)92-23-67
Кемерово (3842)65-04-62
Киров (8332)68-02-04
Краснодар (861)203-40-90
Красноярск (391)204-63-61
Курск (4712)77-13-04
Липецк (4742)52-20-81
Киргизия (996)312-96-26-47

Магнитогорск (3519)55-03-13
Москва (495)268-04-70
Мурманск (8152)59-64-93
Набережные Челны (8552)20-53-41
Нижегород (831)429-08-12
Новокузнецк (3843)20-46-81
Новосибирск (383)227-86-73
Омск (3812)21-46-40
Орел (4862)44-53-42
Оренбург (3532)37-68-04
Пенза (8412)22-31-16
Казахстан (772)734-952-31

Пермь (342)205-81-47
Ростов-на-Дону (863)308-18-15
Рязань (4912)46-61-64
Самара (846)206-03-16
Санкт-Петербург (812)309-46-40
Саратов (845)249-38-78
Севастополь (8692)22-31-93
Симферополь (3652)67-13-56
Смоленск (4812)29-41-54
Сочи (862)225-72-31
Ставрополь (8652)20-65-13
Таджикистан (992)427-82-92-69

Сургут (3462)77-98-35
Тверь (4822)63-31-35
Томск (3822)98-41-53
Тула (4872)74-02-29
Тюмень (3452)66-21-18
Ульяновск (8422)24-23-59
Уфа (347)229-48-12
Хабаровск (4212)92-98-04
Челябинск (351)202-03-61
Череповец (8202)49-02-64
Ярославль (4852)69-52-93